

# **STIHL BR 106**

**Instruction Manual  
Owner's Manual**

**Assembling  
Safety Precautions  
Operating Instructions  
Maintenance**



**Warning:**  
Always follow safety precautions in  
Owner's Manual – improper use  
can cause serious injury!

## STIHL BR 106

This manual contains operating and safety instructions for the **STIHL BR 106 blower**.

Pay special attention to the safety precautions outlined on pages 4 to 10. Allow only persons who understand this manual to operate your blower.

To receive maximum performance and satisfaction from your STIHL unit, it is important that you read and understand the maintenance and safety precautions before using your unit. Contact your STIHL dealer or the STIHL distributor for your area if you do not understand any of the instructions in this manual.

### Warning!

As with any other power tools, certain special safety precautions must be observed to reduce the risk of personal injury. Careless or improper use may cause serious or even fatal injury.

STIHL's philosophy is to continually improve all of its products. As a result, engineering changes and improvements are made from time-to-time. If the operating characteristics or the appearance of your unit differs from those described in this manual, please contact your STIHL dealer for information and assistance.

### Owner's Manual

#### Contents

Controls BR 106	2
Safety Precautions	4
– the operator	4
– the blower	5
– the use of the blower	6
– Maintenance, repair and storing	10
Assembly of Blower	11
Fuel	13
General Notes on Operation	14
Control Handle	15
Starting	16
Carburetor	19
Air Filter	20
Rewind Starter	21
Maintenance Chart	24
Specifications	25

## Controls BR 106

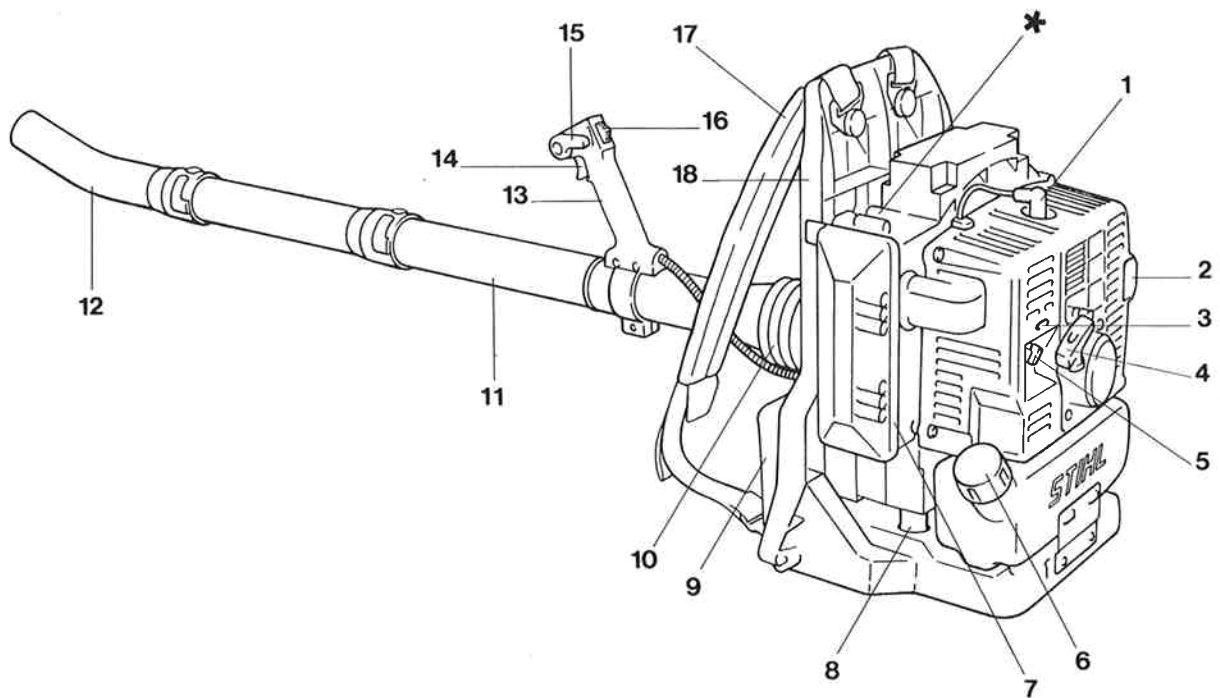

- |                                |                     |
|--------------------------------|---------------------|
| 1 Spark plug terminal          | 11 Blower tube      |
| 2 Muffler                      | 12 Nozzle           |
| 3 Carburetor adjustment screws | 13 Control handle   |
| 4 Starter grip                 | 14 Throttle trigger |
| 5 Choke lever                  | 15 Setting lever    |
| 6 Fuel filler cap              | 16 Stop switch      |
| 7 Air filter                   | 17 Carrying harness |
| 8 Rubber buffers               | 18 Back plate       |
| 9 Back rest pad                |                     |
| 10 Pleated hose                | * Serial number     |

## Definitions

1. **Spark plug terminal.** Connects the spark plug to the ignition wire.
2. **Muffler.** Attenuates exhaust noises and diverts exhaust gases away from operator.
3. **Carburetor adjustment screws.** For tuning carburetor.
4. **Starter grip.** The grip of the pull starter, which is the device to start the engine.
5. **Choke lever.** Eases engine starting by enriching mixture.
6. **Fuel filler cap.** For closing the fuel tank.
7. **Air filter cover.** Covers the air filter element.
8. **Rubber buffers.** Elements designed to reduce the transmission of vibrations created by the engine to the operators back.
9. **Back rest pad.** Increases carrying comfort.
10. **Pleated hose.** For spraying, dusting or spreading in the desired direction.
11. **Blower tube.** Directs spray or airstream.
12. **Nozzle.** Aims and widens the spray or airstream.
13. **Control handle.** Handle on the flexible hose to hold and direct the tube in the required direction.
14. **Throttle trigger.** Controls the speed of the engine.
15. **Setting lever.** Sets the throttle to various positions.
16. **Stop switch.** Stops engine.
17. **Carrying harness.** For carrying the unit.
18. **Back plate.** Helps protect the back of the user.

## Safety Precautions

The use of any blower may be dangerous. It is important that you read, fully understand and observe the following safety precautions and warnings. Read the owner's manual and the safety instructions periodically.

### Warning!

Careless or improper use of the machine may cause serious injury. Have your STIHL Dealer show you how to operate your blower. Observe all applicable local safety regulations, standards and ordinances.

### Warning!

Minors should never be allowed to use a blower. Bystanders, especially children and animals should not be allowed in the area where a machine is in use (ill. 1). Never let the unit run unattended.

Do not lend or rent your machine without the owner's manual. Be sure that anyone using your unit understands the information contained in this manual.

See the appropriate section of your owner's manual for a description of the controls and function of the parts of your machine.

### Safe use of a blower involves

1. the operator
  2. the blower
  3. the use of the blower
- 4



## THE OPERATOR

### Physical Condition

You must be in good physical and mental health and not under the influence of any substance (drugs, alcohol, etc.) which might impair vision, dexterity or judgment. Do not operate a blower when you are fatigued (ill. 2). Be alert – If you get tired while operating your machine, take a break. Tiredness may result in loss of control. Working with any blower can be strenuous. If you have any condition that might be aggravated by strenuous work, check with your doctor before operating the machine.



### Proper Clothing

#### Warning!

Blower operation can cause serious injury to eyes, ears and person.

Even though the discharge is directed away from the operator, ricochets and bounce backs can occur during blower operations.

Therefore, to reduce the risk of injury to your eyes never operate a blower unless wearing goggles or properly fitted safety glasses with adequate top and side protection

complying with ANSI Z 8.71 (or your applicable national standard).

To protect your face STIHL recommends that you also wear a face shield or face screen over your goggles or safety glasses.

Clothing must be sturdy and snug-fitting, but allow complete freedom of movement. Avoid loose-fitting jackets, flared or cuffed pants, scarfs, unconfined long hair or anything that could be drawn into the air intake. Wear overalls or long pants to protect your legs (ill. 3). Do not wear shorts. Use gloves when working with the blower.

Good footing is most important. Wear sturdy shoes with nonslip soles.

#### Warning!

To reduce the risk of injury associated with the inhalation of dust, use a face filter mask when using your blower in dusty conditions.

Blower noise may damage your hearing. Wear sound barriers (ear plugs or ear muffers) to protect your hearing. Continual and regular users should have their hearing checked regularly.

### THE BLOWER

For illustrations and definitions of the blower parts see the chapter on "BR 106 Controls"!

#### Warning!

Never modify a blower in any way. Only attachments supplied by STIHL or expressly approved by STIHL for use with the specific STIHL blower models are authorized.



## THE USE OF THE BLOWER

### Transport

Always turn off the engine before taking the machine off your back and putting it down. When transporting your unit in a vehicle, properly secure it to prevent turnover, fuel spillage and damage to the machine.

### Preparation for the use

Before starting work, always inspect the rubber buffers which connect the engine to the pack frame. If the buffers are worn to damaged, they should be replaced by your STIHL dealer. Failure of one or more buffers may cause the engine or fuel tank to hit or rub against other parts, and may lead to serious injury from increased vibrations or from fire as the result of fuel leakage.

Adjust carrying harness to suit your size before starting work.

### Fueling

Your STIHL unit uses an oil-gasoline mixture for fuel (see the chapter on "Fuel" of your owner's manual).

### Warning!

Gasoline is an extremely flammable fuel. Use extreme caution when handling gasoline or fuel mix. Do not smoke or bring any fire or flame near the fuel (ill. 4).

### Fueling Instruction

Fuel your machine in well-ventilated areas, outdoors only. Always shutt off the engine and allow it to cool before refueling. Relieve fuel tank pressure by loosening fuel cap slowly. Never remove fuel filler cap while engine is running.

Select bare ground for fueling and move at least 10 feet (3 m) from the fueling spot before starting the engine.

Wipe off any spilled fuel before starting your blower and check for leakage.

Always tighten fuel filler cap securely after fueling.

### Warning!

To reduce the risk of serious injury from burns, never attempt to refuel the unit until it has been completely removed from the operator.

Check for fuel leakage while refueling and during operation. If fuel or oil leakage is found, do not start or run the engine until leak is fixed and spilled fuel has been wiped away. Take care not to get fuel on your clothing. If this happens, change your clothing immediately.

Always store gasoline in approved container.

### Starting

You should always inspect your unit before starting it. Make sure the controls and safety devices are working properly.

**Warning!**

Your BR 106 is generally a one-person machine. To reduce the risk of eye or other injury from thrown objects, insure that bystanders are at least 30 feet (10 m) away during use.

The assistance of another person may be needed in placing the unit on your back after starting. In order to reduce the risk of injury to the assistant from thrown objects, the engine should be kept at idle speed during this brief period, and your assistant should not stand in the area of the outlet nozzle or exhaust. Otherwise, the unit should be started and operated without assistance.

For specific starting instructions, see the appropriate section of your manual.

Place the machine on firm ground or other solid surface in an open area. Maintain a good balance and secure footing.

**Warning!**

When you pull the starter grip, don't wrap the starter rope around your hand. Do not allow the grip to snap back, but guide the starter rope slowly back to permit the rope to re-wind properly. Failure to follow this procedure may result in injury to hand or fingers and may damage the starter mechanism.

**Working instructions and important adjustments**

**Warning!**

Never operate your machine if it is damaged, improperly adjusted or not completely and securely assembled. Start and operate your unit outdoors in a ventilated area.



Breathing exhaust fumes can cause serious or fatal injury.

Keep the space behind the blower engine clear at all times to allow for the escape of hot and toxic exhaust fumes. Operate your machine under good visibility and daylight conditions only. Work carefully.

**Working Conditions**

When working with the blower always wear it on your back using the carrying harness.

Wrap your fingers tightly around the handle, keeping the control handle cradled between your thumb and forefinger. Keep your hand in this position to have your machine under control at all times. Make sure your control handle and grip is in good condition and free of moisture, pitch, oil or grease.

**Warning!**

To reduce the risk of injury, do not blow in anyone's direction, as the unit can blow small objects at high speed (ill. 5).



Never insert any foreign object into the air intake of the machine. It will damage the fan wheel or even cause serious injuries to the operator.

Do not place the blower on the ground when operating at high speed, because small objects such as sand, grass, dust, etc. may be pulled into the air intake and damage the fan wheel.

Pay attention to the direction of the wind, i.e., do not work against the wind. Do not direct air blast towards bystanders.

Do not walk backward while operating the machine.

In an emergency, you may slip out of the harness and throw off the machine quickly by first releasing the lap belt – on machines that are so equipped – and then lifting the tabs of the two sliding harness adjusters to slacken the shoulder straps. Try this procedure a number of times before using the machine in order to become accustomed to it.



Gravel paths and walks, gravel-covered flat roofs, ditches etc. can be slow-swept quickly.

Other applications are blowing out pipes, drains, gutters and your carport.

### **Operating Instructions**

The blower may be used only for the operations described in your manual.

### **Use of blower**

The STIHL blower can be used for clearing leaves and grass clippings from gardens and driveways and can also be used for blowsweeping paper, trash, dust, light snow etc. from large areas, sport stadiums or parks (ill. 6).

### **Maintenance, Repair and Storing**

Use only STIHL replacement parts for maintenance and repair. Use of parts manufactured by others may cause serious or fatal injury.

Follow the maintenance and repair instructions in the appropriate section of your owner's manual.

#### **Warning!**

Always stop the engine before doing any maintenance or repair work or cleaning the unit. Do not attempt any maintenance or repair work not described in your owner's manual. Have such work performed at your STIHL service shop only.

To reduce the risk of fire and serious burn injuries, check fuel filler cap for leaks at regular intervals and replace worn or damaged ignition leads immediately.

#### **Warning!**

A worn or damaged muffler is a fire hazard and may also cause loss of hearing. The unit must not be operated if the muffler is not functioning properly or has been removed. Use the spark arresting muffler supplied with the unit. Never touch a hot muffler or burn will result.

Tighten all nuts, bolts and screws except the carburetor adjustment screws after each use.

Use the specified spark plug. Keep spark plugs and wire connections tight and clean.

The spark plug electrode gap should be checked with a feeler gauge at least every 50 operating hours and reset if necessary. Fit a new spark plug if the electrodes are badly pitted.

Store unit in a high or locked place, away from children, and empty the fuel tank before storing for longer than a few days.

## Assembly of Unit

The unit is partly disassembled for ease of shipment and must be completely assembled before it is used for the first time.

The tools on the underside of the unit (1 combination wrench and 1 carburetor screwdriver) should be used for the assembly work.

### Mounting the elbow

- Line up the stops on the elbow (1) and fan housing stub (2).
- Push the elbow (1) into the stub (2) as far as it will go.
- Fit a nut (3) into each of the molded hexagon seats on the stub.
- Insert a screw (4) into each nut from the other side and tighten moderately (it must still be possible to turn the elbow).

**Important:** The throttle cable with integrated stop switch wire is already connected to the control handle and the engine and must not be kinked during assembly.

- Attach throttle cable with the retainer (5) to the pleated hose.

### Mounting the blower tube

- Push the blower tube (6) into the pleated hose (7).
- Push blower tube (8) onto the end of tube (6) and rotate it clockwise until the bayonet catch engages.
- Push the nozzle (9) onto the end of tube (9) and rotate it clockwise until the bayonet catch engages.

Top: Elbow fitted to fan housing  
Bottom: Complete blower tube with nozzle

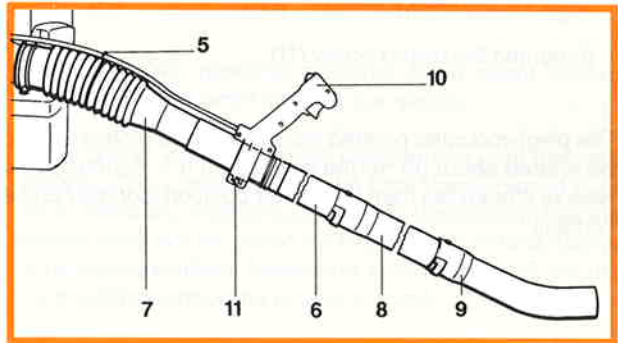
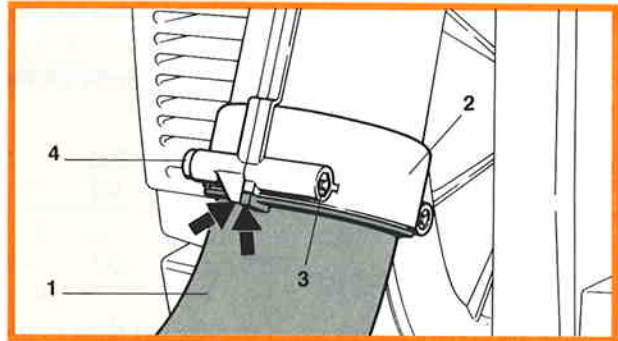

- Rotate the pleated hose (7) to the left (counterclockwise) as far as the stop and leave it in that position until you have completed the following adjustments.
- Rotate the control handle (10) to the left (counterclockwise) until it is horizontal.
- Rotate the complete blower tube to the left (counterclockwise) until the diffuser nozzle points in the same direction as the control handle.
- Tighten the clamp screw (11). (Observe instructions in chapter “Adjusting the control handle”)

### Adjusting the control handle

You can adjust the position of the control handle on the pleated hose to suit your reach.

Carry out the adjustment as follows:

- Put the unit on your back.
- Release the clamp screw (11).
- Slide the control handle along the pleated hose to the most comfortable position.
- Retighten the clamp screw (11).

The pivot-mounted pleated hose allows the blower tube to be rotated about 90° to the left or right (i.e. counterclockwise or clockwise) from the center position (control handle vertical).

### Adjusting the harness straps

The harness straps are attached to the backplate and have sliding adjusters for adjustment to any required length.

Pull the ends of the straps downward to tighten the backplate against your back. Lift the tabs of the two sliding adjusters to slacken the harness straps.

Adjust the straps so that the backplate is held firmly and securely against your back.

Top: Range of adjustment of control handle  
Center: Range of rotation of tube  
Bottom: Pulling ends of straps downward (left)  
Lifting tabs of strap adjusters (right)

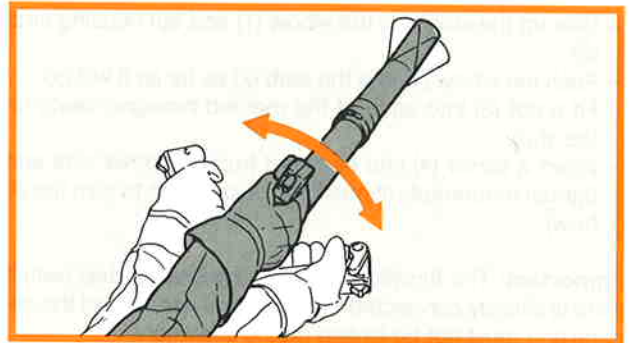
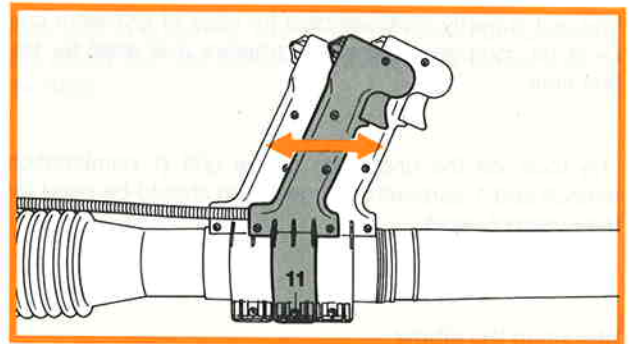

## Fuel



Fuel filler cap removed

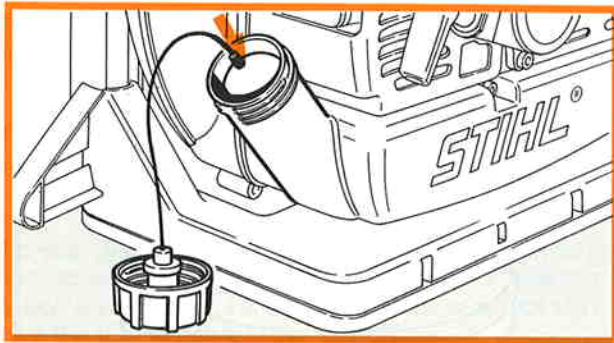

Your two-stroke engine runs on a mixture of gasoline and two-stroke, air-cooled engine oil.

Use regular branded gasoline, leaded or unleaded, with a minimum octane number of 90 ROZ (U.S.A./Canada: pump octane min. 87!). If the octane number of the regular grade gasoline in your area is lower, it may cause preignition ("pinging") which is accompanied by a rise in engine temperature. This increases the risk of piston seizure and damage to the engine.

The chemical composition of the fuel is also important. Some fuel constituents not only detrimentally affect elastomers (carburetor diaphragms, oil seals, fuel lines etc.), but magnesium castings as well. This could cause running problems or even damage the fuel tank. For this reason it is essential that you use only name branded fuels!

Use only STIHL two-stroke engine oil or equivalent branded two-stroke air-cooled engine oils for mixing. We recommend STIHL 50:1/40:1 two-stroke engine oil since it is specially formulated for use in STIHL engines. The mix ratio with STIHL oil is 50:1/40:1 (50/40 parts gasoline to 1 part oil), or 25:1 (25 parts gasoline to 1 part oil) with other branded two-stroke air-cooled engine oils.

Do not use BIA or TCW (two-stroke water cooled) mix oils!

Gasoline	STIHL-oil 50:1		STIHL-oil 40:1		Other branded two-stroke eng. oils (25:1)		
	U.S. gal	U.S. oz	U.S. Lit.	U.S. oz	U.S. Lit.	U.S. oz	
1.0	—	0.020	—	0.025	—	0.04	—
—	1.0	—	2.56	—	3.2	—	5.12
5.0	—	0.100	—	0.125	—	0.20	—
—	2.5	—	6.4	—	8.0	—	12.8
10	—	0.200	—	0.250	—	0.40	—
—	5.0	—	12.8	—	16.0	—	25.6

Take care when handling gasoline. Avoid direct contact with the skin and avoid inhaling fuel vapour.

When mixing, pour oil into the canister first, and then add gasoline. The canister should be kept tightly closed in order to avoid any moisture getting into the mixture. The fuel mixture must not be stored for long periods of time. Do not store large quantities. Always mix sufficient fuel for about a few month's work or the project in hand.

Always thoroughly shake the mixture in the canister before fueling your machine. The fuel tank may be under pressure. Remove cap slowly!

Always tighten fuel filler cap securely after fueling.

The fuel tank and the canister in which fuel mix is stored should be cleaned from time to time. Before storing your machine for a long period, drain and clean the fuel tank and run engine until carburetor is dry.

Change the filter element in the fuel pick up body every year.

## General Notes on Operation

### Starting for first time

A factory new machine must not be run at full throttle for the first three tank fillings.

As all the moving parts have to bed in during the break-in period, the frictional resistances in the engine are greater during this period. For this reason the engine only develops its maximum power after about 5 to 15 tank fillings.

### During operation

The machine must not be put down on the ground with the engine running because the fan would otherwise suck in leaves and coarse dirt and block the intake openings. This also reduces the flow of cooling air to the engine which could then overheat, causing piston seizure and further serious damage to associated engine components.

After a long period of working at full load it is advisable not to shut off the engine immediately, but let run for a short while at idling speed. This allows the heat which has built up in the engine during full throttle operation to be dissipated by the flow of cooling air and also protects engine-mounted components (ignition, carburetor) from thermal overload.

### Spark plug

The wrong fuel mixture (too much engine oil in the gasoline), a dirty air filter and unfavorable running conditions (mostly at part throttle etc.) affect the condition of the spark plug. These factors cause deposits to form on the insulator nose which may result in trouble in operation.

Top: Spark plug in good condition  
Bottom: Spark plug fouled because of incorrect running conditions

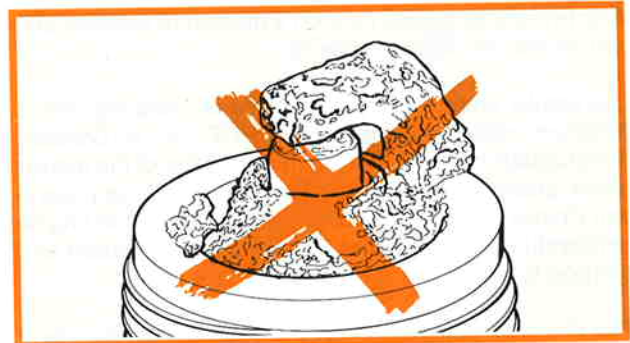
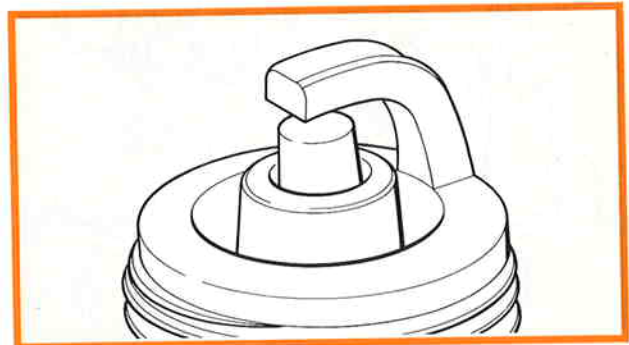

If the engine is down on power, difficult to start or runs poorly at idling speed, check the spark plug before looking any further. If the spark plug is dirty, clean it and check the electrode gap. Readjust if necessary; the correct gap is 0.5 mm (0.02 in). The spark plug should be replaced after about 100 operating hours or earlier if the electrodes are badly eroded.

In order to ensure trouble-free operation it is necessary to rectify the faults which have caused fouling of the spark plug.

## Control Handle

The control handle has two functions. It is used to aim the airstream in the required direction.

The controls (stop switch, throttle trigger and setting lever) are used to select the required engine operating condition.

The stop switch (1) shuts down the engine. The engine is ready to start when the stop switch is in the "I" position. Ignition is interrupted, i.e. the engine stops or will not start, when the stop switch is in the "0" position.

Engine speed can be infinitely varied between idling and maximum speed with the throttle trigger (2).

The setting lever (3) enables any engine speed or throttle position between idling and maximum speed to be selected and held. To do this, swing the setting lever upward to the required position. The setting lever automatically remains in the position selected. The engine runs at idling speed when the setting lever is moved back to its lower end position (see illustration). Always move the setting lever to this end position before shutting down the engine.

Top: Control handle with stop switch, throttle trigger and setting lever  
Bottom: Setting lever in lower end position

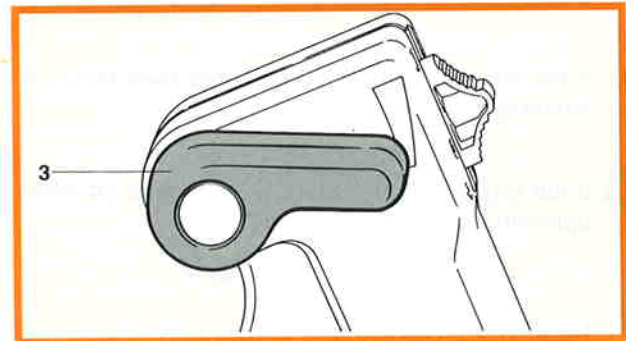
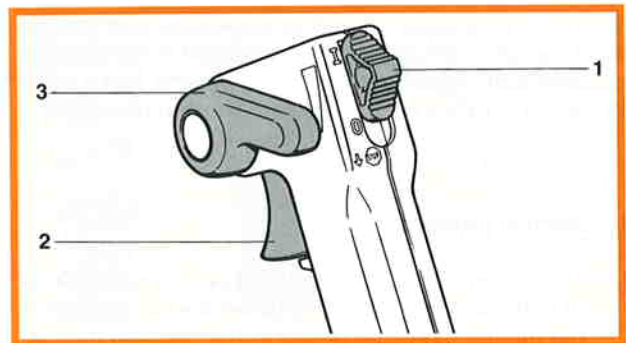



## Starting



Before starting, place the unit on a clear patch of ground. Make sure you have a firm foothold, keep a firm grip on the machine and check that there are no objects which could be sucked in by the fan (between engine and backplate).

### 1. Starting procedure

- 1.1 Slide the stop switch (1) to "I". Move the setting lever (3) to the midway position between the two end stops. The throttle trigger (2) is now in the "starting throttle" position.
- 1.2 If the engine is cold: Turn the choke lever (4) in the direction of the arrow  (choke).
- 1.3 If the engine is warm: Turn the choke lever (4) in the opposite direction to the arrow.

**Note:** This procedure also applies if the engine has been running but is still cold.

Top: Stop switch in "I" position  
Center: Choke lever in "cold start" position  
Bottom: Choke lever in "warm start" position

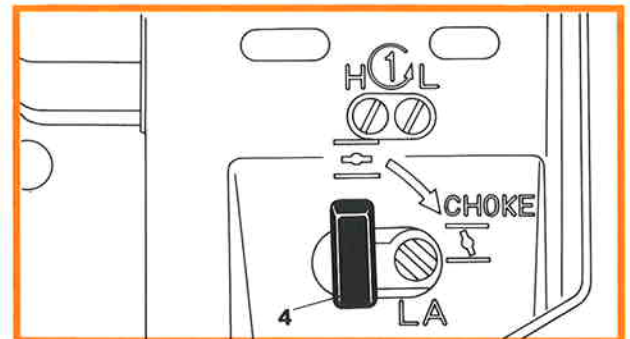
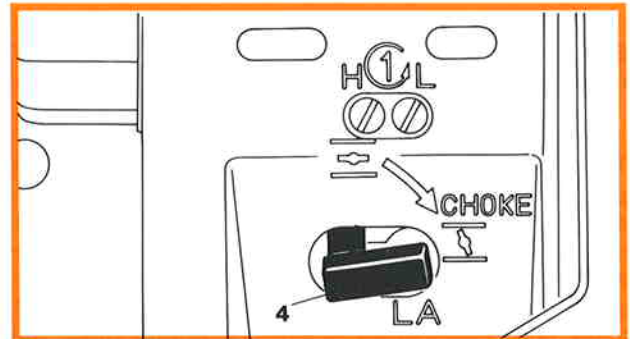
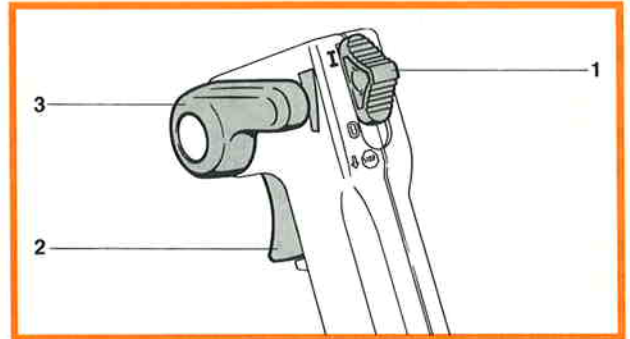

2. To start, hold the top of the machine with your left hand and put one foot on the base plate to prevent it slipping. Pull the starter grip slowly with your right hand until you feel it engage and then give it a brisk strong pull. Do not pull the starter rope out more than about 70 cm (27") as it might otherwise break.

Do not allow the starter rope to snap back. Guide it slowly back into the housing so that it can rewind correctly.

Continue cranking the engine until it begins to fire. Then open the choke immediately (turn choke lever away from arrow) and continue cranking.

3. Once the engine is running, move the setting lever (3) immediately to its lower end position (ill.) so that the engine can settle down to idle speed.

4. To stop the engine, slide the stop switch (1) to "STOP".

Top: Starting  
Center: Setting lever in Lower end position  
Bottom: Stop switch on "STOP"

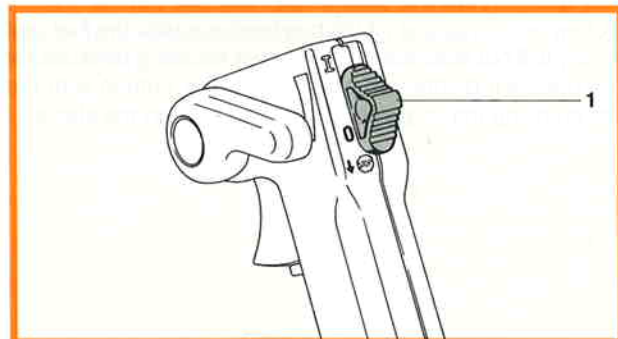
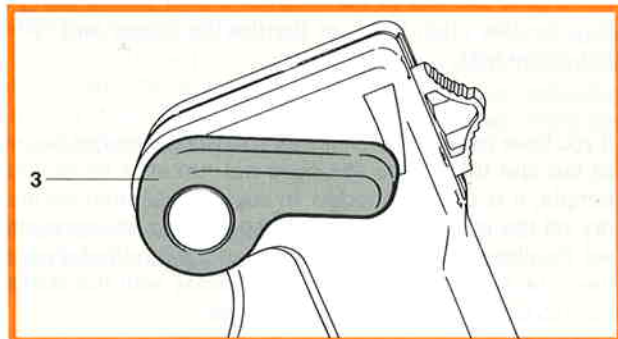
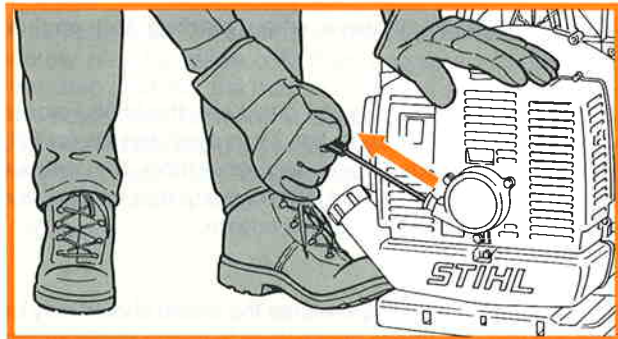

**Other points to observe when starting the engine:**

When starting a cold engine only keep the choke closed until the engine begins to fire. Then open the choke fully even if the engine stops and you have to continue cranking. If the choke is left closed, the combustion chamber will flood and stall the engine.

At very low outside temperatures the choke should only be opened half way (move choke lever to center position) and the engine allowed to warm up for a brief period using a little throttle. Then let go of the throttle trigger and open the choke fully.

If you have opened the choke as soon as the engine began to fire and the engine still does not run after several attempts, it is already flooded. In such a case, remove and dry off the spark plug. With the spark plug still removed, set the slide control to "STOP", open the throttle fully and then crank the engine over several times with the starter rope to clear the combustion chamber.

A new engine or one which has been run until the fuel tank is dry will not start the first time after refueling because the carburetor's diaphragm pump has to be primed with fuel by cranking the engine over several times on the starter.

## Carburetor

- 1 = High speed adjusting screw
- 2 = Low speed adjusting screw
- 3 = Idle speed adjusting screw

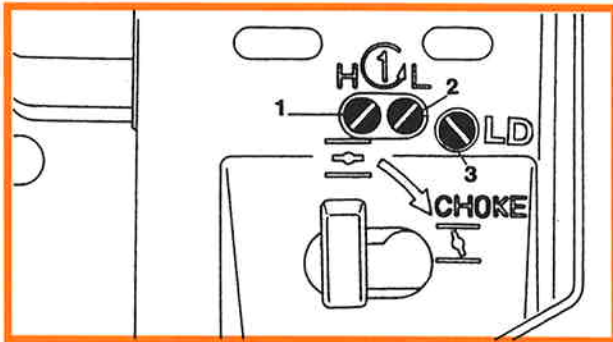

The carburetor is set on the production line for optimum performance at the barometric pressure and climatic conditions prevailing at the factory.

If you use your machine at high altitudes (mountains) or at sea level, it may be necessary to change the carburetor setting slightly. Carry out the correction at the two adjusting screws (1 and 2) as follows: Turn clockwise (leaner) for high altitude operation or counterclockwise (richer) for operation at sea level.

Note that even slight alteration of the adjusting screws has a noticeable effect on the engine's running behavior. Only carry out carburetor adjustments after cleaning the air filter and warming up the engine.

**Caution:** Adjustment of the high speed adjusting screw not only affects the power output but also the maximum engine speed. If the setting is too lean (screw turned too far clockwise), there is a risk of the engine being damaged as a result of inadequate lubrication and overheating.

**Corrections to the setting of the high speed adjusting screw** may be made only if an accurate tachometer is available to check the maximum engine speed. Carry out the adjustment as follows: Using a tachometer, turn the high speed adjusting screw clockwise to obtain maximum engine speed. Then turn the high speed adjusting screw counterclockwise until the engine speed drops about 150 rpm.

### Basic setting

If it is necessary to readjust the carburetor from scratch, first carry out the basic setting to obtain a starting point for fine tuning. To do this, carefully screw the two adjusting screws down onto their seats (clockwise). Then make the following adjustments:

**High speed adjusting screw H:** back off 1 full turn

**Low speed adjusting screw L:** back off 1 full turn

If you have no means of checking the maximum engine speed, do not set the high speed adjusting screw any leaner by turning it beyond the basic setting.

### Notes for adjusting idle speed

#### Engine stops while idling

Turn idle speed adjusting screw (3) clockwise until engine runs and accelerates smoothly

#### Erratic idling behavior; poor acceleration

Idle setting too lean; turn low speed adjusting screw (2) counterclockwise until engine runs and accelerates smoothly.

#### Exhaust smokes at idle speed

Idle speed setting too rich; turn low speed adjusting screw (2) clockwise until engine speed drops. Then turn screw back one quarter turn and check that engine still accelerates smoothly when you open the throttle.

A correction at the low speed adjusting screw usually necessitates a change in the setting of the idle speed adjusting screw (3).

Apart from minor readjustments, you should leave all carburetor setting and repair work to your STIHL dealer. STIHL dealers have trained staff and all the necessary servicing tools and equipment.

## Air Filter

Component parts in correct sequence

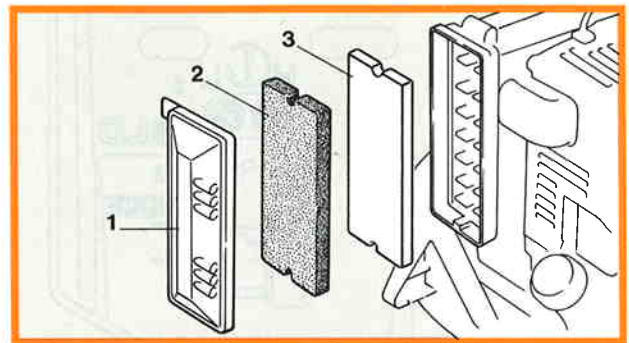

The purpose of an air filter is to prevent the dust and dirt in the intake air from entering the carburetor. It thus helps reduce wear on the engine components to a minimum.

Clogged air filters reduce engine power, increase fuel consumption and make starting more difficult.

**The air filter must therefore be cleaned when engine power begins to drop off.**

Before removing the filter, close the choke (choke lever to "CHOKE") to stop dirt getting into the carburetor. Take off the filter cover (1), the prefilter (2) and foam element (3).

Wash foam filter element in fresh, non-inflammable, cleaning solution. Shake out or blow out felt filter element. Replace if heavily soiled.

Never refit a damaged filter element, always fit a new one.

Install air filter assembly in the reverse sequence. When fitting the filter cover, make sure that the intake openings point toward the starter mechanism.

## Rewind Starter

### Replacing a broken starter rope

If the starter rope is broken there will be no tension on the rewind spring.

First remove the four mounting screws from the starter cover and take it off the crankcase.

Next, remove the screw (1) from the starter post together with the washer (2). The rope rotor (3) can now be pulled off the starter post – this must be done very carefully because the inner loop of the rewind spring (4) has to slip out of the rope rotor. If you feel any resistance, turn the rope rotor slightly clockwise while pulling it.

If the rope rotor (3) is not removed carefully, there is a risk of the spring loop catching on it and jumping out of its seat in the starter cover. If this happens, refit the rewind spring (4) in the starter cover as described under “Replacing a broken rewind spring”.

Remove remaining rope from the rotor (3), thread a new 3.5 mm dia. and 800 mm long (0.14 in dia. × 31.5 in long) starter rope through the rotor and secure it with a simple overhand knot. Pull the rope through so that the knot locates in the recess in the rotor (3). Push the other end of the rope through the hole in the starter cover (from the inside outward) and through the underside of the starter grip (5). Secure rope with a double knot.

Top: Mounting screws  
Center: Removing screw from starter post  
Bottom: Component parts in correct sequence

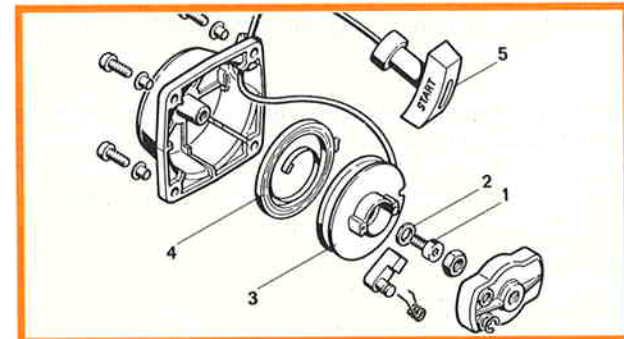
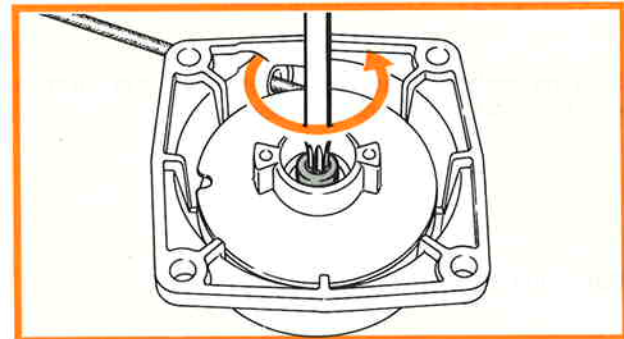
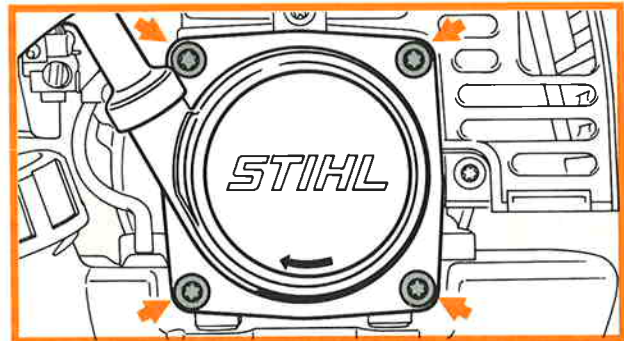

In the case of a new spring or one that has popped out of its seat it is necessary to check and correct the position of the inner spring loop before fitting the rope rotor (3). The position is correct when the loop is approx. 2 mm (0.08 in) away from the starter post.

Coat bore in rope rotor with non-resinous oil. Fit the rotor on the starter post so that the inner spring loop slides into the lug on the rotor. Position starter rope in notch on periphery of rotor at the same time. Check that spring loop has engaged by turning the rope rotor counterclockwise and letting it go – it must spring back.

Refit the washer (2) and screw (1) and tighten down securely. Finish off by tensioning the rewind spring.

### Replacing a broken rewind spring

Remove the rope rotor (4) and use a pair of pliers to take the bits of the broken spring out of the starter cover.

The replacement spring comes ready for installation and is held in position by a wire retainer. It should be lubricated with a few drops of non-resinous oil before installation (e.g. STIHL low temperature lubricant 0781 417 1315).

Top: Rewind spring with inner loop correctly positioned  
Bottom: Fitting the rope rotor

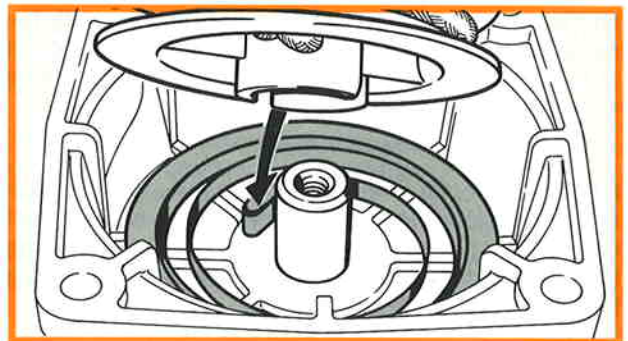
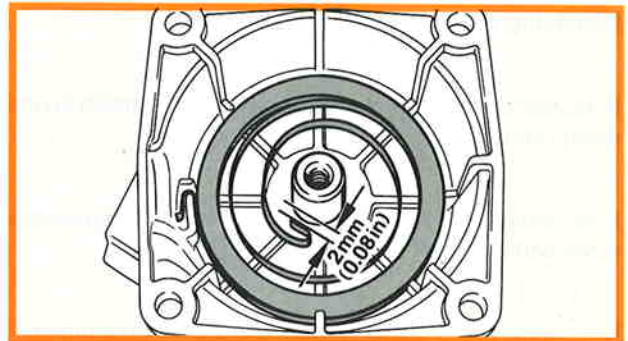

The wire retainer slides off as the rewind spring is positioned in the starter cover. The outer spring loop must be engaged on the lug in the starter cover. If the rewind spring pops out and uncoils during installation, it must be rewound – starting in the middle and working outward – and tensioned to a diameter of 55 mm (approx. 2 1/8"). Hold the rewind spring with pointed nose pliers about 10 mm (3/8") from the end of its outer loop and place it in the starter cover. Then refit the rope rotor (3).

#### Tensioning the rewind spring

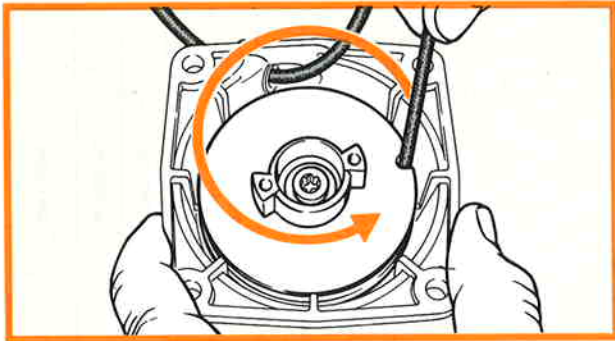

#### Tensioning the rewind spring

Pull the starter rope out as far as it will go. Make a loop in the rope between the rope rotor recess and the starter cover and use it to turn the rope rotor seven times counter-clockwise. Hold the rope rotor steady, straighten out the twisted rope and pull it through the hole in the starter cover and hold firmly.

Release rope very slowly so that it can wind itself onto the rope rotor.

The rewind spring is correctly tensioned when the starter grip sits firmly on the starter cover without hanging to one side. When the starter rope is fully extended it must still be possible to rotate the rope rotor at least another half turn before maximum spring tension is reached. If this is not the case, hold the rope rotor firmly and take off one turn of the rope.

**Do not overtension the rewind spring as this will cause it to break.**



		before starting work	after finishing work or daily	after each refueling stop	weekly	monthly	if faulty	if damaged	as required	see page:
Complete machine	Visual inspection (condition, leaks)	x		x						
	Clean		x							
Control handle (throttle trigger, choke lever, stop switch)	Check operation	x		x						15
Air filter	Clean (Foam filter only)						x			20
	Replace						x	x		20
Filter in fuel tank	Check						x			13
	Replace felt								x	13
Fuel tank	Clean					x				
Carburetor	Check idle adjustment –	x								19
	Readjust idle								x	20
Spark plug	Readjust electrode gap						x			
Air intake slots	Clean				x					
Cylinder fins	Clean					x				
Spark arrestor screen	Inspect									
	Clean or replace									
All accessible screws and nuts (not adjusting screws)	Retighten								x	
Rubber vibration buffers	Visual inspection	x								
	To be replaced only by STIHL dealer						x	x		

Users of the Blower may carry out only the maintenance tasks described in this manual. Other repair work should be performed only by an authorized STIHL servicing dealer.

**Warranty claims following repairs can be accepted only if the repair has been performed by an authorized STIHL Service Shop using original STIHL spare parts.**

Original STIHL parts can be identified by the STIHL part number, the **STIHL** logo and the STIHL parts symbol . The symbol may appear alone on small parts.

## Specifications

### Engine

STIHL single cylinder two-stroke engine  
Displacement: 34,4 cm<sup>3</sup> (2.1 cu. in)  
Bore: 37 mm (1.46 in)  
Stroke: 32 mm (1.26 in)

For US only:  
Bystander noise per ANSI  
B 175.2-1990 69 dB (A)

For Europe only:  
Equivalent sound pressure level L<sub>p</sub>  
to ISO 6081: 92 dB (A)

Equivalent sound power level L<sub>w</sub>  
to ISO 3744: 99 dB (A)

### Ignition System

Type: Electronic magneto ignition  
(breakerless)  
Ignition timing: 2.2-2.9 mm (0.09-0.11 in)  
B.T.D. C. at 7,000 rpm  
Spark plug  
(suppressed): NGK BPMR-7 A or  
Bosch WSR 6 F  
Heat range 200  
Electrode gap 0.5 mm (0.02 in)  
Spark plug thread: M 14×1.25;  
9.5 mm (0.37 in) long

### Fuel System

Carburetor: All position diaphragm carburetor with integral fuel pump  
Air filter: Foam filter  
Fuel tank capacity: 1.5 l (3.2 US pt)  
Fuel mixture: see chapter "Fuel"

### Blower

Air flow rate: 570 m<sup>3</sup>/h (335 cfm)  
at 7,800 rpm

### Weights

BR 106: 7.9 kg (17.4 lb)  
(complete, without  
special tool)

### Dimensions

Depth: 280 mm (11.0 in)  
(without blower tube)  
Width: 420 mm (16.5 in)  
Height: 443 mm (17.5 in)