

STIHL SR 320, 400

**Instruction Manual
Owner's Manual**

**Assembling
Safety Precautions
Operating Instructions
Maintenance**



Warning:
Always follow safety precautions in
Owner's Manual - improper use
can cause serious injury!

Contents

Controls	2	Maintenance Chart	37
Safety Precautions	4	Specifications	38
Assembly of Unit	11	STIHL Incorporated Federal Emission Control Warranty Statement	39
Fuel	14		
Fueling	15		
Control Handle	16		
Starting	17		
Air Filter	19		
Adjusting the Carburetor	20		
Operating Instructions	21		
Checking Spark Plug	22		
Replacing the Starter Rope and Rewind Spring	23		
Special Accessories	26		
Metering Unit	27		
Notes on Use of Mistblower	28		

This Manual contains operating and safety instructions for all STIHL SR 320, SR 400 mistblowers.

Pay special attention to the safety precautions outlined on pages 4 to 10. Allow only persons who understand this Manual to operate your mistblower.

To receive maximum performance and satisfaction from your STIHL mistblower, it is important that you read and understand the maintenance and safety precautions before using your mistblower.

Contact your STIHL dealer or the STIHL distributor for your area if you do not understand any of the instructions in this Manual.

Warning!

Because a mistblower is a high-speed tool, some special safety precautions must be observed as with any other power tool to reduce the risk of personal injury. Careless or improper use may cause serious or even fatal injury.

STIHL's philosophy is to continually improve all of its products. As a result, engineering changes and improvements are made from time-to-time. If the operating characteristics or the appearance of your mistblower differ from those described in this Manual, please contact your STIHL dealer for information and assistance.

STIHL®

Printed on chlorine-free paper

© 1999 Andreas Stihl AG & Co., Waiblingen
0458 352 3021. M0,15. G9. PM. Printed in USA

SR 320, 400

Controls

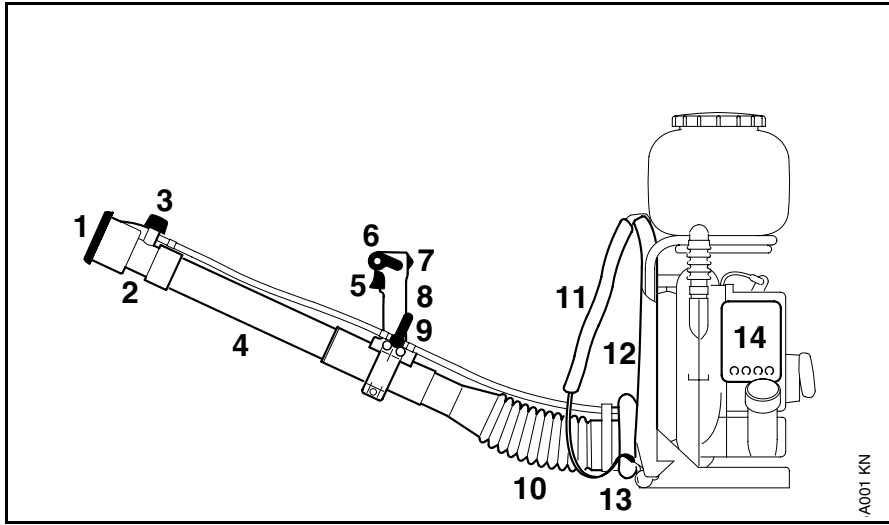

- 1 = Baffle screen
- 2 = Nozzle
- 3 = Metering knob
- 4 = Extension tube
- 5 = Throttle trigger
- 6 = Setting lever
- 7 = Stop switch
- 8 = Control handle
- 9 = Stop cock
- 10 = Pleated hose
- 11 = Carrying harness
- 12 = Back plate
- 13 = Back rest pad
- 14 = Air filter cover

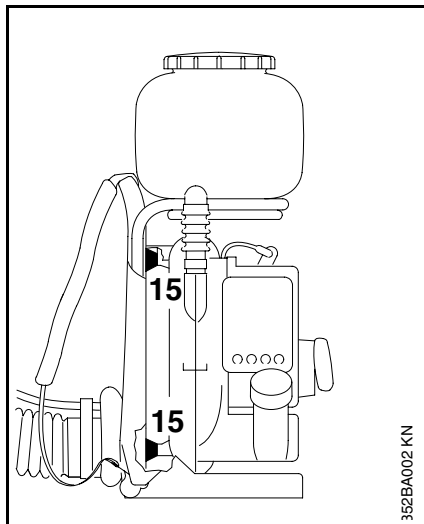

- 15 = Rubber buffers

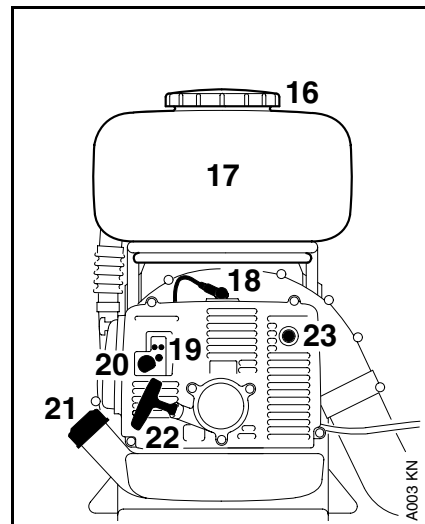

- 16 = Container filler cap
- 17 = Container
- 18 = Spark plug boot
- 19 = Carburator adjustment screws
- 20 = Choke knob
- 21 = Fuel filler cap
- 22 = Starter grip
- 23 = Muffler

Definitions

- 1. Baffle screen.**
To vary the direction and shape of the spray.
- 2. Nozzle.**
Directs and widens the spray.
- 3. Metering knob.**
For varying the spraying rate.
- 4. Extension tube.**
Accessory for lengthening the discharge tube.
- 5. Throttle trigger.**
Controls the speed of the engine.
- 6. Setting lever.**
Sets the throttle to various positions.
- 7. Stop switch.**
Stops engine.
- 8. Control handle.**
Handle on the flexible hose to hold and direct the tube in the required direction.
- 9. Stop cock.**
Opens and closes spray liquid hose.
- 10. Pleated hose.**
For spraying, dusting or spreading in the desired direction.
- 11. Carrying harness.**
For carrying the unit.
- 12. Back plate.**
Helps protect the back of the user.
- 13. Back rest pad.**
Increases carrying comfort.
- 14. Air filter cover.**
Covers the air filter element.
- 15. Rubber buffers.**
Elements designed to reduce the transmission of vibrations created by the engine to the operators back.
- 16. Container filler cap.**
For closing the container.
- 17. Container.**
Contains the material to be sprayed.
- 18. Spark plug boot.**
Connects the spark plug to the ignition wire.
- 19. Carburetor adjusting screws.**
For tuning carburetor.
- 20. Choke knob.**
Eases engine starting by enriching mixture.
- 21. Fuel filler cap.**
For closing the fuel tank.
- 22. Starter grip.**
The grip of the pull starter, which is the device to start the engine.
- 23. Muffler.**
Attenuates exhaust noises and diverts exhaust gases away from operator.

Safety Precautions

Warning!



The use of any mistblower may be dangerous. It is important that you read, fully understand and observe the following safety precautions and warnings.



Reread the owner's manual and the safety instructions periodically.



Warning!

Careless or improper use of the machine may cause serious injury. Have your STIHL Dealer show you how to operate your mistblower. Observe all applicable local safety regulations, standards and ordinances.



Warning!

Minors should never be allowed to use a mistblower: Bystanders, especially children, and animals should not be allowed in the area where a machine is in use. Never let the unit run unattended. Do not lend or rent your machine without the owner's manual. Be sure that anyone using your unit understands the information contained in this manual. Most of these safety precautions and warnings apply to the use of all STIHL mistblowers. Different models may have different parts and controls. See the appropriate section of your owner's manual for a description of the controls and function of the parts of your machine.

Safe use of a mistblower involves

1. the operator
2. the mistblower
3. the use of the mistblower .

THE OPERATOR

Physical Condition

You must be in good physical condition and mental health and not under the influence of any substance (drugs, alcohol, etc.) which might impair vision, dexterity or judgment. Do not operate a mistblower when you are fatigued. Be alert - if you get tired while operating your machine, take a break. Tiredness may result in loss of control. Working with any mistblower can be strenuous. If you have any condition that might be aggravated by strenuous work, check with your doctor before operating the machine.



Warning!

Prolonged use of a mistblower, (or other machines) exposing the operator to vibrations may produce whitefinger disease (Raynaud's phenomenon) or carpal tunnel syndrome. These conditions reduce the hand's ability to feel and regulate temperature, produce numbness and burning sensations and may cause nerve and circulation damage and tissue necrosis.

All factors which contribute to whitefinger disease are not known, but cold weather, smoking and diseases or physical conditions that affect blood vessels and blood transport, as well as high vibration levels and long periods of exposure to vibration are mentioned as factors in the development of whitefinger disease. In order to reduce the risk of whitefinger disease and carpal tunnel syndrome, please note the following:

- Most STIHL power tools are available with an anti-vibration ("AV") system designed to reduce the transmission of vibrations created by the engine to the operator's hands. An AV system is recommended for those persons using power tools on a regular or sustained basis.
- Wear gloves and keep your hands warm.
- Keep the AV system well maintained. A mistblower with loose components or with damaged or worn AV buffers will tend to have higher vibration levels.
- Maintain a firm grip at all times, but do not squeeze the handles with constant, excessive pressures, take frequent breaks.

All the above mentioned precautions do not guarantee that you will not sustain whitefinger disease or carpal tunnel syndrome. Therefore continual and regular users should monitor closely the condition of their hands and fingers. If any of the above symptoms appear, seek medical advice immediately.

Proper Clothing

Clothing must be sturdy and snug-fitting, but allow complete freedom of movement. Avoid loose-fitting jackets, flared or cuffed pants, scarfs, unconfined long hair or anything that could be drawn into the air intake.



Wear overalls or long pants to protect your legs. Do not wear shorts. Use of gloves when working with the mistblower is recommended.

Good footing is most important. Wear sturdy shoes with nonslip soles.



To reduce the risk of injury associated with the inhalation of dust, use a face filter mask. When using the mistblower, follow all of the chemical manufacturers instructions with respect to proper eye, skin, nose and mouth protection. When working in greenhouses, make sure they are well ventilated and, if necessary wear a respirator.



Warning!
Proper eye protection is a must. Even though the discharge is directed away from the operator, ricochets and bounce-backs can occur during mistblower operations.



Never operate a mistblower unless wearing goggles or properly fitted safety glasses with adequate top and side protection which comply with ANSI Z 87.1 (or your applicable national standard).

Fellow workers must also wear eye protection.

Mistblower noise may damage your hearing. Wear sound barriers (ear plugs or ear muffers) to protect your hearing. Continual and regular users should have their hearing checked regularly.

Cloth soaped with chemical solutions has to be changed immediately.

THE MISTBLOWER

For illustrations and definitions of the mistblower parts see the chapter on "Parts and Controls"!



Warning!
Never modify a mistblower in any way. Only attachments supplied by STIHL or expressly approved by STIHL for use with the specific STIHL mistblower models are authorized. Although certain unauthorized attachment are useable for the STIHL mistblower, their use may be extremely dangerous.

THE USE OF THE MISTBLOWER

Transport

Always turn off the engine before taking the machine off your back and putting it down. When transporting your unit in a vehicle, properly secure it to prevent turnover, fuel spillage and damage to the machine.



Warning!
Before starting work, always inspect the rubber buffers which connect the engine to the pack frame. If the buffers are torn or damaged, they should be replaced by your STIHL dealer. Failure of one or more buffers may cause the engine or fuel tank to hit or rub against other parts, and may lead to serious injury from increased vibrations or from fire as the result of fuel leakage.

Adjust carrying harness to suit your size before starting work.

Fueling

This STIHL unit uses an oil-gasoline mixture for fuel (see the chapter on "Fuel" of your owner's manual).



Warning!



Gasoline is an extremely flammable fuel. If spilled or ignited by a spark or other ignition source, it can cause fire and

serious burn injury or property damage. Use extreme caution when handling gasoline or fuel mix.

Do not smoke or bring any fire or flame near the fuel.

Fueling instructions

Fuel your machine in well-ventilated areas, outdoors only. Always shut off the engine and allow it to cool before refueling. Relieve fuel tank pressure by loosening fuel cap slowly. Never remove fuel filler cap while engine is running.

Select bare ground for fueling and move at least 10 feet (3 m) from the fueling spot before starting the engine. Wipe off any spilled fuel before starting your mistblower and check for leakage. Always tighten fuel filler cap securely after fueling.



Warning!

To reduce the risk of serious injury from burns, never attempt to refuel the unit until it has been completely removed from the operator.



Warning!

Check for fuel leakage while refueling and during operation. If fuel or oil leakage is found, do not start or run the engine until leak is fixed and spilled fuel has been wiped away. Take care not to get fuel on your clothing. If this happens, change your clothing immediately.

Always store gasoline in approved container.



Warning!

Unit vibrations can cause an improperly tightened fuel cap to loosen or come off and spill quantities of fuel.



In order to reduce risk of fuel spillage and fire, tighten fuel cap by hand with as much force as possible.

Starting

You should always inspect your unit before starting it. Make sure the controls and safety devices are working properly.



Warning!

Your mistblower is a one-person machine. To reduce the risk of eye or other injury from thrown objects, insure that bystanders are at least 50 feet (15m) away during use.

Stop the engine immediately if you are approached.

The assistance of another person may be needed in placing the unit on your back after starting. In order to reduce the risk of injury to the assistant from thrown objects or from contact with fumes, the engine should be kept at idle speed during this brief period, and your assistant should not stand in the area of the outlet nozzle or exhaust. Otherwise,

the unit should be started and operated without assistance.

For specific starting instructions, see the appropriate section of your owner's manual. Place the machine on firm ground or other solid surface in an open area. Maintain good balance and secure footing.

Warning!

When you pull the starter grip, don't wrap the starter rope around your hand. Do not allow the grip to snap back, but guide the starter rope slowly back to permit the rope to rewind properly. Failure to follow this procedure may result in injury to hand or fingers and may damage the starter mechanism.

Working instructions and important adjustments

Warning!

Never operate your machine if it is damaged, improperly adjusted or not completely and securely assembled.

Warning!

Start and operate your unit outdoors in a ventilated area.

Warning!



Your mistblower produces poisonous exhaust fumes as soon as the combustible engine is running. These gases (e.g. carbon monoxide) may be colorless and odorless.

To reduce the risk of serious or fatal injury from breathing toxic fumes, never run the mistblower indoors or in poorly ventilated locations. Ensure proper ventilation when working in trenches or other confined areas. Keep the space behind the engine clear at all times to allow for the escape of hot and toxic exhaust fumes.

Operate your machine under good visibility and daylight conditions only. Work carefully.

Working Conditions

When working with the mistblower, always wear it on your back using the carrying harness. Wrap your fingers tightly around the handle, keeping the control handle cradled between your thumb and forefinger. Keep your hand in this position to have your machine under control at all times.

Make sure your control handle and grip is in good condition and free of moisture, pitch, oil or grease.

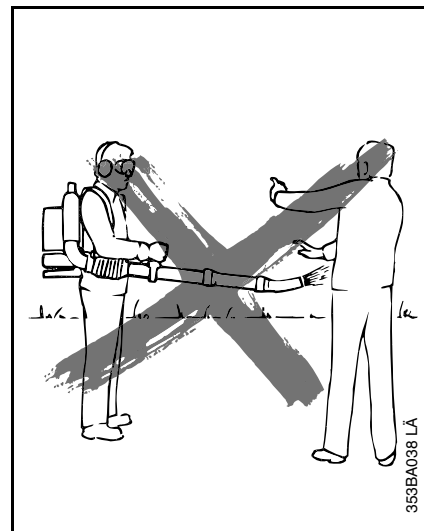

Warning!

To reduce the risk of personal injury, do not direct air blast towards bystanders, since the high pressure of the air flow could injure eyes and could blow small objects at great speed.

Mistblowers may also be used in greenhouses which are well ventilated if the operator can protect himself from any harmful effects through the use of proper eye, skin, nose and mouth protection. Breathing exhaust fumes or toxic chemicals in mist can cause serious or fatal injury.

**Warning!**

Never insert any foreign object into the air intake of the machine or into the nozzle of the mistblower. It will damage the fan wheel and may cause serious injury to the operator or bystanders as a result of the object or broken parts being thrown out at high speed.

Do not place the mistblower on the ground when operating at high speed, because small objects such as sand, grass, dust, etc. may be pulled into the air intake and damage the fan wheel.

In the event of the machine catching fire (for whatever reason) throw it off quickly by releasing the spring catches on both sides of the harness.

In an emergency, you may slip out of the harness and throw off the machine quickly by first releasing the lap belt - on machines that are so equipped - and then lifting the tabs of the two sliding harness adjusters to slacken the shoulder straps. Try this procedure a number of times before using the machine in order to become accustomed with it. Pay attention to the direction of the wind, i.e., do not work against the wind.

To reduce the risk of stumbling and loss of control, do not walk backward while operating the machine.

Pay attention to the direction of the wind, i.e. do not work against the wind. Do not direct air blast towards bystanders.

Operating Instructions

The mistblower may be used only for the operations described in your manual.

Use of Chemicals with Mistblower**Warning!**

Exercise extreme caution when handling chemicals. Follow all safety precautions and instructions laid down by the manufacturer. Avoid contact with chemicals and chemical solutions. Be sure the mistblower is the proper tool for the job.

**Warning!**

Do not spray flammable liquids; such as gasoline or paint thinner. Such substances create a risk of fire or explosion and may damage the mistblower. Do not spray caustic or acid solutions. Contact with such substances may cause serious or fatal injury or damage the property, including the mistblower.

**Warning!**

When spraying, stand so that the wind blows the spray away from you and bystanders. Keep children and pets away from areas that have just been sprayed.

**Warning!**

Always empty and clean the liquid container after each use. Residual chemicals may have undesirable effects during subsequent spraying with a different type of chemical (e.g., residual herbicide may damage or kill plants being sprayed with a pesticide). It is best to fill the container with clean water and let it drain out with the tap open. Be cautious where you drain the liquid during the cleaning process.

Never store liquid in the container for more than one day.

Use of the Mistblower

The mistblower can be used for spraying chemicals and liquids to control pests and weeds in fruit and vegetable gardens, on trees and bushes, citrus, coffee, tobacco, cotton and many other areas. It is also useful in the maintenance of young trees, controlling the bark beetle and other plant diseases.

Filling the Container

To reduce the risk of contaminating the surrounding environment, be careful not to overfill the container with chemical solution.

If you fill the container with a hose attached to a water pipe be sure the end of the hose is out of the solution to reduce the risk of chemicals being sucked into the water pipe in the case of a sudden vacuum.

Calculate the correct amount of chemical solution so that it is used up at one time.

MAINTENANCE, REPAIR AND STORING

Maintenance, replacement, or repair of the emission control devices and systems may be performed by any nonroad engine repair establishment or individual. However if you claim warranty for a component which has not been serviced or maintained properly or if nonapproved replacement parts were used, STIHL may deny warranty.

Use only identical STIHL replacement parts for maintenance and repair. Use of parts manufactured by others may cause serious or fatal injury.

Follow the maintenance and repair instructions in the appropriate section of your owner's manual. Refer to the maintenance chart at the end of this manual.

Warning!

Always stop the engine and make sure that the fan is stopped before doing any maintenance or repair work or cleaning the mistblower. Do not attempt any maintenance or repair work not described in your owner's manual. Have such work performed at your STIHL service shop only.

Check fuel filler cap for leaks at regular intervals. Use the specified spark plug and make sure it and the ignition lead are always in good condition.

Warning!

A worn or damaged muffler is a fire hazard and may cause loss of hearing. Check to see that the muffler is in good condition. The mistblower must not be operated if the muffler is not functioning properly or has been removed.

Remember that the risk of forest fires is greater in hot weather. Use the spark arresting muffler supplied with the unit. Never touch a hot muffler or burn will result.



Warning!

In order to reduce the risk of fire, do not modify or remove any part of the muffler or spark arrestor.

Tighten all nuts, bolts and screws except the carburetor adjustment screws after each use.

Keep spark plug and wire connection tight and clean. The spark plug electrode gap should be checked with a feeler gauge at least every 50 operating hours and reset if necessary. Fit a new spark plug if the electrodes are badly pitted.

For any maintenance please refer to the maintenance chart **and to the warranty statement** near the end of this manual.

Store mistblower in a dry, high or locked location place and out of reach of children.

Before storing for longer than a few days, always empty the fuel tank.

Assembly of Unit

The unit is partly disassembled for ease of shipment and must be completely assembled before it is used for the first time.

The tools on the underside of the unit (1 combination wrench and 1 carburetor screwdriver) should be used for the assembly work.

Mounting the elbow

- Line up the stops on the elbow (1) and fan housing stub (2).
- Push the elbow (1) into the stub (2) as far as it will go.
- Fit a nut (3) into each of the molded hexagon seats on the stub.
- Insert a screw (4) into each nut from the other side and tighten moderately (it must still be possible to turn the elbow).

Important: The throttle cable with integrated stop switch wire is already connected to the control handle and the engine and must not be kinked during assembly.

- Attach throttle cable with the retainer (5) to the pleated hose.

Mounting the spraying attachment

Insert extension tube (12) into the pleated hose (7) as far as it will go.

- Rotate the pleated hose (7) to the left (counterclockwise) as far as the stop and leave it in that position until you have completed the following adjustments.

Top: Elbow fitted to fan housing

Center: Spraying attachment fitted

Bottom: Stop cock lever in vertical position

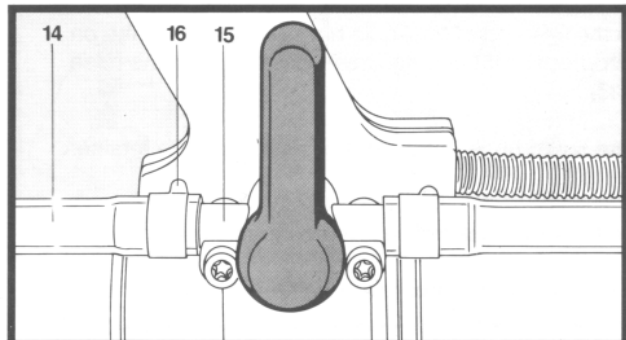
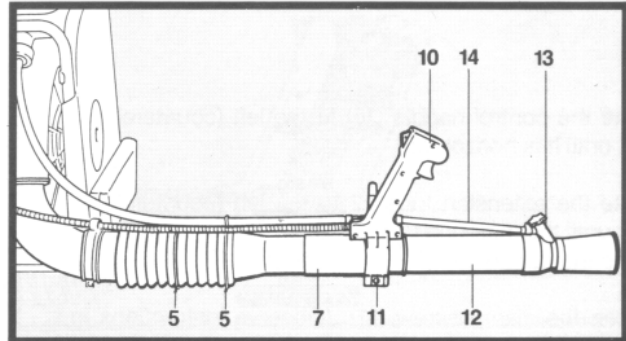
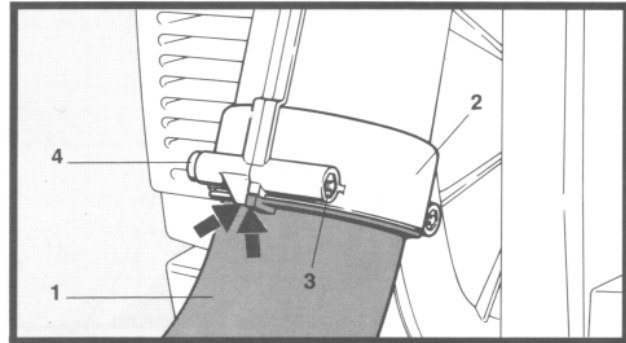

- Rotate the control handle (10) to the left (counterclockwise) until it is horizontal.
- Rotate the extension tube 12 to the left (counterclockwise) until the metering unit (13) points in the same direction as the control handle.
- Tighten the clamp screw (11). (Observe instructions in chapter "Adjusting the control handle")
- Push the free end of the liquid hose (14) over the stub on the stop cock (15) and secure in position with the hose clip (16).
- Secure liquid hose to the pleated hose with the retainer (5).
- Close the stop cock (move lever to vertical position).

Fill up with spray mix and check all hose connections for leaks.

The pivot-mounted pleated hose allows the blower tube or spraying attachment to be rotated about 90° to the left or right (i.e. counterclockwise or clockwise) from the center position (control handle vertical).

Adjusting the control handle

You can adjust the position of the control handle on the pleated hose to suit your reach.

Carry out the adjustment as follows:

- Put the unit on your back.
- Release the clamp screw (11).
- Slide the control handle along the pleated hose to the most comfortable position.
- Retighten the clamp screw (11).

Adjusting the harness straps

The harness straps are attached to the backplate and have sliding adjusters for adjustment to any required length.

Pull the ends of the straps downward to tighten the backplate against your back. Lift the tabs of the two sliding adjusters to slacken the harness straps.

Adjust the straps so that the backplate is held firmly and securely against your back.

Top: Range of rotation of tube
Center: Range of adjustment of control handle
Bottom: Pulling ends of straps downward (left)
Lifting tabs of strap adjusters (right)

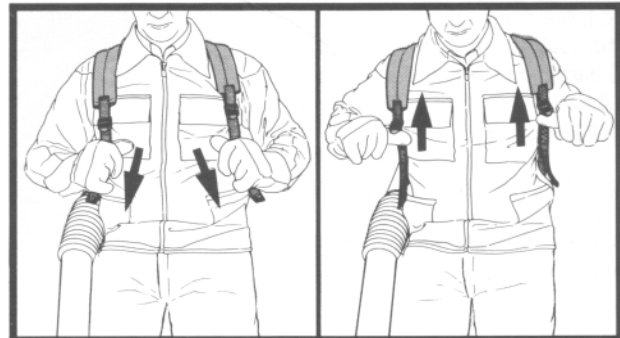
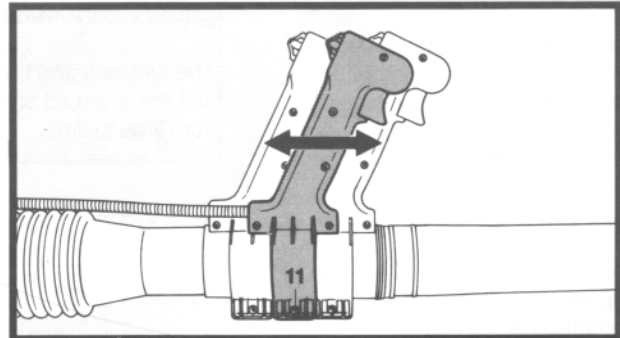
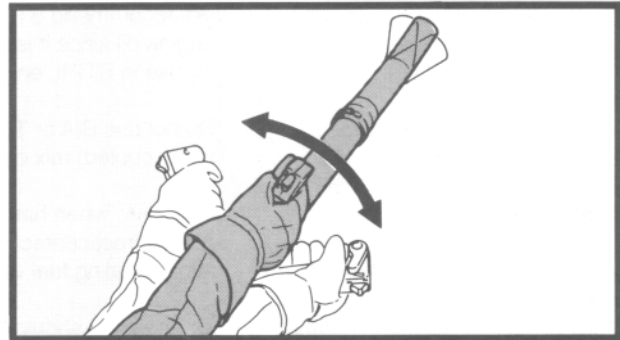

Fuel

This engine is certified to operate on unleaded gasoline and with the mix ratio 50:1.

Your two-stroke engine requires a mixture of brand-name gasoline and quality two-stroke engine oil with the classification TC.

Use regular branded unleaded gasoline with a minimum octane rating of 90 RON (U.S.A./Canada: pump octane min. 89!). If the octane number of the regular grade gasoline in your area is lower use premium unleaded fuel.

Fuel with a lower octane rating may result in preignition (causing "pinging") which is accompanied by an increase in engine temperature. This, in turn, increases the risk of the piston seizure and damage to the engine.

The chemical composition of the fuel is also important. Some fuel additives not only detrimentally affect elastomers (carburetor diaphragms, oil seals, fuel lines etc.), but magnesium castings as well. This could cause running problems or even damage the engine. For this reason it is essential that you use only name branded fuels!

Use only STIHL two-stroke engine oil or equivalent branded two-stroke air-cooled engine oils with the classification TC for mixing.

We recommend STIHL 50:1 two-stroke engine oil since it is specially formulated for use in STIHL engines.

Do not use BIA or TCW (two-stroke water cooled) mix oils!

Take care when handling gasoline. Avoid direct contact with the skin and avoid inhaling fuel vapour.

The canister should be kept tightly closed in order to avoid any moisture getting into the mixture.

The fuel tank and the canister in which fuel mix is stored should be cleaned from time to time.

Fuel mix ages:

Only mix sufficient fuel for a few days work, not to exceed 3 months of storage. Store in approved safety fuel-canisters only. When mixing, pour oil into the canister first, and then add gasoline.

Gasoline	Oil (STIHL 50:1 or equivalent branded TC oils)
US gal.	US fl.oz
1	2.6
2 1/2	6.4
5	12.8

Dispose empty mixing-oil canisters only at authorized disposal locations.

Fueling

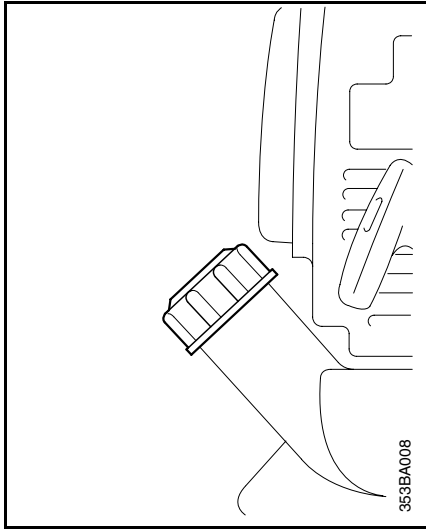

Before fueling, clean the filler cap and the area around it to ensure that no dirt falls into the tank.

Always thoroughly shake the mixture in the canister before fueling your machine.

Warning!

In order to reduce the risk of burns or other personal injury from escaping gas vapor and fumes, remove the fuel filler cap carefully so as to allow any pressure build-up in the tank to release slowly.

Warning!

After fueling, tighten fuel cap as securely as possible by hand.

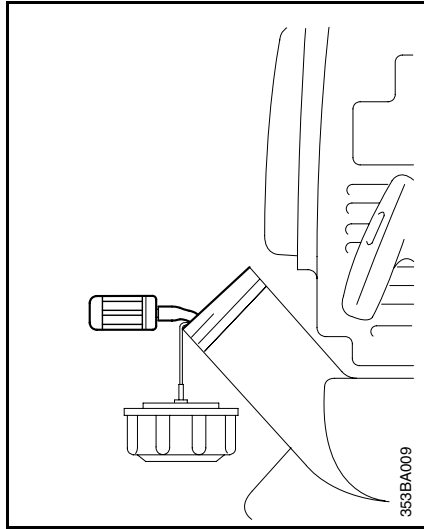

Change the fuel pick up body every year.

Before storing your machine for a long period, drain and clean the fuel tank and run engine until carburetor is dry.

Control Handle

The control handle has two functions. It is used to aim the airstream or the spray in the required direction.

The controls (stop switch, throttle trigger and setting lever) are used to select the required engine operating condition.

The stop switch (1) shuts down the engine. The engine is ready to start when the stop switch is in the "I" position. Ignition is interrupted, i.e. the engine stops or will not start, when the stop switch is in the "O" position.

Engine speed can be infinitely varied between idling and maximum speed with the throttle trigger (2).

The setting lever (3) enables any engine speed or throttle position between idling and maximum speed to be selected and held. To do this, swing the setting lever upward to the required position. The setting lever automatically remains in the position selected. The engine runs at idling speed when the setting lever is moved back to its lower end position (see illustration). Always move the setting lever to this end position before shutting down the engine.

The mistblower's control handle also features a stop cock for the spray mix. Its lever (4) must be set parallel to the pleated hose for maximum flow and returned to the vertical position to shut off the flow.

Top: Control handle with stop switch, throttle trigger and setting lever

Center: Setting lever in lower end position

Bottom: Stop cock lever

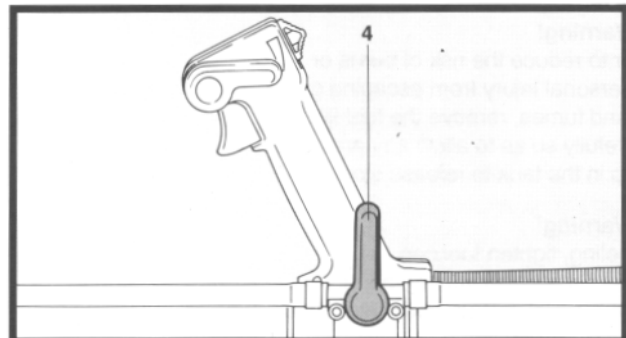
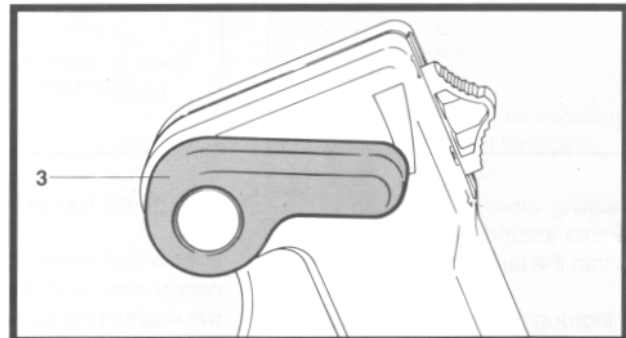
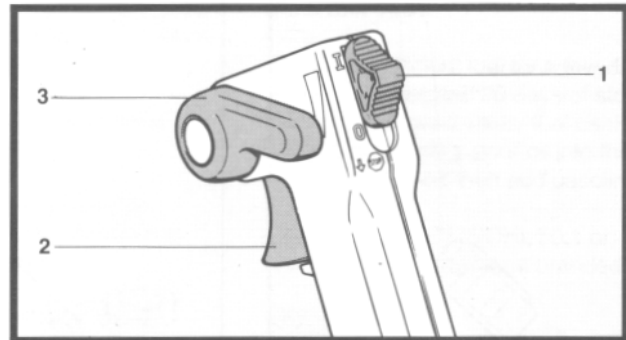

Starting

Before starting, place the unit on a clear patch of ground. Make sure you have a firm foothold, keep a firm grip on the machine and check that there are no objects which could be sucked in by the fan (between engine and backplate).

1. Starting procedure

- 1.1 Slide the stop switch (1) to "I". Move the setting lever (3) to the midway position between the two end stops. The throttle trigger (2) is now in the "starting throttle" position.
- 1.2 If the engine is cold: Turn the rotary choke knob (4) in the direction of the arrow  (choke).
- 1.3 If the engine is warm: Turn the rotary choke knob (4) in the opposite direction to the arrow.

Note: This procedure also applies if the engine has been running but is still cold.

Top: Throttle trigger and setting lever in "start" position
Center: Rotary choke knob in "cold start" position
Bottom: Rotary choke knob in "warm start" position

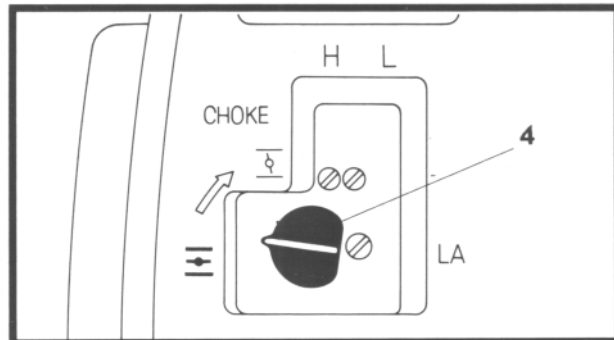
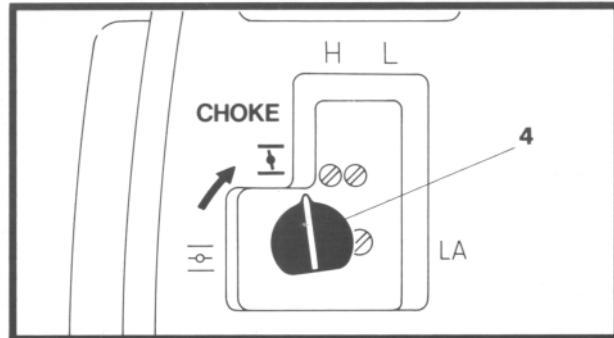
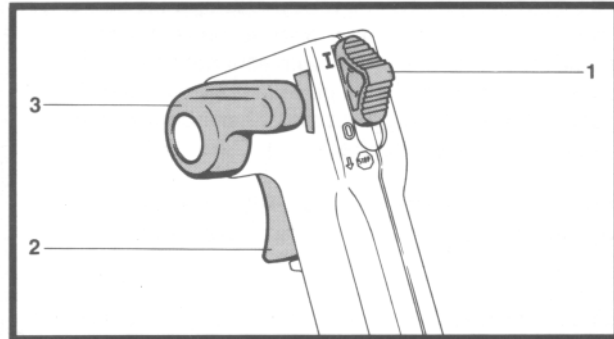

- To start, hold the top of the machine with your left hand and put one foot on the base plate to prevent it slipping. Pull the starter grip slowly with your right hand until you feel it engage and then give it a brisk strong pull. Do not pull the starter rope out more than about 70 cm (27") as it might otherwise break.

Do not allow the starter rope to snap back. Guide it slowly back into the housing so that it can rewind correctly.

Continue cranking the engine until it begins to fire. Then open the choke immediately (turn rotary knob away from arrow) and continue cranking.

- Once the engine is running, move the setting lever (3) immediately to its lower end position (ill.) so that the engine can settle down to idle speed.
- To stop the engine, slide the stop switch (1) to "STOP".

Top: Starting
Center: Setting lever in Lower end position
Bottom: Stop switch on "STOP"

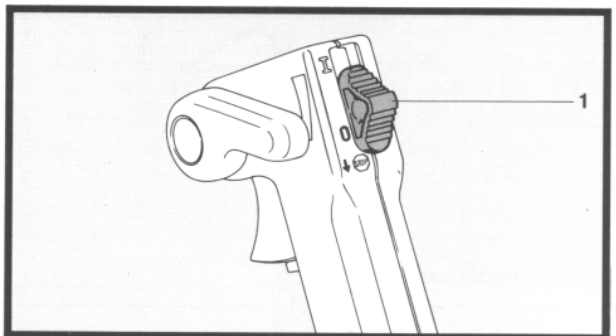
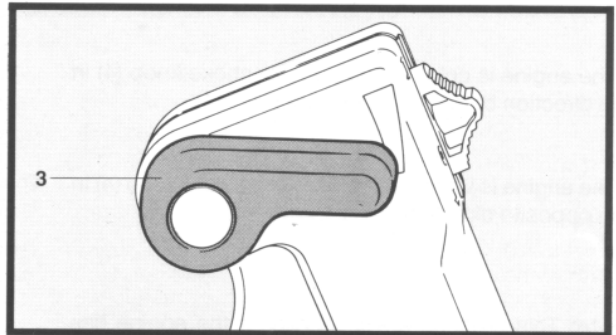
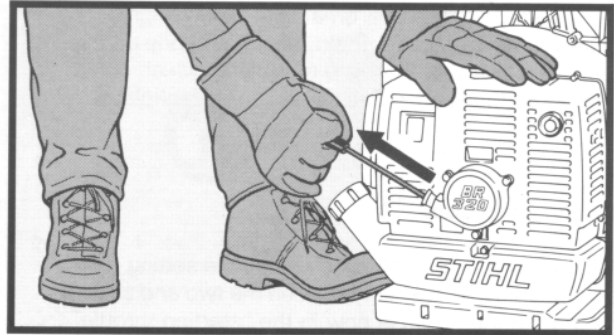

Erratic idling behavior; poor acceleration

Idle setting too lean; turn low speed adjusting screw (2) counterclockwise until engine runs and accelerates smoothly.

Exhaust smokes at idle speed

Idle speed setting too rich; turn low speed adjusting screw (2) clockwise until engine speed drops. Then turn screw back one quarter turn and check that engine still accelerates smoothly when you open the throttle.

A correction at the low speed adjusting screw usually necessitates a change in the setting of the idle speed adjusting screw (3).

Apart from minor adjustments, you should leave all carburetor setting and repair work to your STIHL dealer. STIHL dealers have trained staff and all the necessary servicing tools and equipment.

Air Filter

Component parts in correct sequence

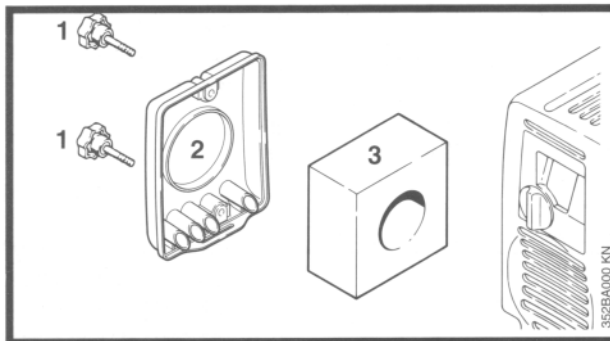

The purpose of an air filter is to prevent any dust and dirt in the intake air from entering the carburetor and thus protect the moving parts of the engine from abnormal wear. Dirty air filters reduce engine power, increase fuel consumption and make starting more difficult.

The air filter must, therefore, be cleaned or replaced when there is a noticeable loss of engine power.

Before removing the air filter, close the choke (turn rotary knob in direction of arrow) to prevent dirt falling into the carburetor. Remove the screw (1) and take off the filter cover (2) and the filter (3)

Wash the filter (3) in a fresh, non-inflammable cleaning solution and allow to dry.

Never refit a damaged filter element, always fit a new one.

Adjusting the Carburetor

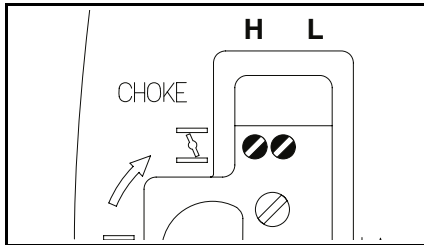

Motormanagement

Exhaust emissions are controlled by the design of the fundamental engine parameters and components (e.g. carburation, ignition, timing and valve or part timing) without the addition of any major hardware.

The carburetor comes with a standard setting.

This is the optimum setting to ensure your machine will operate reliably with the lowest possible emission under most operating conditions.

Standard setting

If it is necessary to readjust the carburetor from scratch, first carry out the standard setting.

Turn

H = high speed adjusting screw and
L = low speed adjusting screw
counterclockwise (richer)
or as far as stop.

If you don't have a tachometer, do not set the high speed adjusting screw any leaner by turning it beyond the standard setting.

Operation at high altitude (mountains) -

Slight correction **may** be necessary. Use a **tachometer** to set the high speed adjusting screw (**H**) to obtain the highest possible engine speed. From that position, turn the high speed adjusting screw (**H**) 1/8 counterclockwise (richer) or as far as stop. Avoid risk of engine damage which can be caused by lack of lubrication and overheating -

- Check air filter and clean it if necessary.
- Set idle speed correctly.
- Warm up the engine.
Turn the high speed adjusting screw (**H**) and low speed adjusting screw (**L**) clockwise (leaner) at higher altitudes.

Turn the screws very slowly and carefully - slight changes have a noticeable effect on the engine's running behavior.

Corrections to high speed adjusting screw:

The high speed adjusting screw (**H**) alters the power output and maximum off-load engine speed. If you turn this screw too far clockwise and make the setting too lean, there is a risk of engine damage.

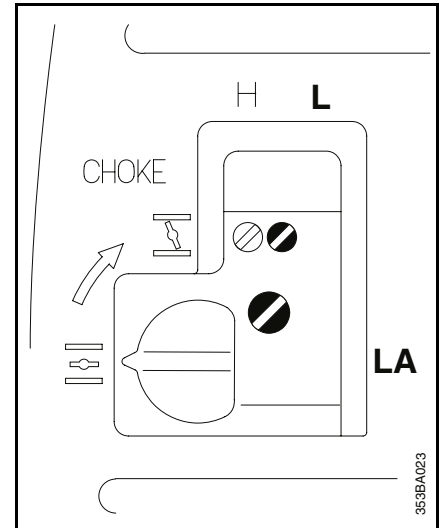

Setting idle speed

It is usually necessary to change the setting of the idle speed adjusting screw (**LA**) after every correction to the low speed adjusting screw (**L**).

Engine stops while idling

Turn the idle speed adjusting screw (**LA**) clockwise until the engine runs smoothly.

Erratic idling behavior, poor acceleration

Idle setting is too lean.
Turn the low speed adjusting screw (**L**) counterclockwise until engine runs and accelerates smoothly.

Operating Instructions

During break-in period

A factory new machine should not be run at high revs (full throttle off load) for the first three tank fillings. This avoids unnecessary high loads during the break-in period.

As all moving parts have to bed in during the break-in period, the frictional resistances in the engine are greater during this period. The engine develops its maximum power after about 5 to 15 tank fillings.

During operation

After a long period of full-throttle operation, allow engine to run for a while at idle speed so that the heat in the engine can be dissipated by flow of cooling air. This protects engine-mounted components (ignition, carburetor) from thermal overload.

After finishing work

Storing for a short period:
Wait for engine to cool down. To avoid condensation, fill the fuel tank and keep the unit in a dry place until you need it again.

Storing for an long period:
see chapter "Storing the Machine".

Storing the Machine

For periods of about 3 months or longer:

- Drain and clean the container.
- Drain and clean the fuel tank.
- Run engine until carburetor is dry - this helps prevent the carburetor diaphragms sticking together.
- Thoroughly clean the machine - pay special attention to the cylinder fins and air filter.
- Store the machine in a dry, high or locked location - out of the reach of children and other unauthorized persons.

Checking Spark Plug

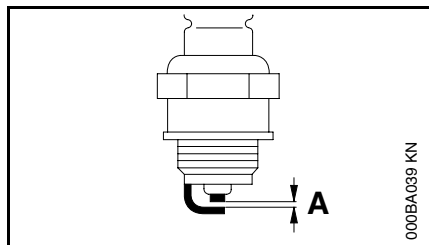

- Use only resistor type spark plugs of the approved range.

Rectify problems which have caused fouling of spark plug:
Incorrect carburetor setting, too much oil in fuel mix, dirty air filter, unfavorable running conditions, e.g. operating at part load.

- Fit a new spark plug after approx. 100 operating hours - or earlier if the electrodes are badly eroded.

Warning!

To reduce the risk of fire and burn injury, use only spark plugs authorized by STIHL (see "Specifications"). Always press spark plug boot (2) snugly onto spark plug terminal (1) of the proper size. (Note: If terminal has detachable SAE adapter nut, it must be attached.) A loose connection between spark plug terminal and ignition wire connector in the boot may create arcing that could ignite combustible fumes and cause a fire.

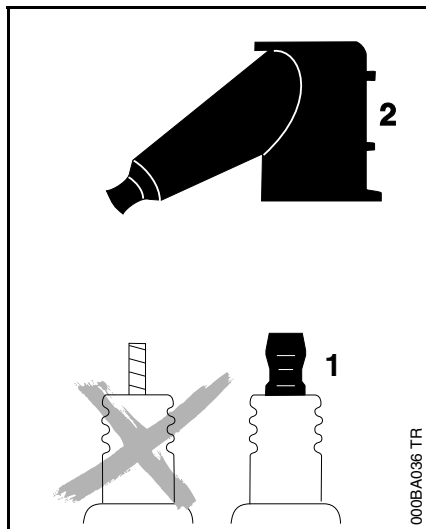

Wrong fuel mix (too much engine oil in the gasoline), a dirty air filter and unfavorable running conditions (mostly at part throttle etc.) affect the condition of the spark plug. These factors cause deposits to form on the insulator nose which may result in trouble in operation.

If engine is down on power, difficult to start or runs poorly at idling speed, first check the spark plug.

- Remove spark plug - see chapter "Starting":
- Clean dirty spark plug.
- Check electrode gap - it should be 0.5mm/0.02" (A) - readjust if necessary.

Replacing Starter Rope and Rewind Spring

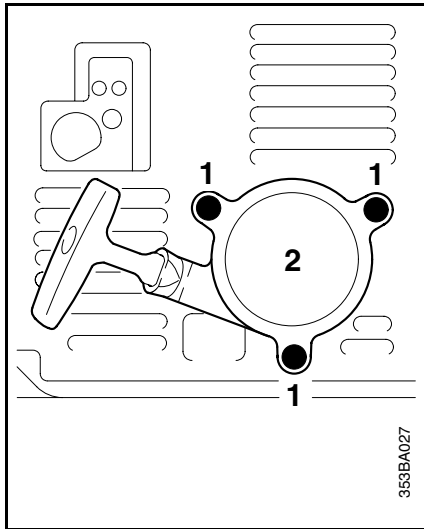

- Remove the three screws (1).
- Lift the starter cover (2) off the engine.

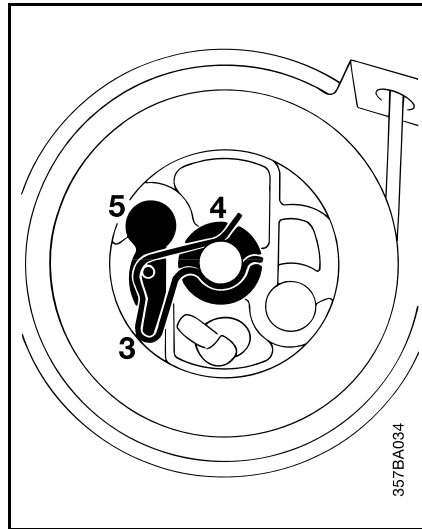

- Remove the spring clip (3).
- Remove the rope rotor with washer (4) and pawl (5).

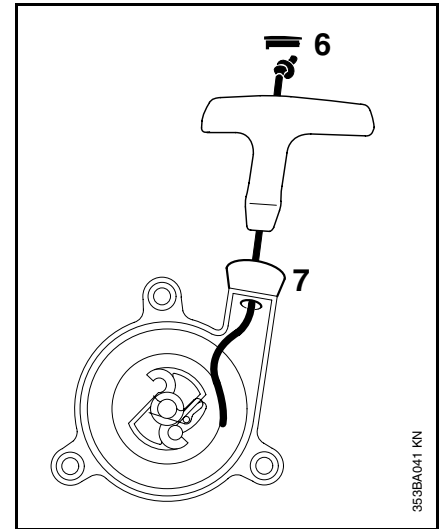

- Ease the cap (6) out of the starter grip.
- Remove remaining rope from the rotor and grip.
- Tie a simple overhand knot in the end of the new starter rope - 1113 195 8200 - and then thread the rope through the top of the grip and the rope bush (7).
- Refit the cap in the grip.

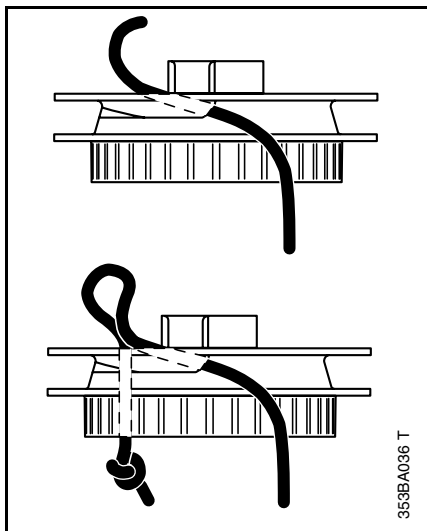

- Thread the rope through the rotor and secure it with a simple over-hand knot.

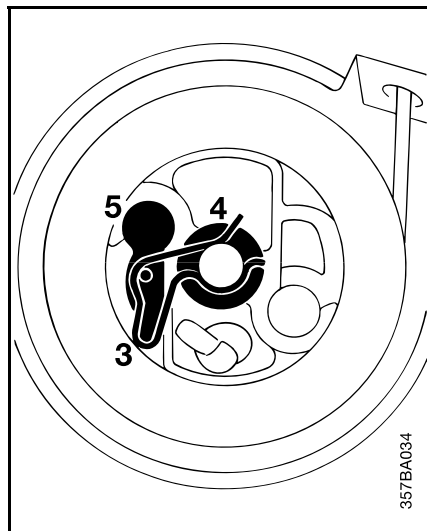

- Coat rope rotor bearing bore with non-resinous oil.
- Slide rotor onto starter post - turn it back and forth so that anchor loop of rewind spring engages -
- Refit the pawls (5) in the rotor -
- Fit the washer (4) on the starter post
- Use screwdriver or suitable pliers to install spring clip (3) on starter post and over the pawl pegs - the spring clip must point in clockwise direction - see illustration.

Replacing a broken rewind spring

- Lubricate the new spring with a few drops of non-resinous oil -
- Remove the rope rotor - see "Replacing Starter Rope" -
- Remove parts of old spring.

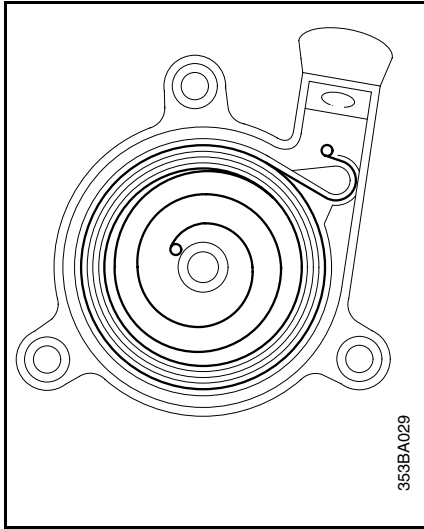

- Fit new spring housing - bottom plate must face downward. Engage outer spring loop over the lug.
- Refit the rope rotor. Go to "Tensioning rewind spring".
- If the spring has popped out and uncoiled: Refit it in the counterclockwise direction - start outside and work inward.

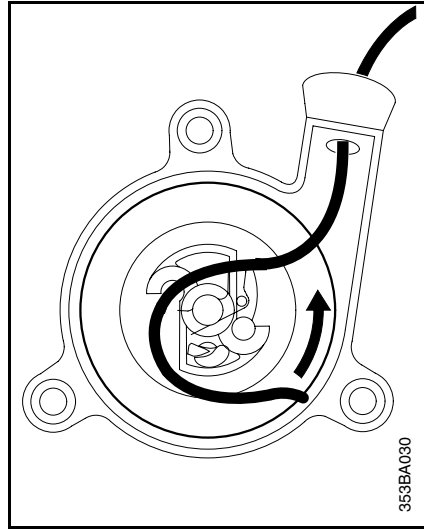

Tensioning rewind spring

- Make a loop in the unwound starter rope and use it to turn the rope rotor six full revolutions in the direction of the arrow
- Hold the rotor steady - straighten the twisted rope -
- Release the rotor -
- Let go of rope slowly so that it winds onto the rotor.
The starter grip must sit firmly in the rope guide bush. If the grip droops to one side: Increase spring tension by one additional turn.

- When starter rope is fully extended it must be possible to rotate the rotor at least another half turn. If this is not possible, the spring is over-tensioned and could break. Take off one turn of the rope.
- Fit the fan housing on the crankcase.
- Tighten down the screws firmly.
- Set the Master Control lever to 

Special accessories

Lap belt

The lap belt is standard on some models and can be retrofitted to all mistblowers. It ensures that the backplate is always positioned snugly against the user's back.

Back padding

Additional back padding is available to further enhance wear comfort. It is attached to the backplate next to the standard padding.

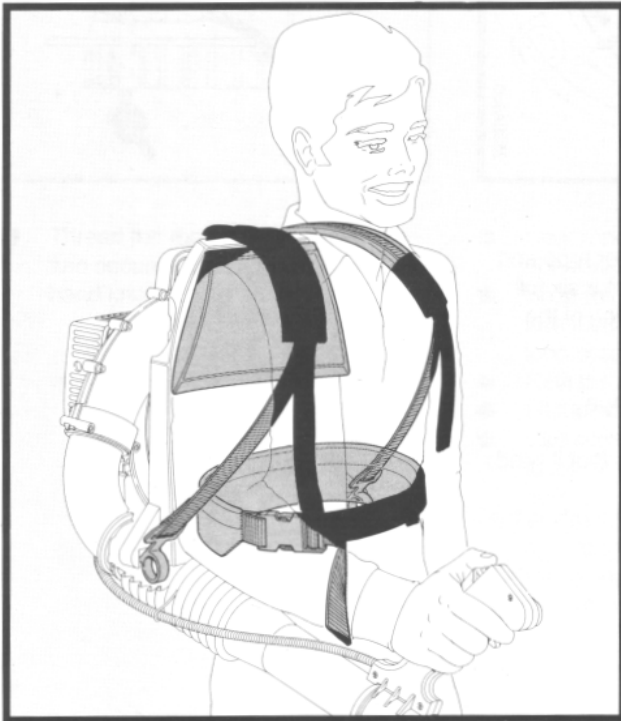

Dusting and spreading attachment (SR 320, SR 400)

Equipped with this attachment, sprayers can apply chemicals and other substances which come in granulated or powder form (e. g. fertilizers, grass seed etc.).

Booster pump kit (SR 320, SR 400)

The booster pump constantly agitates the spray mix and ensures a uniform spray rate, regardless of the position in which the mistblower tube is held.

ULV rotary nozzle kit (SR 320, SR 400)

Units equipped with the ULV rotary nozzle are capable of spreading very small quantities of special chemicals. To guarantee constant spray rates with the ULV rotary nozzle, the unit has to be additionally equipped with the booster pump kit.

Metering Unit

The flow rate can be infinitely varied by means of the metering knob (1) on the nozzle (2). Metering knob position "1" is the minimum flow rate and "6" the maximum.

The required number on the metering knob (1) must be lined up with the molded lug (3).

The numbers on the metering knob (1) represent the following spray rates:

1. Spray rate without booster pump

Metering knob position	Spray rate without baffle		SR 320, SR 400 with baffle	
	l/min	(US gal/h)	l/min	(US gal/h)
1	0.13	(2.0)	0.14	(2.3)
2	0.61	(9.5)	0.71	(11.1)
3	1.27	(20.2)	1.33	(21.0)
4	1.92	(30.5)	2.09	(33.2)
5	2.49	(39.2)	2.67	(42.4)
6	2.78	(43.9)	3.03	(47.5)

2. Spray rate with booster pump (metering knob position 6)

Metering nozzle	Spray rate l/min		(US gal/h)	
	SR 320	SR 400	SR 320	SR 400
1	0.53	(8.3)	0.57	(9.1)
2	1.42	(22.5)	1.54	(24.5)
3	2.44	(38.8)	2.32	(36.8)

Nozzle with metering unit

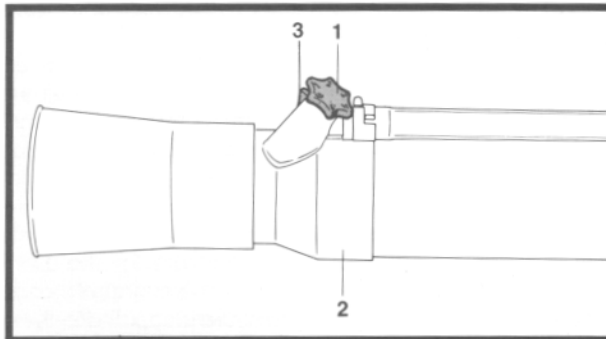

Checking the metering unit (without booster pump)

- Place the unit on the ground.
- Fill the container with water up to the 10 liter (2 gal) mark.
- Set metering knob (1) to position 6.
- Start the unit (baffle removed).
- Hold the spray tube horizontally, run the engine at full throttle, spray the contents of the container down to the 5 liter (1 gal) mark and make a note of the time taken.

The SR 320 and SR 400 should spray 5 liters (1 gal) fluid within 80 to 100 seconds.

If the time required is longer, check the metering unit for contamination and clean it if necessary. Also check the carburetor setting and correct it as necessary.

If there is no noticeable improvement, please contact your STIHL dealer for assistance.

Notes on Use of Mistblowers

Comparison of principles of backpack mistblowers and backpack high-pressure sprayers

The methods of operation of low-volume mistblowers and high-pressure sprayers are fundamentally different.

In the case of the **high-pressure sprayer** the carrier liquid in the solution serves as the transport medium for the active ingredient. The solution is applied at a comparatively high pressure produced by a high-pressure pump and a small-bore nozzle. The size of the droplets formed in this process is generally in the order of 300 to 400 μm . Owing to the resultant small number of droplets, which have to wet the same crop area as in low-volume mistblowing, the active ingredients can only be applied in highly diluted form with a lot of carrier liquid.

The only way to produce smaller droplets is to considerably increase pump pressure and use much higher driving power - both these factors increase the complexity of the unit. The energy required to accelerate water is relatively high. For this reason the efficiency of high-pressure sprayers is generally low. The units themselves are quite heavy and have a short range of only 30 to 50 cm (measured from the nozzle).

In the **mistblower**, air is used as an additional transport medium for the active ingredient. An engine-powered fan produces a powerful, concentrated airstream to which the solution (active ingredient in carrier liquid) is added via a metering system. The solution is atomized into very fine droplets and discharged at high velocity by the airstream.

Depending on the design of the atomizer, it is possible to

produce droplets with a size of approx. 50 to 250 μm . The large number of fine droplets and the airstream's excellent penetration of the crop ensure high efficiency. This means that the quantity of carrier liquid (normally water) can be reduced, i. e. a higher concentration of active ingredient can be used in the solution.

Considerably less energy is required to accelerate air. Therefore, low-volume mistblowers, are more efficient (long range with relatively low driving power and low weight) and can cover a larger area per unit time.

Advantages of low-volume mistblowers over high-pressure sprayers:

- High efficiency as a result of large area coverage per unit time.
- Less physical effort - high-performance mistblowers are relatively compact and lightweight.
- High wetting capacity as a result of high kinetic energy of droplets.
- Very fine and uniform distribution of active ingredient for better biological effectiveness.
- Active ingredient is saved by reducing losses due to solution dripping from crop.
- Better adhesive properties and resistance to rain.
- No growth inhibition caused by clogging the foliage.

- Long horizontal and vertical spraying range.
- Working time is saved not only during the actual application, but also during the preparations, i.e. less spray solution has to be transported to the site and fewer re-filling stops are required.
- The formation of very fine droplets enables the concentration of active ingredient to be increased and the total amount of spray solution to be reduced - a water saving of up to 80%.

Choice of spray chemical

In the case of plant protection products preference should be given to biological products which do not harm useful insects. Local plant protection services and other experts provide information on the best type, application and concentration (mix ratio) of products.

Note: Never apply the active ingredient in concentrated form (undiluted).

Determining and mixing required quantity of solution

Step 1:

Determine the surface area to be treated in square meters (m^2). In the case of ground crops, simply multiply the length of the field by its width. The surface area of high-growing plants is calculated roughly by measuring the length of the rows and the average height of the foliage. The result is multiplied by the number of rows and then by two - if both sides have to be treated.

Step 2:

Refer to the instructions for use supplied with the active ingredient to establish the required quantity (usually quoted for 1 hectare [ha]) and the concentration (mix ratio) of the solution. Manufacturers normally quote the concentration required for high-pressure spraying. Low-volume mistblowing uses only about **one quarter** of this quantity. If the instructions for use do not contain any data for low-volume mistblowing, reduce the amount of carrier liquid (water) accordingly to suit the required concentration of active ingredient. This produces the quantity of solution required for treating 1 ha.

Step 3:

Multiply the quantity of solution required for 1 ha by the surface area determined in step 1. The result is the quantity of solution needed for the surface area to be treated.

Example:

A field with a length of 120 m and width of 30 m is to be treated with a pesticide. According to the maker's instructions, 0.6 liters are required per hectare to obtain a concentration of 0.1 % for high-pressure spraying.

A concentration of 0.1 % represents a mix ratio of 1 part pesticide to 1,000 parts water.

In this case 0.6 litres pesticide would have to be mixed with 600 litres water to make up the spray solution.

However, in low-volume mistblowing only one quarter of the water quantity is required for the same amount of pesticide. This means that the concentration used is four times higher than for high-pressure spraying. The 0.6 litres pesticide therefore have to be mixed with only 150 litres water. That is the quantity of solution required for mistblowing 1 hectare. Finally, this quantity has to be multiplied by the area to be treated in our example, i.e. 0.36 ha. The total quantity of solution to be applied to the field is 54 litres.

Calculation

Area: $120 \text{ m} \cdot 30 \text{ m} = 3,600 \text{ m}^2$
 $3,600 \text{ m}^2 : 10,000 \text{ m}^2/\text{ha} = 0.36 \text{ ha}$

Solution/ha:
 (acre): $0.6 \text{ l} : 0.001 : 4 = 150 \text{ l}$

Required quantity of solution: $150 \text{ l/ha} \cdot 0.36 \text{ ha} = 54 \text{ l}$

Note: If the area to be treated is smaller than 1 hectare, the quantity of solution required is less than the quantity of solution per hectare (acre).

Note: The increase in the strength of the mixture by a factor of 4 was assumed for the purposes of this example. Other mix ratios are possible in practical applications on the basis of empirical values, special requirements or explicit instructions.

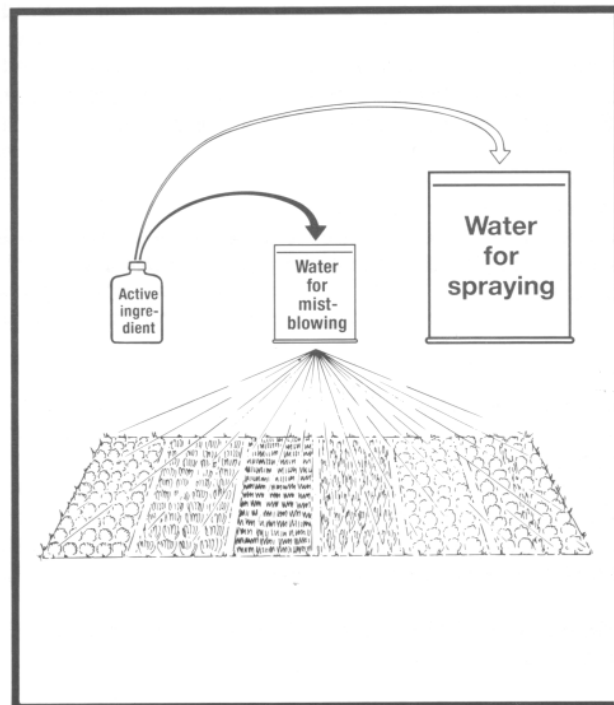

See enclosed graph 0457 352 0100

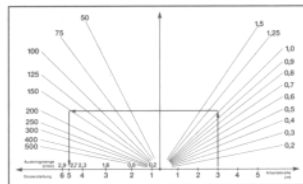

The graph makes it easier to determine the quantity of solution required. You can use a ruler and pencil to mark in your own applications.

Preparations for mistblowing

Before starting work it is necessary to determine the following points, which affect the liquid discharge rate per unit area and thus the distribution of active ingredient in the crop:

- Working width
- Walking speed
- Unit's discharge rate per unit time
- Position of spray tube (angle from horizontal)

Among other factors, the **working width** is dependent on the crop and is determined by the distance between rows of trees, shrubs and bushes. In the case of low-growing crops, the best working width is about 4 m, but can be up to 5 m if the user adjusts his walking speed accordingly. The working width should be marked with stakes to avoid any deviation.

The **walking speed** can vary greatly from user to user. For this reason it is advisable to do a trial run with the machine fueled and the container filled with water, and make a note of the time taken (stop watch). While walking, the spray tube should be operated as it will be during the real run described below.

This trial run is also used to check the working width, i.e. the greater the width, the slower the walking speed. Check the distance walked in one minute.

Rule of thumb: Normal length of stride is 0.7 to 0.9 m, but can be up to 1.0 m. Measuring the distance is better than counting the number of steps. Dividing the distance in meters by the time in minutes produces the walking speed in meters or yards per minute (m/min)

The **discharge rate per unit time** liters/min is infinitely variable on the mistblower's metering unit. The required discharge rate is determined by the area to be treated, the quantity of solution, the working width and the walking speed. It can be calculated with the aid of the following equation:

$$\frac{V_{\text{sol}} (\text{l}) \cdot V_{\text{W}} (\text{m/min}) \cdot b (\text{m})}{A (\text{m}^2)} = V_{\text{dis}} (\text{l/min})$$

Where:

V_{sol} = Quantity of solution

V_{W} = Walking speed

b = Working width

A = Area

V_{dis} = Discharge rate

Important:

All values must be inserted in the equation in the units specified. Note that hectares have to be multiplied by 10,000 to obtain square meters. Assuming a working width of 3 m and a walking speed of 60 m/min, the calculation of the above example would be as follows:

$$\frac{54 \text{ l} \cdot 60 \text{ m} \cdot 3 \text{ m}}{1 \text{ min} \cdot 3,600 \text{ m}^2} = 2.7 \text{ l/min}$$

The metering unit on the mistblower would therefore have to be set to 2.7 l/min. If this rate is not marked directly on the scale, select an intermediate setting. The settings of the metering unit and the related discharge rates are given in the mistblower's instruction manual. The following table can also be used as a rough guide for selecting discharge rates. If the required quantity of solution is not mentioned, use the next higher and lower values in the table to work out the correct proportions for your application. Similarly, the table shows the quantities of solution required per hectare (acre) at different discharge rates and working widths. They are based on a walking speed of 60 m/min.

Discharge rate (l/min)	Solution required at working width			
	1 m	2 m	3 m	4 m
0.8	133	67	44	33
1.6	267	133	89	67
2.3	383	192	128	96
2.6	433	217	144	108
2.9	483	242	161	121

In our example the quantity of solution per hectare is 150 litres and the working width 3 m. In the "3 m" column, the value 150 l is between 144 and 161 liters.

The difference between 150 and 161 is about twice as much as it is between 150 and 144. The metering unit therefore has to be set somewhere between 2.6 and 2.9. Allowing for the proportional difference, the setting should be 2.7, which corresponds to the calculated value.

The mistblower's discharge rate is also affected by the **position of the spray tube**. The discharge rates quoted above are averages for the "horizontal" and "30° up" positions. There is a noticeable reduction in discharge rate when the upward angle of the spray tube is increased, e. g. mistblowing high trees. STIHL recommends the use of a pressure pump (special accessory) for applications which require the spray tube to be held at an upward angle of more than 30°. It helps maintain a constant discharge rate in all spray tube positions.

Note

The values given in the table refer to a walking speed of 1 m/s and an area of 1 hectare.

The table is intended as a rough guide. Use the enclosed graph for special applications.

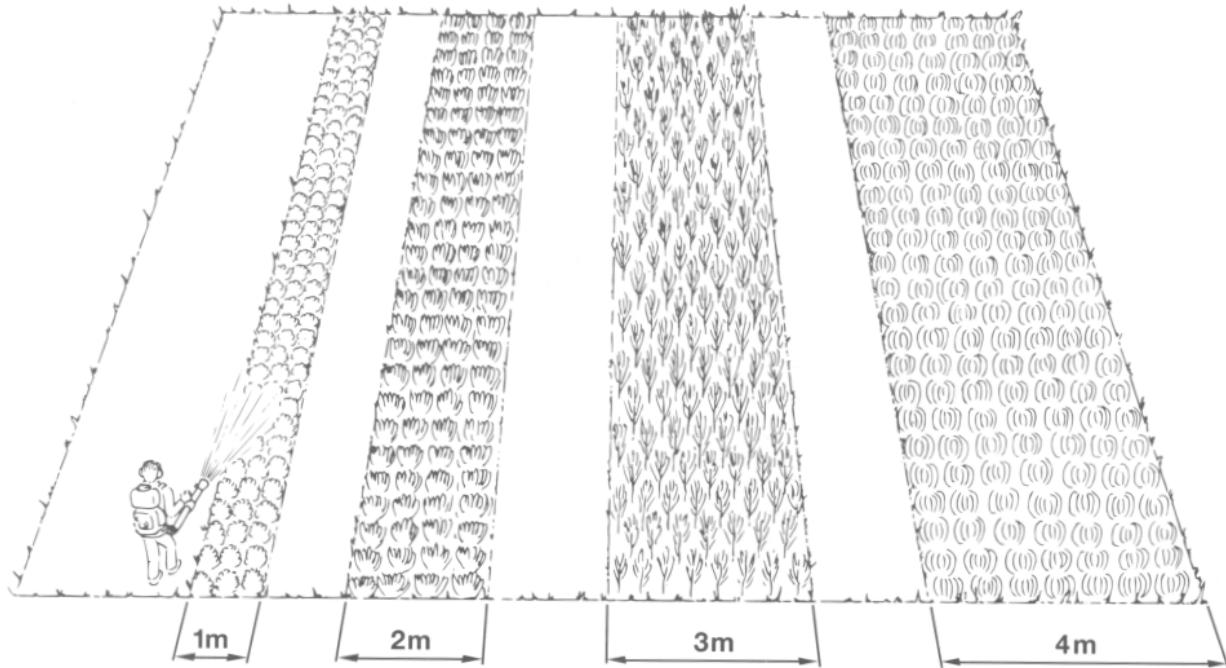

(l)	(l/min)	☼
50	0.3	1
75	0.45	1
100	0.6	1-2
125	0.75	2
150	0.9	2

(l)	(l/min)	☼
50	0.6	1-2
75	0.9	2
100	1.2	2-3
125	1.5	3
150	1.8	3-4

(l)	(l/min)	☼
50	0.9	2
75	1.35	3
100	1.8	3-4
125	2.25	4
150	2.7	5

(l)	(l/min)	☼
50	1.2	2
75	1.8	2-3
100	2.4	4
125	3	6
150	3.6	6

Use of mistblower

In mistblowing the solution flows from the container, down through the open shut-off cock and the metering nozzle to the spray tube. The jet of solution is injected into the airstream, atomized and discharged. The airstream is permeated more or less uniformly with very fine droplets.

The factors which influence the liquid discharge rate per unit area are either fixed by the setting (discharge rate per unit time) or determined by the operator. Walking speed and working width can vary. These variations can result in considerable differences in the quantity of active ingredient applied per unit area. In addition, the wetting effect can be altered by the direction and strength of the wind.

Great care must be taken with active ingredients which can harm plants and the environment if applied in too high a dosage. Too low a dosage may fail to achieve the desired effect.

To limit these variations, always run the mistblower at full throttle with the shut-off cock fully open. Accelerate the engine up to full throttle first and then open the shut-off cock. Note that the discharge rate is controlled by the metering unit, not the shut-off cock.

The normal walking speed for low-growing crops is 1 m/s. It may be necessary to walk slower when mistblowing higher crops.

To achieve greater working widths or treat open and high growing crops, the spray tube must be moved quickly back and forth or up and down. In order to extend the mistblower's vertical reach (tall trees), the spray tube must

be held steady or moved only very slowly to ensure that the spray mist is properly formed and stable.

Influence of walking speed and working width on discharge rate and amount of solution needed

Practical experience has shown that walking speed can vary by 5 to 6 m/min. A slower walking speed means that it is necessary to reduce the discharge rate or amount of solution and vice versa. Walking 6 m/min slower than the specified 60 m/min means a reduction of 10%.

In our example the setting of the metering unit would also have to be reduced by 10%, from 2.7 to 2.43 l/min. If this is not done, the quantity of solution required would increase 10%, from 54 liters to 59.4 liters.

The variation in working width can be considerable, especially if the field has not been marked with stakes. A reduction of the working width at a given walking speed means that the discharge rate would have to be reduced or the amount of solution increased and vice versa. Reducing the width by 0.5 m, after having assumed a working width of 3 meters, represents a reduction of 17%.

In our example the setting of the metering unit would have to be reduced by 17%, from 2.7 to 2.24 l/min. If this is not done, the quantity of solution required would increase 17%, from 54 liters to 63.2 liters. If both these variations occurred at the same time, the setting of the metering unit would have to be reduced by 27%, from 2.7 to 1.97 l/min, because the quantity of solution required would otherwise increase 27%, from 54 liters to 68.6 liters.

Use of standard/special accessories

Pressure pump (special accessory)

The pressure pump is recommended for applications in which the spray tube to be held at an upward angle of more than 30°. It helps maintain a constant discharge rate in all spray tube positions. Furthermore, active ingredients which tend to settle in the container are held in suspension by constant agitation of the solution.

The **tapered baffle screen** causes the solution to be discharged finely atomized in a broad, dense and short cloud.

The **deflector baffle screen** diverts the spray jet at an angle. It can be used for under-leaf treatment of low-growing crops.

The **dual deflector baffle screen** splits the spray jet into two and thus allows two rows of plants to be treated simultaneously.

Top: Tapered baffle screen
Center: Deflector baffle screen
Bottom: Dual deflector baffle screen

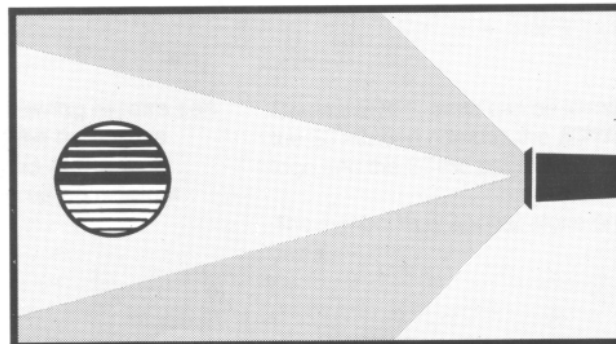
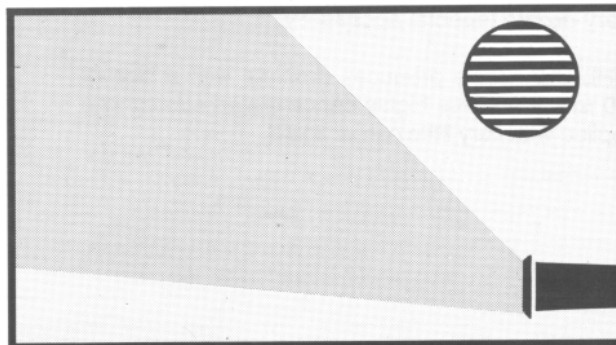
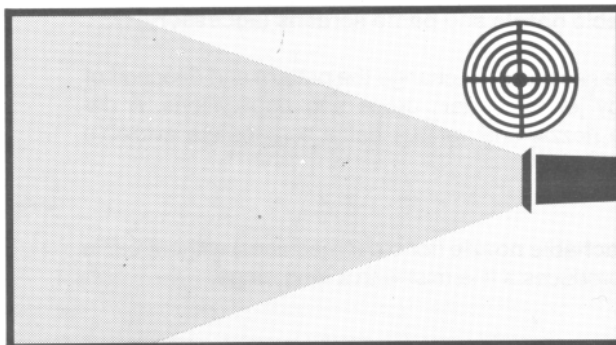

Detachable nozzle and baffle screens (accessory)

It may be necessary to change the pattern and direction of the spray jet for certain crops and applications. A detachable nozzle and various baffle screens are available for this purpose.

The **detachable nozzle** (for older machines) without baffle screen produces a fine mist with a long range.

ULV rotary nozzle (special accessory)

The STIHL ULV nozzle produces droplets with a size of about 50 μm . It enables highly concentrated substances to be applied with very little carrier liquid.

Some important conversion factors

1 m	=	1,094	yd
1 m	=	39,370	in
1 yd	=	0,914	m
1 yd	=	3	ft
1 ft	=	12	in
1 m/s	=	3,28	ft/s
1 ft/s	=	0,305	m/s
1 ha	=	2,470	acre
1 acre	=	0,405	ha
1 ar	=	0,025	acre
1 acre	=	4840	yd
1 l	=	0,264	US gal
1 l	=	2,11	US pt
1 l	=	33,81	fl.oz
1 US gal	=	3,785	l
1 US gal	=	8	US pt
1 US gal	=	128	fl.oz
l/min	=	0,264	GPM
1 GPM	=	3,785	l/min

Maintenance Chart

Please note that the following maintenance intervals apply for normal operating conditions only. If your daily working time is longer than normal or operating conditions are difficult (very dusty work area) shorten the specified intervals accordingly.		before starting work	after finishing work or daily	after each refueling stop	weekly	monthly	if faulty	if damaged	as required	see page:
Complete machine	Visual inspection (condition, leaks)	x		x						
	Clean		x							
Control handle	Check operation	x		x						13
Air filter	Clean								x	19
	Replace							x		19
Filter in fuel tank	Check						x			15
	Replace felt and strainer								x	15
Fuel tank	Clean					x				15
Carburetor	Check idle adjustment	x		x						20
	Idle setting								x	20
Spark plug	Readjust electrode gap						x			22
Cylinder fins	Clean				x					
Spark arresting screen	Inspect					x				
	Clean or replace							x		
All accessible screws and nuts (not adjusting screws)	Retighten								x	
Container with line	Visual inspection	x								
Metering unit	Check						x			27
Rubber vibration buffers	Visual inspection	x								
	To be replaced only by STIHL dealer						x	x		

The user of this unit should carry out only the maintenance operations described in this manual. Other repair work may be performed only by an authorized STIHL Service dealer.

Warranty claims following repairs can be accepted only if the repair has been performed by an authorized STIHL Service dealer using original STIHL spare parts.

Original STIHL parts can be identified by the STIHL part number, the **STIHL** logo and the STIHL parts symbol . The symbol may appear alone on small parts.

Specifications

Engine

STIHL single cylinder two-stroke engine

	SR 320	SR 400
Displacement:	44.9 cm ³ (2.74 cu.in)	56.5 cm ³ (3.45 cu.in)
Bore:	41 mm (1.61 in)	46 mm (1.81 in)
Stroke:	34 mm (1.34 in)	34 mm (1.34 in)
Engine power:	2,0 kW	2,5 kW
For US only:	320 L	
Bystander noise per ANSI B 175.2 -1990	70 dB (A)	

Ignition System

Type:	Electronic magneto ignition (breakerless)
Spark plug (suppressed):	NGK BPMR 7 A or Bosch WSR 6 F Heat range 200 Electrode gap 0.5 mm (0.02 in)
Spark plug thread:	M 14x1.25; 9.5 mm (0.37 in) long

Fuel System

Carburetor:	All position diaphragm carburetor with integral fuel pump
Air filter:	Foam filter
Fuel tank capacity:	1.5 l (3.2 US pt)
Fuel mixture:	see chapter "Fuel"

Spraying and Spreading Attachment

Model	Airflow rate/hour	Air velocity	Engine speed
SR 320	655 m ³ /h (385 cfm)	92 m/s (302 ft/s)	6,900 rpm
SR 400	715 m ³ (420 cfm)	101 m/s (330 ft/s)	7,500 rpm
Container capacity:	13 L (3.5 US gal)		
Size of filler strainer mesh (SR):	1 mm (3/64")		
Rate of liquid discharge (SR) without screen:	0.13 - 2.78 L/min (0.27 - 5.8 pt/min)		
with screen:	0.14 - 3.03 L/min (0.29 - 6.4 pt/min) (infinitely variable)		
Quantity remaining in container (SR):	0.1 L (3 1/2 fl. oz) (design related)		

Spraying range

	SR 320	SR 400
Horizontal	10.0 m (33 ft)	12.0 m (40 ft)
Vertical	9.5 m (31 ft)	11.5 m (38 ft)

Dimensions

	SR 320, SR 400
Height:	625 mm (24.6 in)
Width:	480 mm (18.9 in)
Depth:	280 mm (11.0 in)

Special Accessories

Pressure pump mounting kit, Mistblower conversion kit
Vacuum attachment, Spreading attachment

Back padding, Lap belt

Weights (dry)

SR 320/400:	10.9 kg (24.0 lb)
-------------	-------------------

STIHL Incorporated Federal Emission Control Warranty Statement

Your Warranty Rights and Obligations

The U.S. Environmental Protection Agency (EPA) and STIHL Incorporated are pleased to explain the Emission Control System Warranty on your equipment type engine. In the U.S. new 1997 and later model year small off-road equipment engines must be designed, built and equipped, at the time of sale, to meet the U.S. EPA regulations for small non road engines. The equipment engine must be free from defects in materials and workmanship which cause it to fail to conform with U.S. EPA standards for the first two years of engine use from the date of sale to the ultimate purchaser.

STIHL Incorporated must warrant the emission control system on your small off-road engine for the period of time listed below provided there has been no abuse, neglect or improper maintenance of your small off-road equipment engine.

Your emission control system includes parts such as the carburetor and the ignition system. Also included may be hoses, and connectors and other emission related assemblies.

Where a warrantable condition exists, STIHL Incorporated will repair your small off-road equipment engine at no cost to

you, including diagnosis (if the diagnostic work is performed at an authorized dealer), parts, and labor.

Manufacturer's Warranty Coverage:

In the U.S., 1997 and later model year small off-road equipment engines are warranted for two years. If any emission-related part on your engine is defective, the part will be repaired or replaced by STIHL Incorporated free of charge.

Owner's Warranty Responsibilities:

As the small off-road equipment engine owner, you are responsible for the performance of the required maintenance listed in your owner's manual. STIHL Incorporated recommends that you retain all receipts covering maintenance on your small off-road equipment engine, but STIHL Incorporated cannot deny warranty solely for the lack of receipts or for your failure to ensure the performance of all scheduled maintenance.

Any replacement part or service that is equivalent in performance and durability may be used in non-warranty maintenance or repairs, and shall not reduce the warranty obligations of the engine manufacturer.

As the small off-road equipment engine owner, you should be aware, however, that STIHL Incorporated may deny you warranty coverage if your small off-road equipment engine or a part has failed due to abuse, neglect, improper maintenance or unapproved modifications.

You are responsible for presenting your small off-road equipment engine to a STIHL service center as soon as a problem exists. The warranty repairs will be completed in a reasonable amount of time, not to exceed 30 days.

If you have any questions regarding your warranty rights and responsibilities, please contact a STIHL customer service representative at 1-800-467-8445 or you can write to

STIHL Inc.,
536 Viking Drive, P.O. Box 2015,
Virginia Beach, VA 23450-2015.

Coverage by STIHL Incorporated

STIHL Incorporated warrants to the ultimate purchaser and each subsequent purchaser that your small off-road equipment engine will be designed, built and equipped, at the time of sale, to meet all applicable regulations. STIHL Incorporated also warrants to the initial purchaser and each subsequent

purchaser that your engine is free from defects in materials and workmanship which cause the engine to fail to conform with applicable regulations for a period of two years.

Warranty Period

The warranty period will begin on the date the utility equipment engine is purchased by the initial purchaser and you have signed and sent back the warranty card to STIHL. If any emission related part on your engine is defective, the part will be replaced by STIHL Incorporated at no cost to the owner. Any warranted part which is not scheduled for replacement as required maintenance, or which is scheduled only for regular inspection to the effect of "repair or replace as necessary" will be warranted for the warranty period. Any warranted part which is scheduled for replacement as required maintenance will be warranted for the period of time up to the first scheduled replacement point for that part.

Diagnosis

You, as the owner, shall not be charged for diagnostic labor which leads to the determination that a warranted part is defective. However, if you claim warranty for a component and the machine is tested as non-defective, STIHL Incorporated will charge you for the cost of the emission test.

Mechanical diagnostic work will be performed at an authorized STIHL servicing dealer. Emission test may be performed either at STIHL Incorporated or at any independent test laboratory.

Warranty Work

STIHL Incorporated shall remedy warranty defects at any authorized STIHL servicing dealer or warranty station. Any such work shall be free of charge to the owner if it is determined that a warranted part is defective. Any manufacturer-approved or equivalent replacement part may be used for any warranty maintenance or repairs on emission-related parts and must be provided without charge to the owner. STIHL Incorporated is liable for damages to other engine components caused by the failure of a warranted part still under warranty.

The following list specifically defines the emission-related warranted parts:

Carburetor
Choke (Cold start enrichment system)
Intake manifold
Air filter
Spark plug
Magneto or electronic ignition system (ignition module)
Catalytic converter (if applicable)
Fasteners

Where to make a claim for Warranty Service

Bring the product to any authorized STIHL servicing dealer and present the signed warranty card.

Maintenance Requirements

The maintenance instructions in this manual are based on the application of the recommended 2-stroke fuel-oil mixture (see also instruction "Fuel"). Deviations from this recommendation regarding quality and mixing ratio of fuel and oil may require shorter maintenance intervals.

Limitations

This Emission Control Systems Warranty shall not cover any of the following:

- repair or replacement required because of misuse, neglect or lack of required maintenance,
 - repairs improperly performed or replacements not conforming to STIHL Incorporated specifications that adversely affect performance and/or durability, and alterations or modifications not recommended or approved in writing by STIHL Incorporated,
- and
- replacement of parts and other services and adjustments necessary for required maintenance at and after the first scheduled replacement point.

Solution is produced by mixing the amount of active ingredient determined in calculation 1 (216 g) with the quantity of water in calculation 2 (54 l).

The graph can be used to check whether the selected walking speed and working width correspond to a metering setting. If not, either reduce quantity of water or increase walking speed.

Walking speed (m/s)

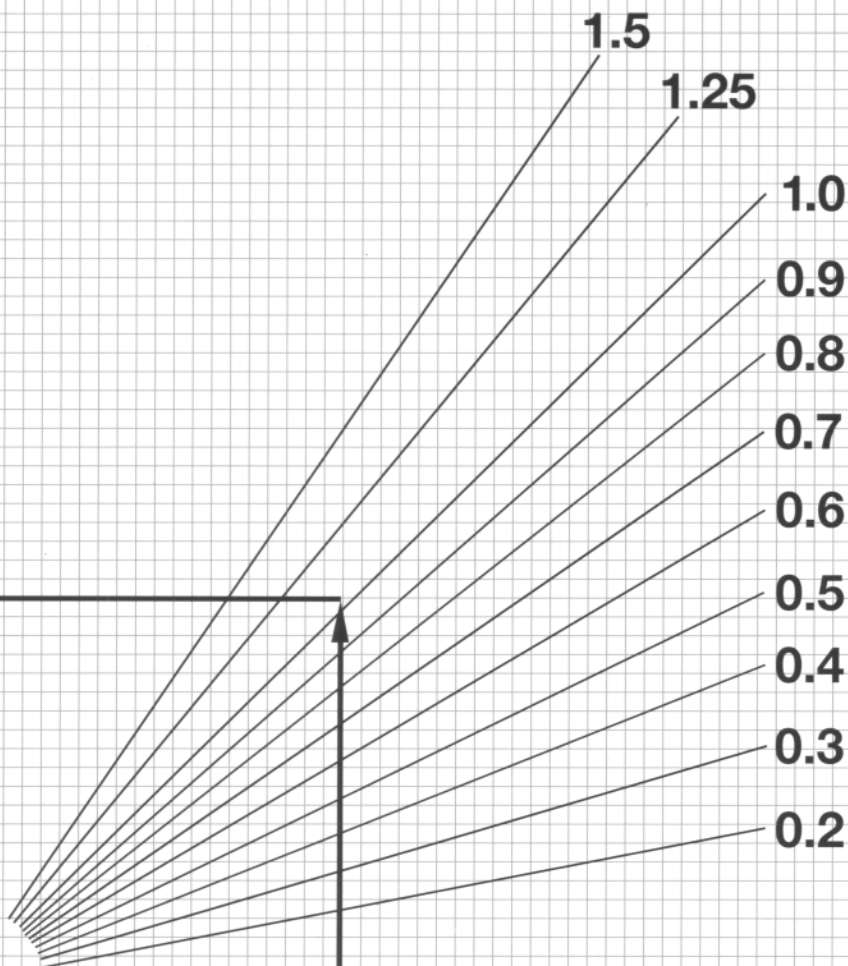

Some important conversion factors

1 m	=	1,094	yd
1 m	=	39,370	in
1 yd	=	0,914	m
1 yd	=	3	ft
1 ft	=	12	in
1 m/s	=	3,28	ft/s
1 ft/s	=	0,305	m/s
1 ha	=	2,470	acre
1 acre	=	0,405	ha
1 ar	=	0,025	acre
1 acre	=	4840	yd ²
1 l	=	0,264	US gal
1 l	=	2,11	US pt
1 l	=	33,81	fl.oz
1 US gal	=	3,785	l
1 US gal	=	8	US pt
1 US gal	=	128	fl.oz
1 l/min	=	0,264	GPM
1 GPM	=	3,785	l/min



WARNING!

The engine exhaust from this product contains chemicals known to the State of California to cause cancer, birth defects or other reproductive harm.

0458 352 3021

englisch/englisch USA/CARB/EPA