

STIHL FG 3

Dear Customer!

- D** Gebrauchsanleitung
- GB** Instruction Manual
- F** Notice d'emploi
- E** Instrucciones de servicio
- I** Istruzioni per l'uso
- P** Instruções de serviço

Hans Peter Lind
Hans Peter Lind

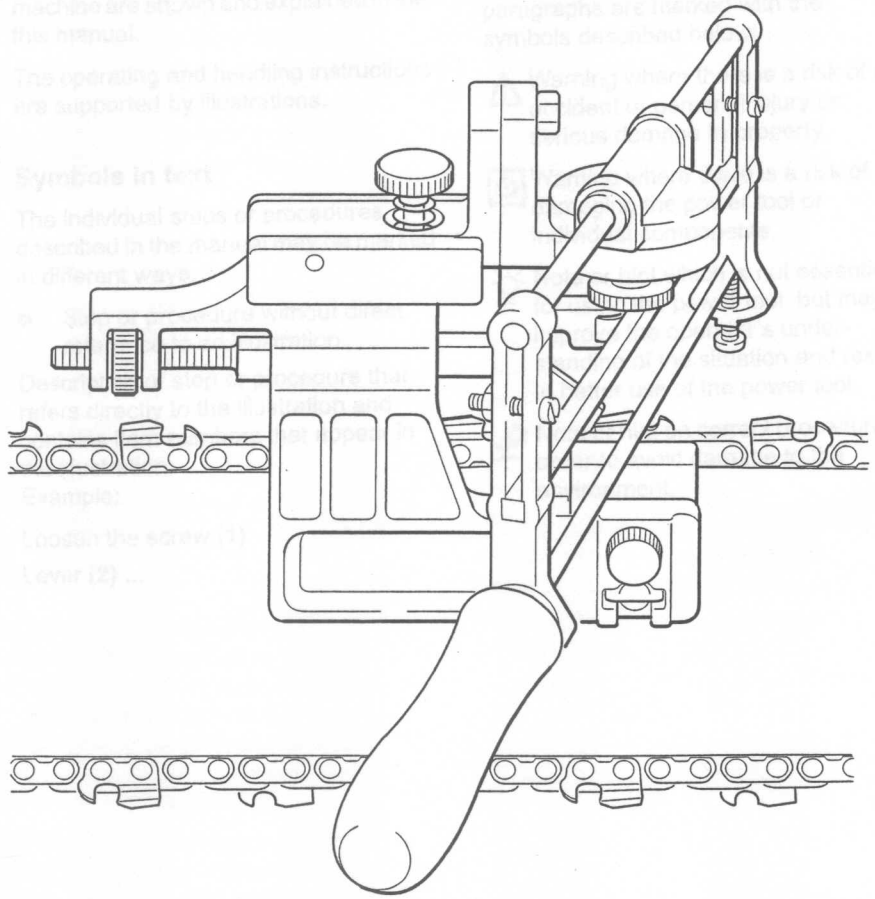

STIHL Power Tools, Inc. • 2001 • 2002 • 2003 • 2004 • 2005 • 2006 • 2007 • 2008 • 2009 • 2010 • 2011 • 2012 • 2013 • 2014 • 2015 • 2016 • 2017 • 2018 • 2019 • 2020 • 2021 • 2022 • 2023 • 2024 • 2025

Guide to Using this Manual

Dear Customer,

Thank you for choosing a quality engineered STIHL product.

This machine has been built using modern production techniques and comprehensive quality assurance. Every effort has been made to ensure your satisfaction and troublefree use of the machine.

Please contact your dealer or our sales company if you have any queries concerning your machine.



Hans Peter Stihl

Pictograms

All the pictograms attached to the machine are shown and explained in the this manual.

The operating and handling instructions are supported by illustrations.

Symbols in text

The individual steps or procedures described in the manual may be marked in different ways:

- Step or procedure without direct reference to an illustration.





Description of step or procedure that refers directly to the illustration and contains item numbers that appear in the illustration.

Example:

Loosen the screw **(1)**

Lever **(2)** ...

In addition to the operating instructions, this manual may contain paragraphs that require your special attention. Such paragraphs are marked with the symbols described below:

-  Warning where there is a risk of an accident or personal injury or serious damage to property.
-  Warning where there is a risk of damaging the power tool or individual components.
-  Note or hint which is not essential for using the power tool, but may improve the operator's understanding of the situation and result in better use of the power tool.
-  Note or hint on correct procedure in order to avoid damage to the environment.

Safety Precautions

Application

✱ Equipment and features

This instruction manual refers to several models with different features. Components that are not installed in all models and related applications are marked thus * . Such components are available as special accessories from your STIHL dealer.

Engineering improvements

STIHL's philosophy is to continually improve all of its products. As a result, engineering changes and improvements are made from time to time. If the operating characteristics or the appearance of your machine differ from those described in this manual, please contact your STIHL dealer for assistance.



To reduce the risk of personal injury, special safety precautions must be observed while operating the filing tool.



Read the operating instructions carefully and keep them in a safe place for later reference.

Always shut off the saw engine before working with the filing tool:
Move Master Control lever / slide control or the separate stop switch to **STOP** or **0**.

Electric saws: Disconnect plug from power supply.



Wear gloves.

It is absolutely essential to comply with the angles and dimensions specified in these instructions. If the **saw chain is incorrectly sharpened** – and in particular if the depth gauges are set too low – there is a risk of increased saw kickback and **personal injury**.

Observing the safety precautions and specifications in these instructions and the owner's manual of the saw model on which the filing tool is mounted can help reduce the risk of injury and damage to the saw.

The STIHL filing tool can be used to sharpen all STIHL Oilomatic saw chains with the exception of square ground chains (RSL, RSLF, RSLH) and carbide-tipped chains (RD, RDS). Sharpening is effected with the guide bar and chain mounted on the saw.

For accurate results it is best to clamp the guide bar in a bench vise or, at the cutting site, in the STIHL bar vise (special accessory).

File correctly

- Sharpen the chain frequently, take away as little metal as possible – two or three strokes of the file are usually enough.
- Always file from the inside to the outside of the cutter.
- The file only sharpens on the forward stroke – lift the file off the cutter on the backstroke.
- Avoid touching the tie straps and drive links with the file.

Setting Up

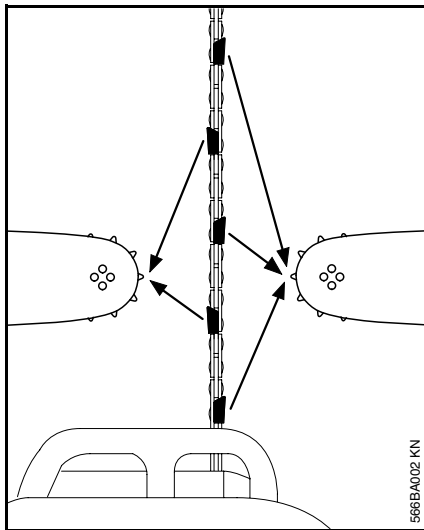

Use a slide caliper or similar to find the shortest cutter. This is the master cutter for filing all other cutters.

If the master cutter is in the left-hand row of cutters, clamp the guide bar so that the bar nose points to the right. If the master cutter is in the right-hand row of cutters, the bar nose must point to the left.

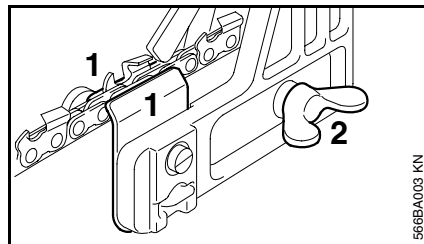

- Place the filing tool on the guide bar.
- The clamping jaws (1) must face the bar nose and be in line with top edge of rivet heads.
- Tighten down the wing screw (2).

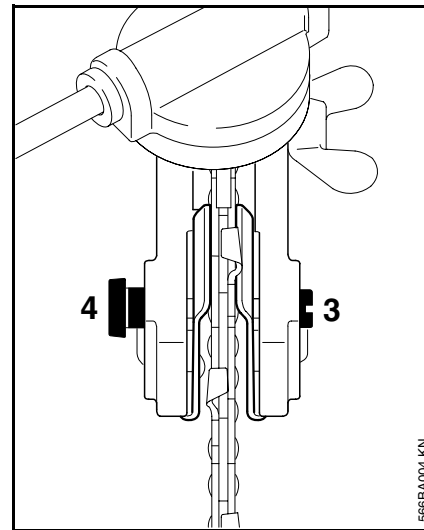

- Use the adjusting screw (3) to center the filing tool above the chain.
- Tighten the second clamping jaw with the clamp screw (4) so that the chain can still be pulled along the bar with a screwdriver or suitable rod engaged in a cutter.

Adjustments

Chain Type	Filing Angle
Rapid Micro (RM)	30°
Rapid Super (RS)	30°
Picco Micro (PM/PMN)	30°
RCX, RMX, PMX (ripping chain)	10°

Chain Pitch		File Diameter	
inch	(mm)	mm	(inch)
1/4	(6,35)	4,0	(5/32)
3/8 PMN	(9,32)	4,0	(5/32)
3/8 P	(9,32)	4,0	(5/32)
0.325	(8,25)	4,8	(3/16)
3/8	(9,32)	5,2	(13/64)
0.404	(10,26)	5,5	(7/32)

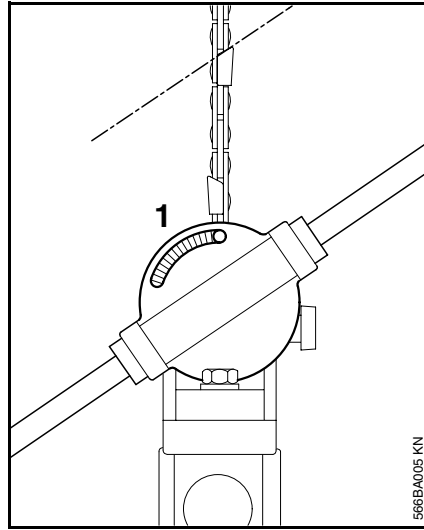

1 = Set the filing angle

💡 - One notch on clamp is equivalent to 5°.

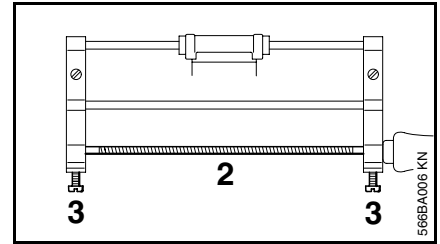

- Fit the specified chain sharpening file (**2**) in the two holders on the filing tool and secure in position with the screws (**3**).

💡 Use only special saw chain sharpening files. Other files are unsuitable for sharpening chains because they have the wrong shape and cut.

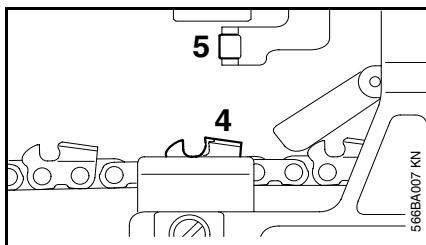

- Move top plate of master cutter (4) so that it is approximately under the center of the stop roller (5).

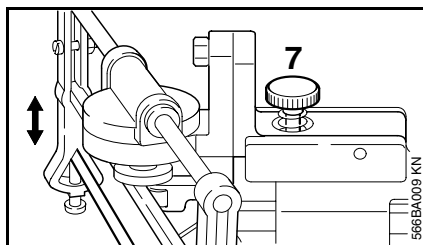

- Rotate height adjusting screw (7) (counterclockwise to lower file – clockwise to raise file) until 1/10 of file diameter projects above top plate.

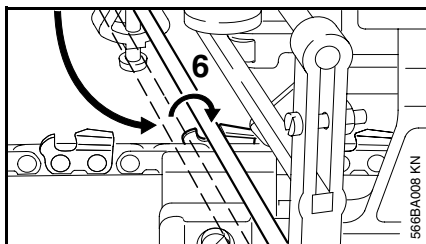

- Position the file (6) between the side plate and depth gauge of the master cutter by swinging and lifting the filing frame.

Sharpening

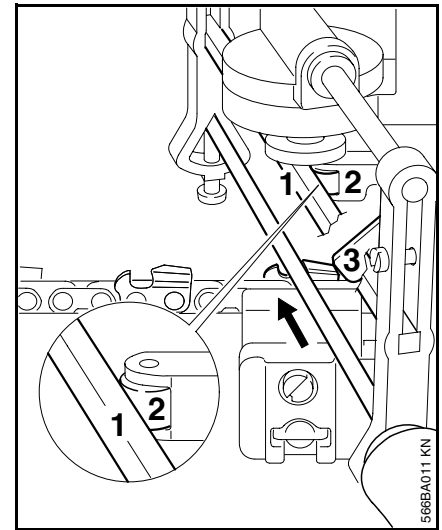
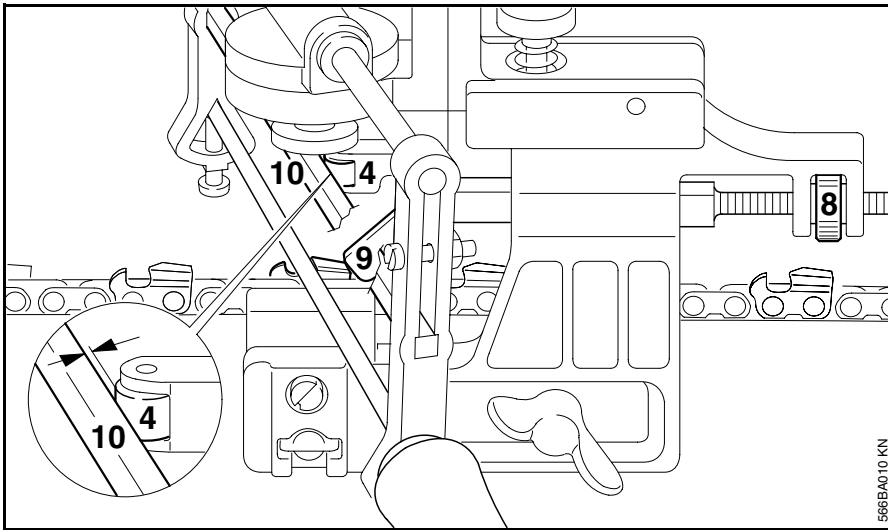

- Rotate the knurled nut **(8)** to move stop **(9)** up against the back of the cutter to be sharpened.
- Now rotate the knurled nut a little more until the side plate presses against the file and the stop bar **(10)** is lifted about 0.1 to 0.2 mm off the stop roller **(4)**.
- Sharpen the master cutter with 2 to 3 firm strokes of the file. Always file from the inside to the outside of the side plate.
- The stop bar **(1)** should now locate against the stop roller **(2)**. If this is not the case, readjust the stop **(3)** slightly and pull the chain up against it. Check the position of the stop again.

Use the setting for the master cutter to sharpen all the other cutters in the row.

Second row of cutters

After sharpening all the cutters in the first row, reset the filing tool to sharpen the second row as described in chapter "Adjustments".

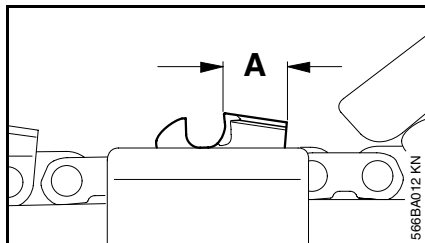

After sharpening the first cutter in the second row:

- Check the cutter length (**A**).

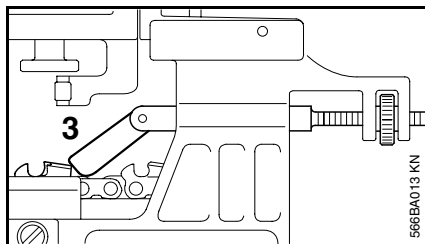

- If it differs from the length of the master cutter, change the position of the stop (**3**), resharpen and check again.
- If the length is correct, sharpen all cutters in the second row using this setting.

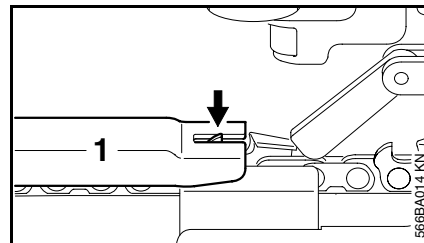

Depth gauges

Chain Pitch inch	(mm)	Filing Gauge Part No.
$\frac{1}{4}$	(6,35)	1110 893 4000
$\frac{3}{8}$ PMN	(9,32)	0000 893 4000
$\frac{3}{8}$ P	(9,32)	1110 893 4000
0.325	(8,25)	1110 893 4000
$\frac{3}{8}$	(9,32)	1110 893 4000
0.404	(10,26)	1106 893 4000

- Place the appropriate filing gauge (**1**) (special accessory) on the chain. If the depth gauge projects above the filing gauge, it has to be lowered.

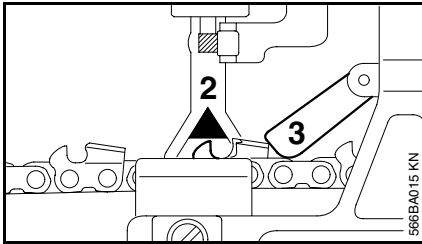

- Remove round file and fit the triangular file **(2)** 0811 421 8971 in its place.
- Set filing angle to 0° .
- Pull chain along bar until the depth gauge is under the file.
- Adjust stop **(3)** until it butts against the back of the cutter.

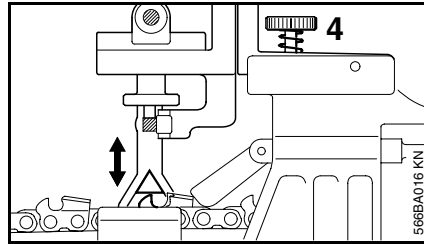

- Rotate height adjusting screw **(4)** so that the depth gauge is filed back to the required height (flush with gauge). Then remove the filing gauge and file down all depth gauges to the same setting.

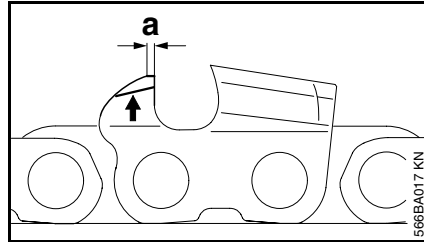

- Finish off by filing the slope by hand, parallel to the stamped marking, until dimension “**a**” is approx. 0.5 mm.

Main Parts

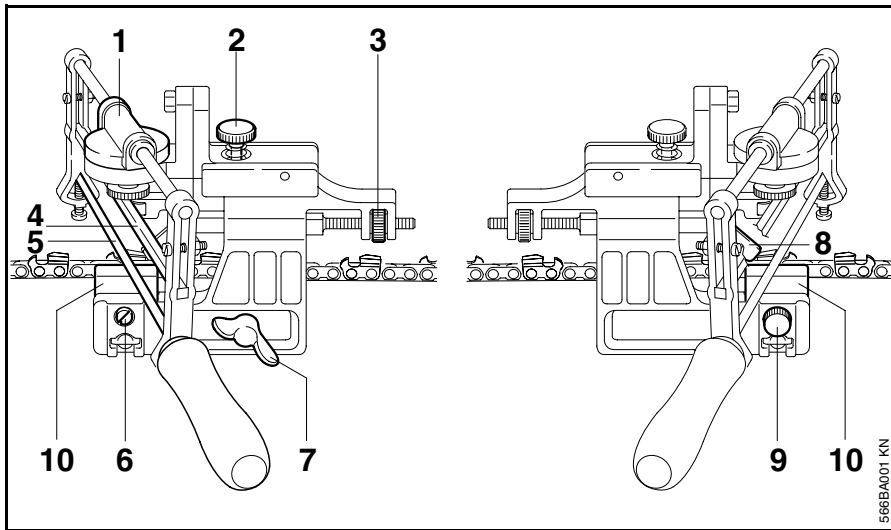

- 1 Guide
- 2 Height adjusting screw
- 3 Lateral adjusting screw
- 4 Stop bar
- 5 Sharpening file
- 6 Adjusting screw
- 7 Wing screw
- 8 Stop
- 9 Clamp screw
- 10 Clamping jaws