

STIHL®

STIHL HOS

Instruction Manual



Contents

Guide to Using this Manual	2
Safety Precautions	3
Applications	4
Assembling the Sharpener	4
Mounting the Grinding Wheel	6
Test Run	7
Mounting the Swivelling Tool Rest	7
Chains with 1.3 mm (0.05")	
Drive Link Gauge	8
Preparations for Sharpening	9
Sharpening Procedure	12
Lowering Depth Gauges	14
Dressing the Grinding Wheel	16
Maintenance Chart	17
Minimize Wear and	
Avoid Damage	18
Main Parts of Sharpener	19
Specifications	19
Special Accessories	20
Maintenance and Repairs	20
Certificate of Conformity	21
Quality Certification	22

Dear Customer,

Thank you for choosing a quality engineered STIHL product.

This machine has been built using modern production techniques and comprehensive quality assurance. Every effort has been made to ensure your satisfaction and troublefree use of the machine.

Please contact your dealer or our sales company if you have any queries concerning your machine.



Hans Peter Stihl



HOS

Guide to Using this Manual

Pictograms

All the pictograms attached to the machine are shown and explained in this manual.

The operating and handling instructions are supported by illustrations.

Symbols in text

The individual steps or procedures described in the manual may be marked in different ways:

- A bullit marks a step or procedure without direct reference to an illustration.

A description of a step or procedure that refers directly to an illustration may contain item numbers that appear in the illustration.

Example:

Loosen the screw (1)

Lever (2) ...

In addition to the operating instructions, this manual may contain paragraphs that require your special attention. Such paragraphs are marked with the symbols described below:



Warning where there is a risk of an accident or personal injury or serious damage to property.



Caution where there is a risk of damaging the machine or its individual components.



Note or hint which is not essential for using the machine, but may improve the operator's understanding of the situation and result in better use of the machine.



Note or hint on correct procedure in order to avoid damage to the environment.

* Equipment and features

This instruction manual may refer to several models with different features. Components that are not installed on all models and related applications are marked with an asterisk (*). Such components may be available as special accessories from your STIHL dealer.

Engineering improvements

STIHL's philosophy is to continually improve all of its products. As a result, engineering changes and improvements are made from time to time. If the operating characteristics or the appearance of your machine differ from those described in this manual, please contact your STIHL dealer for assistance.

Therefore some changes, modifications and improvements may not be covered in this manual.

Safety Precautions



Additional safety precautions have to be observed when operating the universal sharpener.



It is important that you read and understand the owner's manual before using your tool for the first time. Keep it in a safe place for later reference.

Non-observance of the following safety precautions may cause serious or even fatal injury.

Always observe local safety regulations, standards and ordinances.

If you have never used this sharpener model before:

Have your dealer or a trained expert show you how to operate it properly and safely.

Minors should never be allowed to use an electric sharpener.

Keep children, bystanders and animals well clear of the work area.

Only use the grinding wheels supplied by STIHL or expressly approved by STIHL for use with your specific model.

Do not use any other grinding wheels since they will increase the risk of injury.

Switch on the motor only if its operating voltage agrees with the voltage of your power supply.

Clothing and Equipment

Wear proper protective clothing and equipment.

The grinding dust produced when using this sharpener may cause health problems. Always use a dust **extractor** or wear a suitable **respirator**.

The sparks created during sharpening may cause eye injuries.



Always wear **safety glasses**.

Clothing must be sturdy and snug-fitting, but allow complete freedom of movement.

Wear overalls – avoid loose-fitting jackets.



Wear steel-toed **safety boots** with non-slip soles.



Wear **heavy-duty, non-slip gloves**, preferably made of leather.

Before Starting Work

Check that your sharpener is properly assembled and in good condition. Do not operate your sharpener with a damaged connecting cord or grinding wheel.

Maintenance and Repairs

Always disconnect the unit from the power supply before carrying out any maintenance work. Only perform the adjustments and maintenance operations described in this manual.

All other maintenance and repairs should be carried out by your STIHL dealer.

Only use original STIHL replacement parts.

In the interests of your own safety, never modify your electric sharpener in any way.

Applications

The STIHL HOS sharpens all STIHL Oilomatic saw chains with the exception of carbide-tipped chains (RD, RDS).

All the necessary setting data and grinding wheels are listed in the instruction sheet 0457 717 0000.

Assembling the Sharpener

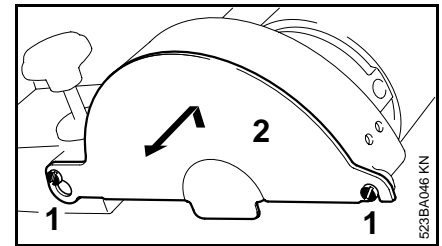
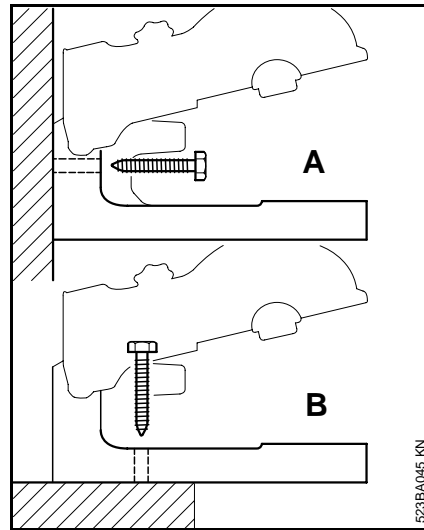

- Loosen the M5x10 screws (1) and lift the guard plate (2) away.

If you mount the unit on a bench, note that the chain must hang freely in all swivelling tool rest positions.

Secure the HOS base with screws.

A = For wall mounting, use two suitable 8.0 mm dia. screws (e.g. 8 mm x 100 mm wood screws, DIN 571-St), 8.4 mm dia. washers and matching wall plugs (e.g. 10x50 mm plastic wall plugs).

B = For bench mounting, use two suitable 8.0 mm dia. screws (e.g. 8 mm x 100 mm wood screws, DIN 571-St), 8.4 mm dia. washers.

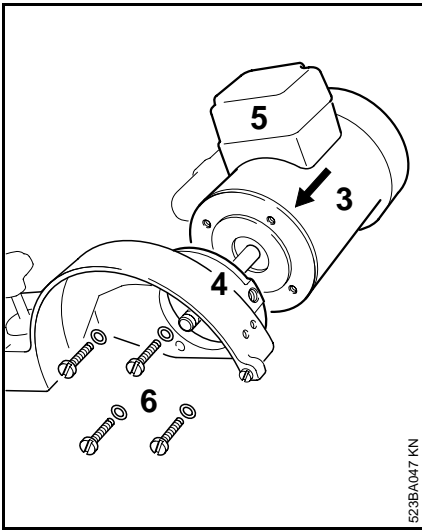

523BA047 KN

- Fit motor (3) on motor arm (4). The switchbox (5) must face up.
- Insert the four M5x22 pan head screws (6) and tighten them down firmly in a diagonal pattern.

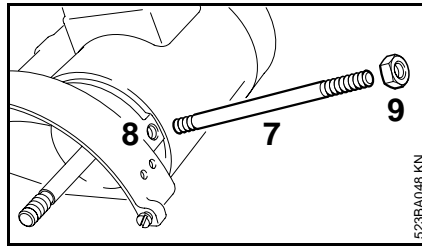

523BA048 KN

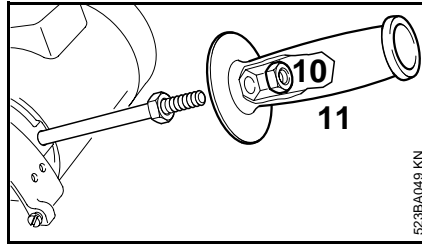

523BA049 KN

- Screw short threaded end of M10x145 stud (7) into housing bore (8).
- Screw M10 nut (9) on to other end of stud.

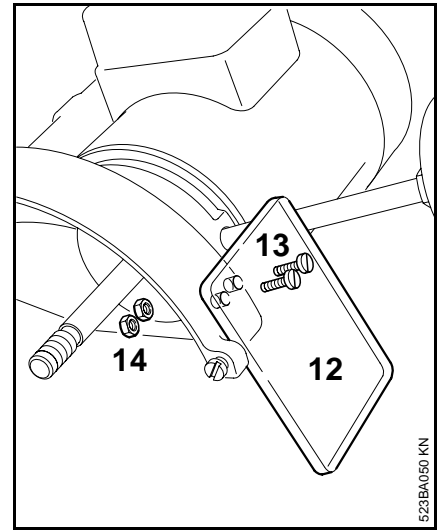

523BA050 KN

- Place transparent shield (12) against the guard and line up the holes.
- Insert M4x12 screws (13) in the holes and fit the M4 nuts (14).
- Tighten down the screws firmly.
- Refit the guard plate.

Mounting the Grinding Wheel

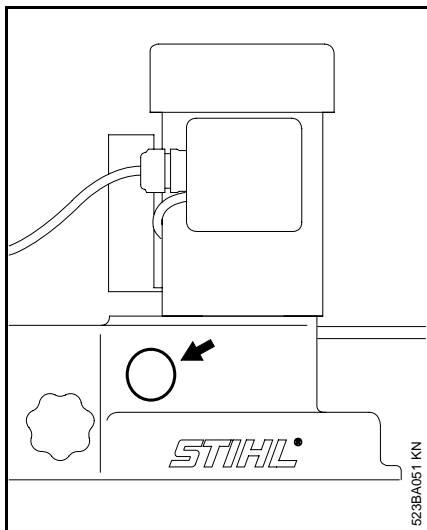

Work Light*

- Use a punch to pierce the casting skin and clean up the edges with a round file.
- Position lamp socket in opening from outside and secure it with screw ring.

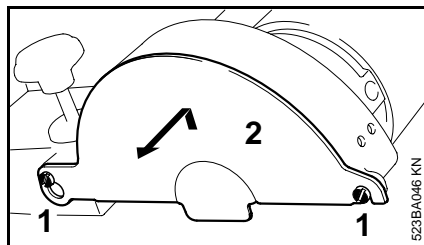

- ⚠ Always check condition of grinding wheels by performing ringing test before mounting. Never use damaged grinding wheels.
- Loosen the M5x10 screws (1), then lift and remove the guard plate (2).

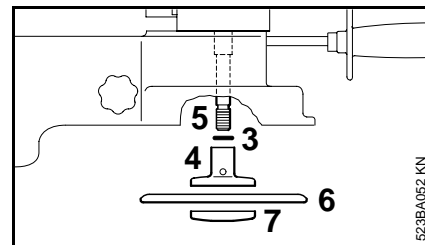

- Fit the O-ring (3) in the spacer (4). Push the onto the motor shaft (5) (spacer flange must face away from motor).
- Fit the required grinding wheel (6) – see instruction sheet or "Special Accessories" – with its rounded side facing the motor
- Fit the thrust washer (7) on the shaft with its raised side facing away from motor.

* see "Guide to Using this Manual"

Test Run

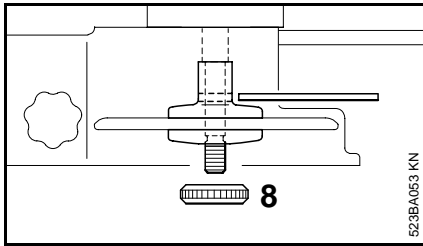

- Line up the cross holes in the spacer and motor shaft and insert the locking pin.
- Tighten down the grinding wheel with the knurled nut (8) – left-hand thread.
- Remove the locking pin.
- Refit the guard plate.

Every time you mount a grinding wheel:

- Cord off the general work area (danger zone).
- Run grinding wheel at maximum permissible speed for at least one minute.

Mounting the Swivelling Tool Rest

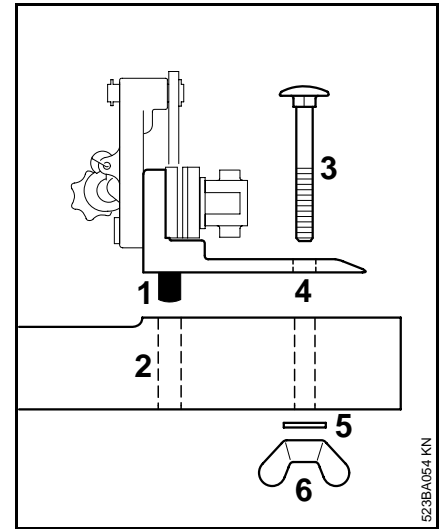

- Engage pin (1) on underside of swivelling tool rest in hole (2) in sharpener's base.
- Insert M8 x 60 round head square neck bolt (3) through the slot (4).
- Fit the washer (5) and tighten moderately with the M8 wingnut (6).

Chains with 1.3 mm (0.05") Drive Link Gauge

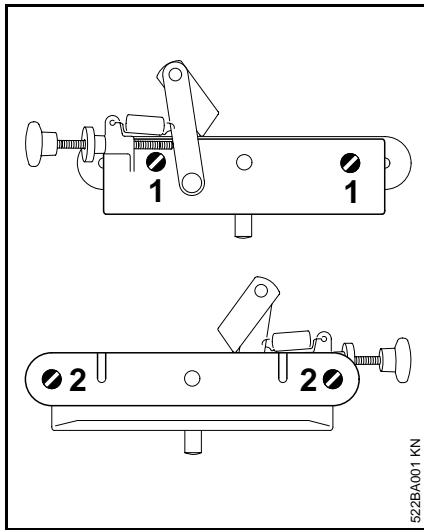

- Unscrew the clamping lever and remove it together with the thrust pad.
- Remove the two M6x8 pan head screws (1) from the swivelling tool rest.
- Remove the two M6x8 pan head screws (2) from the guide rail.

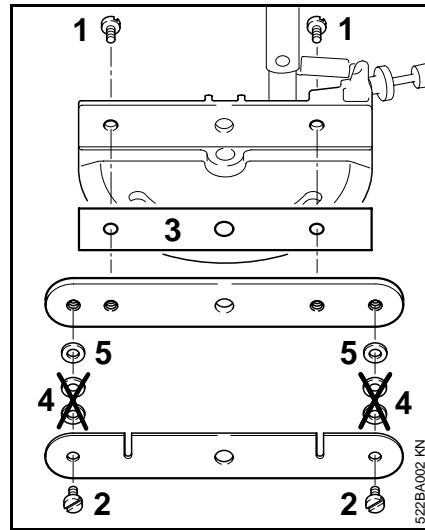

- Position 0.15 mm (0.006") shim (3) for chain with 1.3 mm (0.05") drive links between the guide rail and swivelling tool rest.
- Insert the two M6x8 pan head screws (1) through the back of the swivelling tool rest and screw them into the guide rail.
- Fit one 1.3 mm (0.05") washer (5) in place of the two 0.9 mm (0.035") washers (4) between the clamping rail and guide rail in each case.
- Insert the two M6x8 pan head screws (2) through the clamping rail and screw them into the guide rail.

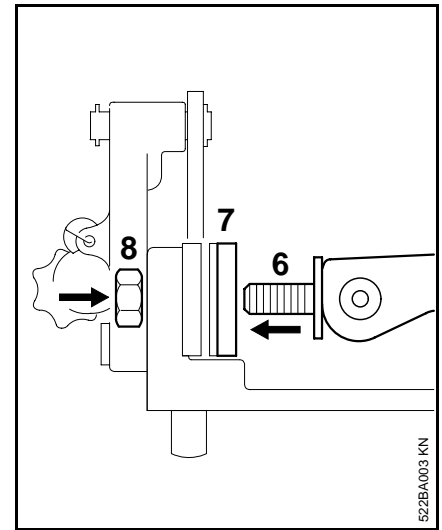

- Push clamping lever's screw (6) through the center hole in the swivelling tool rest and the thrust pad (7).
- Fit the nut (8) and tighten down the clamping lever firmly.

Preparations for Sharpening

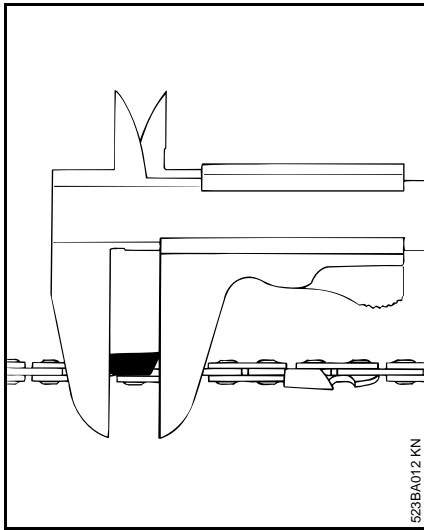

⚠ Do not switch on the motor yet.

- Replace cutters with severely worn or damaged cutting edges. Grind the new cutters back to the shape and size of the other cutters.
- Find the shortest cutter (master cutter).

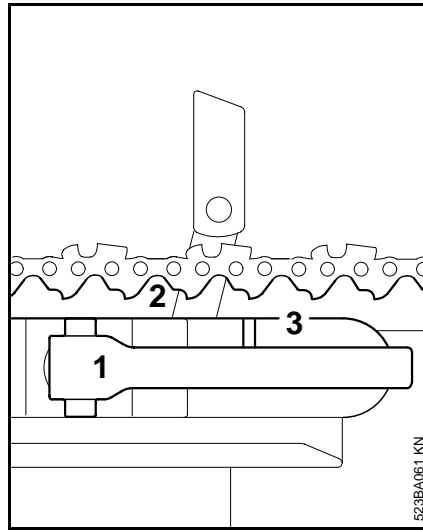

- Release clamping lever (1).
- Place the chain, drive link tangs (2) downward, in the clamping rail (3) – cutting edges must point to the left.

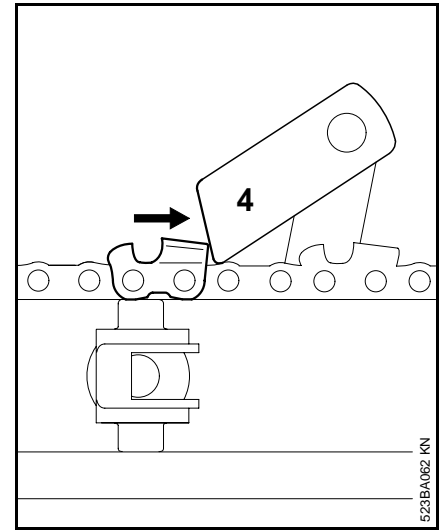

- Pull the master cutter back against the stop (4).

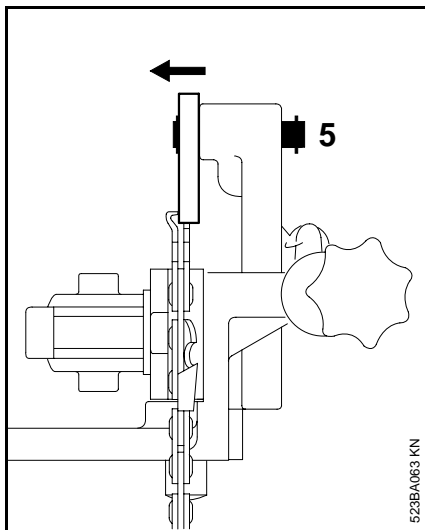

The stop's pivot pin (5) moves backward and forward in the arm.

- To sharpen the left-hand row of cutters: Pull the stop in the direction of arrow.

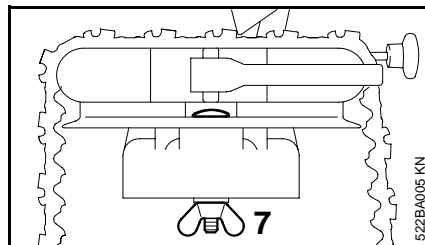
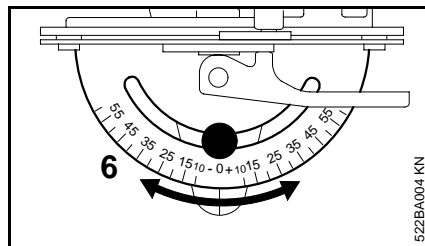

- Set the scale (6) on the swivelling tool rest to the specified sharpening angle (see separate data sheet).
- Tighten down the wingnut (7).

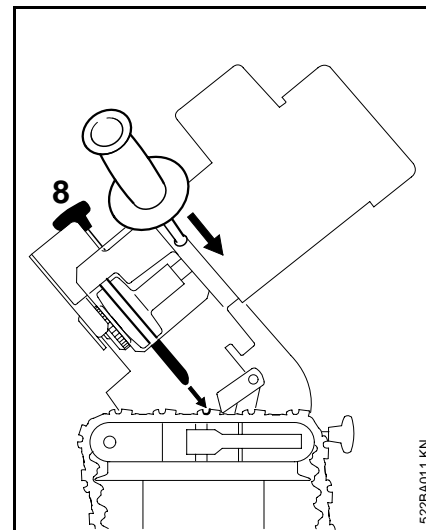

Lateral Adjustment

- Back off the travel limiting screw (8).
- Use the handle to bring the grinding wheel down to the chain.

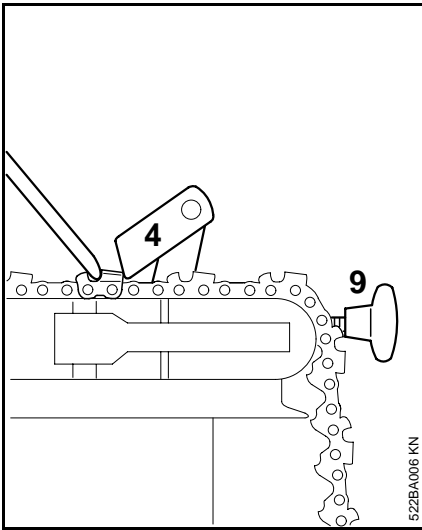

- Move the stop (4) with the adjusting screw (9) so that the master cutter's side plate locates against the grinding wheel.
- Clamp the chain in position.

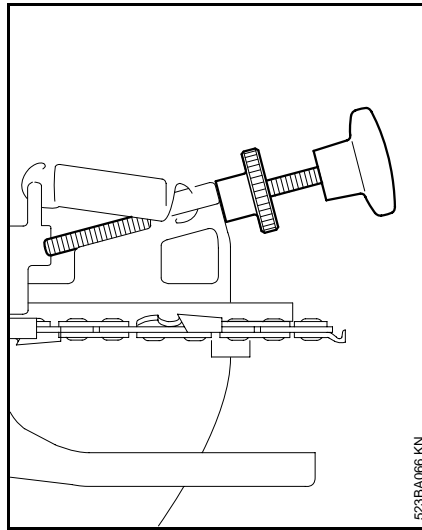

- Lock the adjusting screw in position with the knurled nut.

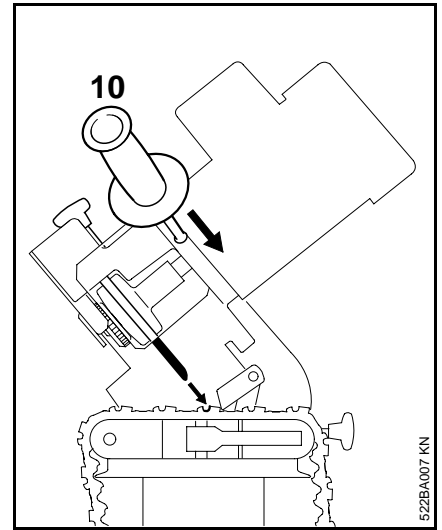

Initial Adjustment of Grinding Depth

- Use the handle (10) to move the motor arm down until the

Sharpening Procedure

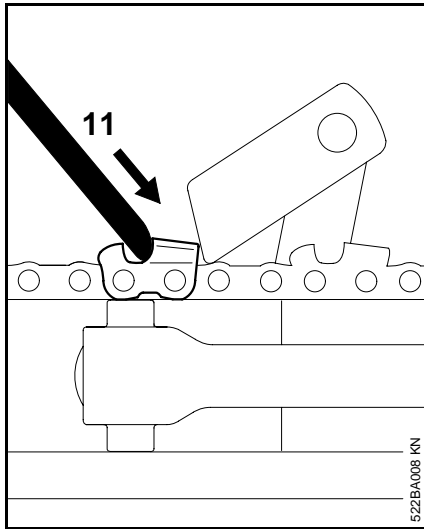

- grinding wheel (11) touches the gullet of the cutter.

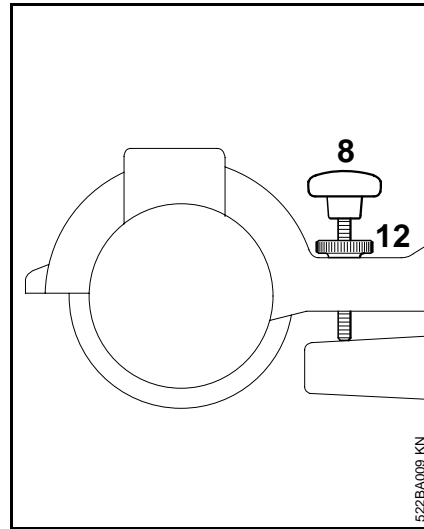

- Screw travel limiting screw (8) down as far as stop lug.
- Tighten down the knurled nut (12) on the travel limiting screw.
- Swing the motor arm back to its neutral position.
- Put on safety glasses.
- Switch on the motor.

- Bring motor arm slowly downward. Check sharpening process. Do not remove too much material.
- If necessary, switch off motor and readjust – see "Lateral Adjustment" in chapter "Preparations for Sharpening".
- Sharpen the side plate by applying the wheel several times – do not sharpen in a single pass.
- When result is satisfactory, check the grinding depth.

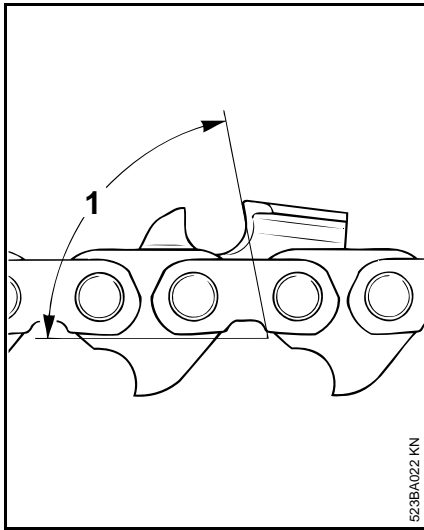

The travel limiting screw must now butt against the stop lug and the side plate angle (1) should be as specified.

Chain type	Angle in degrees
Rapid-Standard	85
Rapid-Micro	85
Rapid-Super	60
Picco-Micro	85
Rapid-Duro	65
RCX, RMX, PMX	80

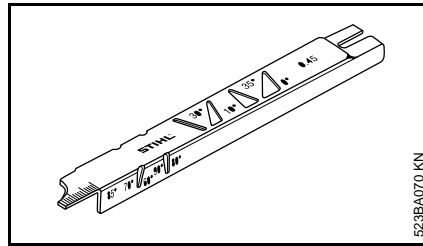

- Use a filing gauge to check sharpening data.

If side plate angle is too obtuse (wide):

- Use travel limiting screw to set motor arm lower.
- ⚠** Avoid touching the drive links or tie straps with the grinding wheel. This could cause the chain to break.

If side plate angle is too acute (narrow):

- Use travel limiting screw to set motor arm higher.
- Lock the adjusting and travel limiting screws with their knurled nuts.

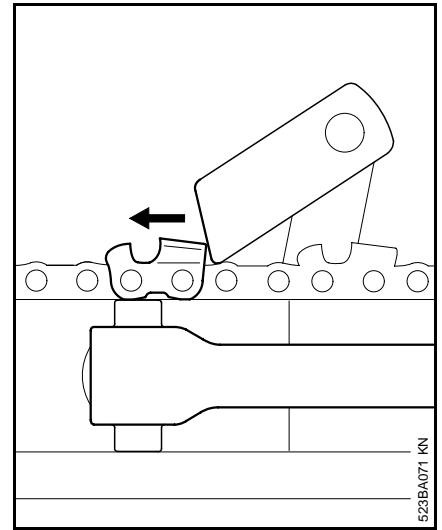

- Release clamping lever. Pull the chain to the left until the stop is behind the next cutter but one.

Lowering Depth Gauges

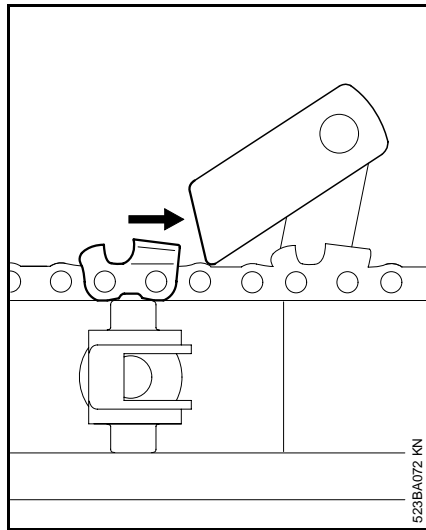

Sharpening Second Row of Cutters

- Rotate swivelling tool rest to the same sharpening angle on the other side of the chain.
- Move the stop's pivot pin so that the stop lines up with the second row of cutters.
- After sharpening first cutter, check its length against that of the other row and adjust the stop if necessary.
- Now sharpen the second row of cutters.

- Pull the chain to the right until the back of the cutter butts against the stop.
- Clamp the chain in position.
- Sharpen the side plate.

Repeat procedure until all side plates on one side have been sharpened.

Checking Depth Gauge Setting

- Select the filing gauge (special accessory) that matches the chain pitch (see separate instruction sheet).

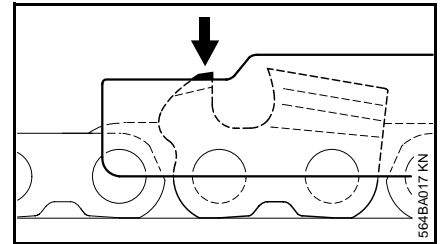

- Place the filing gauge on the saw chain. If the depth gauge projects beyond the filing gauge it has to be lowered.

Setting the Scale

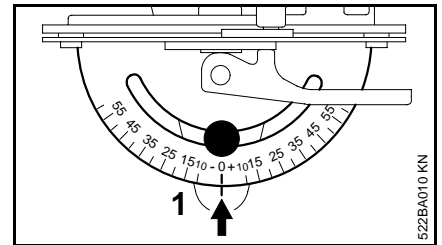

- Set the scale (1) on the swivelling tool rest to "0" and tighten down the M8 wingnut firmly.

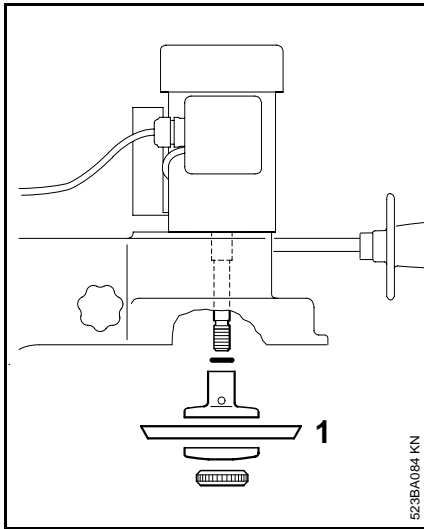

Fitting the Grinding Wheel

- Select grinding wheel (see separate instruction sheet).
- Perform rining test.
- Mount the grinding wheel (1) with its large outside diameter facing the motor – see "Mounting the Grinding Wheel".
- Perform test run – see "Test Run".

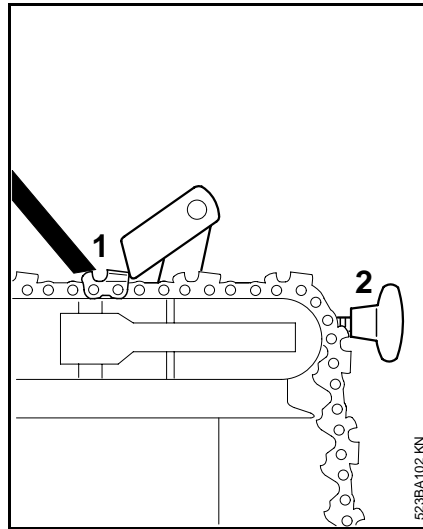

Adjusting the Lateral Stop

- Swing the motor arm down.
- Slide the chain along the guide rail until the profile (1) of the grinding wheel is centered above the depth gauge.
- Clamp the chain in position.
- Turn the adjusting screw (2) until the back of the cutter butts against the stop.

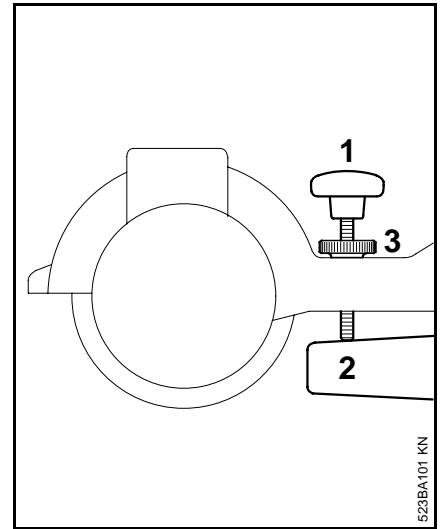

Adjusting Grinding Wheel

- Swing the motor arm down until the grinding wheel touches the depth gauge.
- Screw home the travel limiting screw (1) until it butts against the stop lug (2).
- Put on safety glasses.
- Switch on the motor.
- Carefully bring the motor arm down as far as the stop.

Dressing the Grinding Wheel

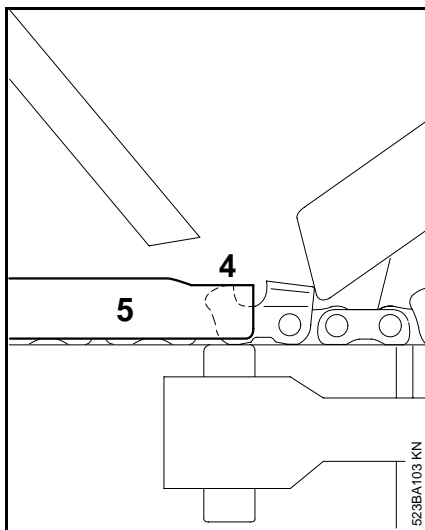

- Switch off the motor.
- Place the filing gauge (5) on the chain.
- If the depth gauge (4) still projects above the filing gauge, make appropriate adjustment with the travel limiting screw (1).
- Remove the filing gauge (5).
- Switch on the motor.
- Carefully bring the motor arm down.
- Switch off the motor.
- Repeat the procedure until the depth gauge is level with the filing gauge.

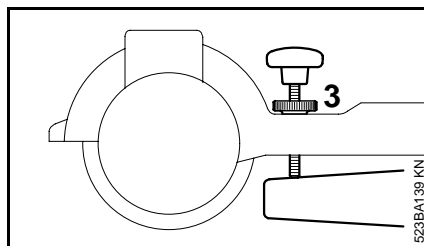

- Tighten down the knurled nut (3) firmly.
 - Use this setting to lower all the other depth gauges.
- ⚠ The kickback tendency of the saw is increased if the depth gauges are too low.
- ⚠ On PM1 and RM2 chains the rear hump of the tie strap (with service mark) is lowered at the same time as the depth gauge. The other parts of the triple-humped tie strap must not be ground because this may increase the kickback tendency of the saw.

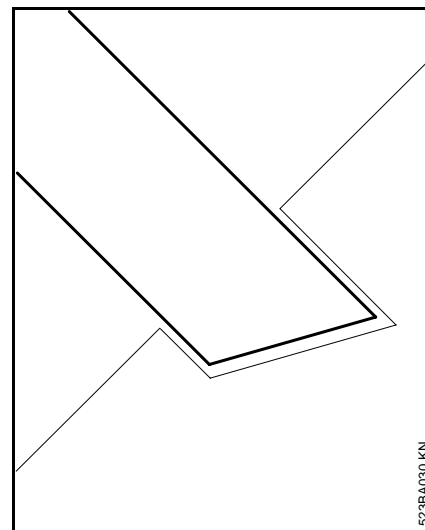

The profile of the grinding wheel is subject to wear.

Switch off the motor.

- Use dressing gauge (special accessory) to check the profile of the grinding wheel.
- Set scale C on swivelling tool rest to "0".
- Use dressing stone (special accessory) to correct the profile of the grinding wheel.

Maintenance Chart

Please note that the following maintenance intervals apply for normal operating conditions. If your daily working time is longer than normal or conditions are difficult, shorten the specified intervals accordingly.		before starting work	after finishing work or daily	weekly	monthly	if problem	if damaged	as required
Complete machine	Visual inspection condition)	X						
	Clean		X					
Machine mounting	Check	X						
	Retighten							X
Switch	Check operation	X						
	Replace ¹⁾					X	X	
Power supply cord	Check	X						
	Replace ¹⁾					X	X	
Grinding wheel	Check (wear)	X						
	Check profile			X				
	Dress			X				X
	Replace						X	X
Cooling air inlets	Clean		X					
Accessible screws and nuts	Retighten							X
Shield	Check	X						
	Replace						X	X
Clamp and guide rail	Check	X						
	Replace							X
Stop and lock	Check	X						
	Replace							X

1) Have work performed by qualified electrician

Minimize Wear and Avoid Damage

Observing the instructions in this manual helps reduce the risk of unnecessary wear and damage to the unit.

The unit must be operated, maintained and stored with the due care and attention described in this owner's manual.

The user is responsible for all damage caused by non-observance of the safety precautions, operating and maintenance instructions in this manual. This includes in particular:

- Alterations or modifications to the product not approved by STIHL.
- Using attachments or sharpening tools not approved by STIHL.
- Using the product for purposes for which it was not designed.
- Consequential damage caused by continuing to use the product with defective components.

Maintenance Work

All the operations described in the "Maintenance Chart" must be performed on a regular basis. If these maintenance operations cannot be performed by the owner, they should be performed by an authorized STIHL servicing dealer.

If these operations are not carried out as specified, the user assumes responsibility for any damage that may occur.

Among other things, this includes:

- Damage to the unit due to neglect or deficient maintenance.
- Corrosion and other consequential damage resulting from improper storage.
- Damage and consequential damage resulting from the use of parts other than original STIHL replacement parts.
- Damage resulting from maintenance or repair work not performed by authorized STIHL servicing dealers.

Parts Subject to Wear and Tear

Some parts of the unit are subject to normal wear and tear even during regular operation in accordance with instructions and, depending on the type and duration of use, have to be replaced in good time.

Among other parts, this includes:

- Grinding wheels
- Carbon brushes
- Transparent shield
- Clamping lever and thrust pad
- Clamping and guide rails
- Stop

Main Parts of Sharpener

Specifications

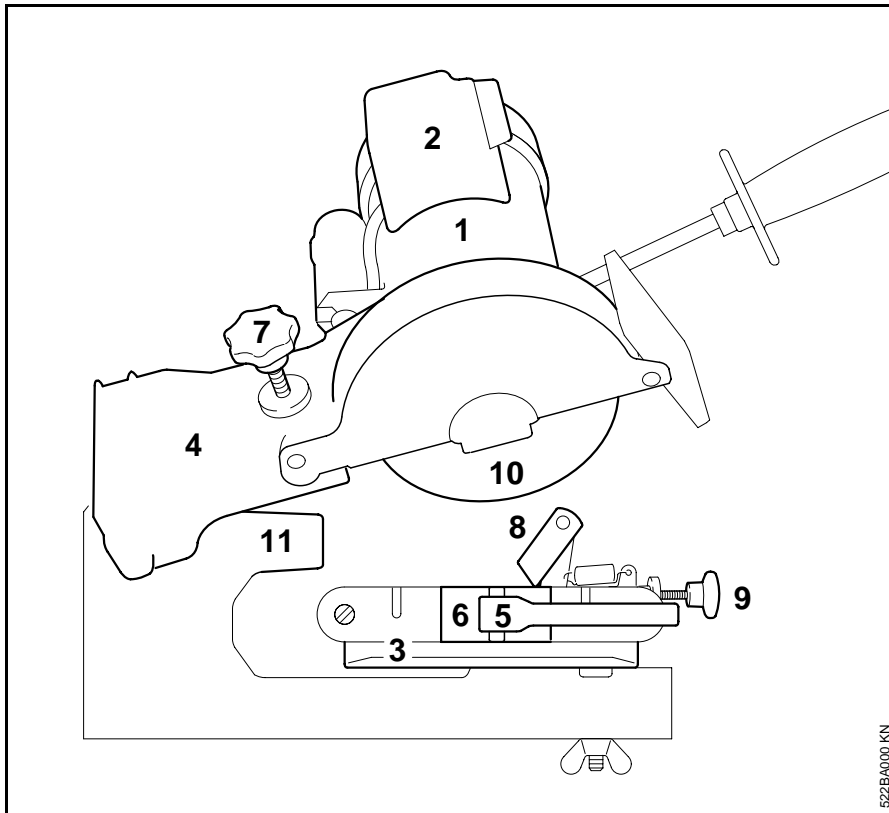

- | | |
|------------------------|-------------------------|
| 1 Motor | 7 Travel limiting screw |
| 2 Switch box | 8 Stop |
| 3 Swivelling tool rest | 9 Adjusting screw |
| 4 Motor arm | 10 Grinding wheel |
| 5 Clamping lever | 11 Stop lug |
| 6 Thrust pad | |

Motor

Type:	Single-phase AC, squirrel-cage motor
Operating voltage:	230 V
Frequency:	50 Hz
Rated current:	1.3 A
Power rating:	0.18 kW
Motor speed:	2,800 RPM
Type of protection:	IP 54 (DIN 40050)
Equivalent sound power level ¹⁾ L _{peq}	75 dB (A)

¹⁾ according to EN ISO 11204,
measured at user's ear while
sharpening a saw chain

Special Accessories

Work light

Dressing gauge

Dressing stone

Maintenance and Repairs

The user of this unit should carry out only the maintenance operations described in this manual. Other repair work may be performed only by an authorized STIHL dealer.

Warranty claims following repairs can be accepted only if the repair has been performed by an authorized STIHL dealer using original STIHL replacement parts.

Original STIHL parts can be identified by the STIHL part number, the **STIHL** logo and the STIHL parts symbol . The symbol may appear alone on small parts.

Certificate of Conformity

Andreas Stihl AG & Co. KG
Badstr. 115
71336 Waiblingen

certify that the new machine described
below

Category: Universal
 sharpener
Make: STIHL
Model: HOS
Serial identification: 5202

conforms to the specifications of
Directives 73/23/EEC, 98/37/EC and
89/336/EEC.

The product has been developed and
manufactured in compliance with the
following standards:
EN 60335-1, EN 55014-1, EN 55014-2,
EN 61000-3-2, EN 61000-3-3 and
EN 60204-1

Technical documents deposited at:
Andreas Stihl AG & Co. KG
Product Licensing

Done at Waiblingen,
September 1, 2003

Andreas Stihl AG & Co. KG



Steinhauser
Director
Group Product Management
Engineering Services

Quality Certification



All STIHL products comply with the highest quality standards.

An independent organization has certified that all products manufactured by STIHL meet the strict requirements of the ISO 9001 standard for quality management systems in terms of product development, materials purchasing, production, assembly, documentation and customer service.

0458 522 0121

englisch / English