

STIHL NG 7

Gebrauchsanleitung

**Instruction Manual
Notice d'emploi
Instrucciones de servicio
Istruzioni d'uso
Instruções de serviço
Handleiding**

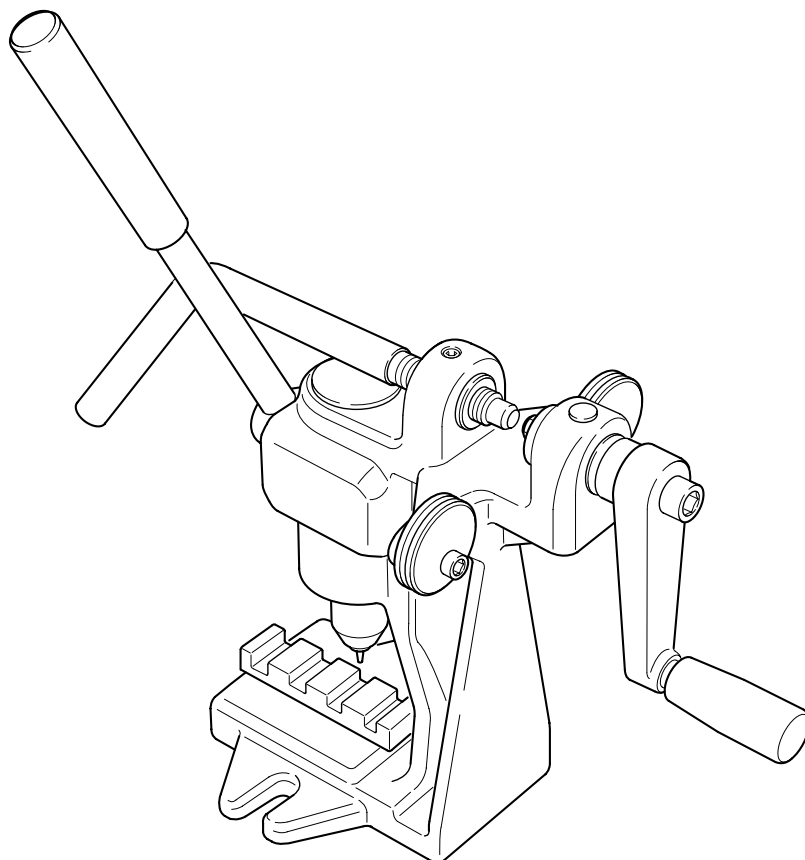

Contents

Guide to Using this Manual	11
Assembling the Rivet Spinner	12
Chain Breaking	13
Rivet Spinning	15
Main Parts	17
Special Accessories	18

Guide to Using this Manual

Pictograms

All the pictograms attached to the machine are shown and explained in this manual.

The operating and handling instructions are supported by illustrations.

Symbols in text

The individual steps or procedures described in the manual may be marked in different ways:

- A bullet marks a step or procedure without direct reference to an illustration.

A description of a step or procedure that refers directly to an illustration may contain item numbers that appear in the illustration.

Example:

Loosen the screw **(1)**

Lever **(2)** ...

STIHL®

Assembling the Rivet Spinner

In addition to the operating instructions, this manual may contain paragraphs that require your special attention. Such paragraphs are marked with the symbols described below:

 Warning where there is a risk of an accident or personal injury or serious damage to property.

 Caution where there is a risk of damaging the machine or its individual components.

 Note or hint which is not essential for using the machine, but may improve the operator's understanding of the situation and result in better use of the machine.

 Note or hint on correct procedure in order to avoid damage to the environment.

* Equipment and features

This instruction manual may refer to several models with different features. Components that are not installed on all models and related applications are marked with an asterisk (*). Such components may be available as special accessories from your STIHL dealer.

Engineering improvements

STIHL's philosophy is to continually improve all of its products. As a result, engineering changes and improvements are made from time to time. If the operating characteristics or the appearance of your machine differ from those described in this manual, please contact your STIHL dealer for assistance.

Therefore some changes, modifications and improvements may not be covered in this manual.

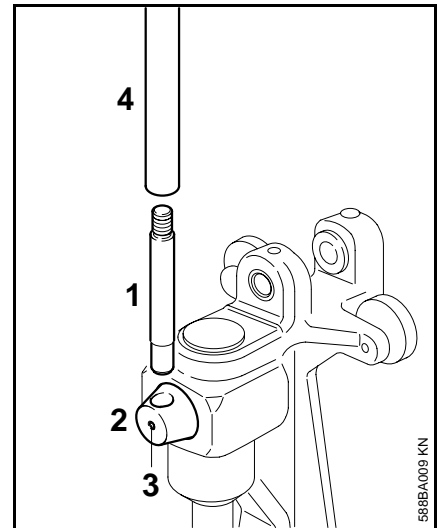

- Use two wood screws and washers to mount the base to the workbench.
- Insert lever (1) in hole in eccentric pin (2) and secure with screw (3).
- Screw extension (4) on to lever (1).

Chain Breaking

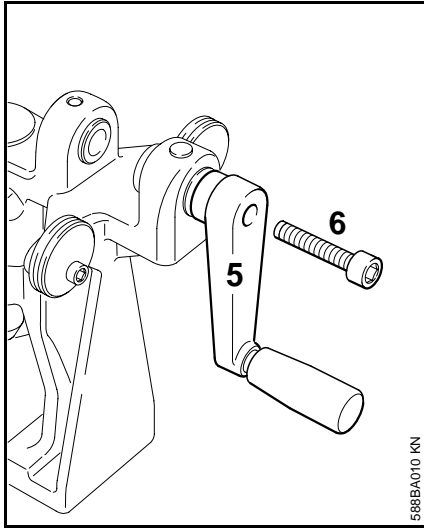

- Fit the crank handle (5) and secure with screw (6).

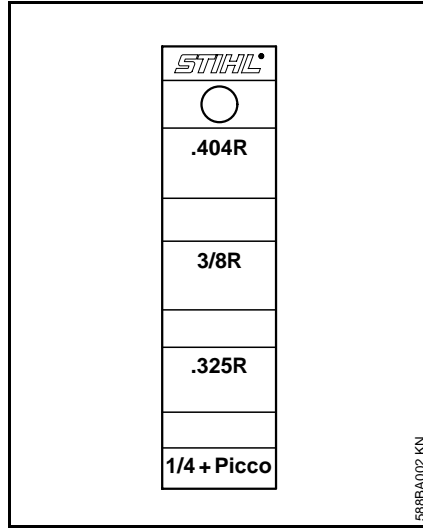

The die has machined recesses for STIHL saw chains which are marked as follows:

Die for STIHL Oilomatic saw chain	Marking
1/4" Rapid, 3/8" Picco	1/4 + Picco
0.325" Rapid	.325R
3/8" Rapid	3/8R
0.404" Rapid	.404R

- Select punch that matches the chain pitch

STIHL Oilomatic saw chain	Punch diameter	
	mm	inch
1/4" Rapid	1.6	0.063
0.325" Rapid	2.2	0.087
3/8" Picco, 3/8" Rapid	2.2	0.087
0.404" Rapid	2.2	0.087

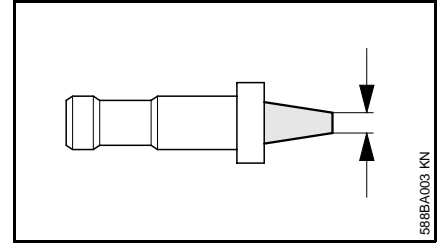

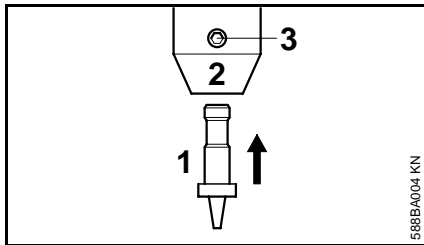

- Fit required punch (1) in the toolholder (2) and secure in position with grub screw (3).

⚠ Improper repairs may result in damage to the chain and increase the risk of injury.

⚠ Wear protective gloves when working with the saw chain to protect your hands from the sharp cutters.

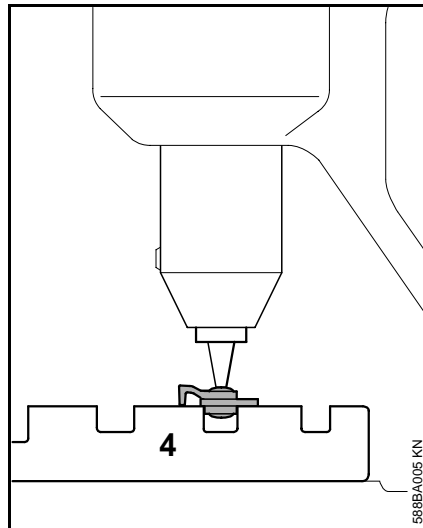

- Place the die (4) on the base plate.
- Position the chain on the die so that the cutter is on top and the tie strap is in the appropriate recess.

💡 Example: Use recess 3/8R for 3/8" Rapid.

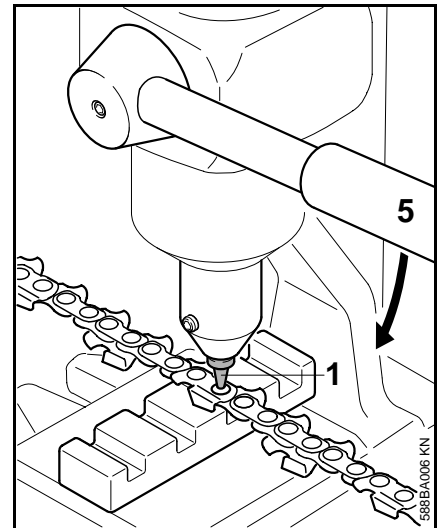

- Bring down the lever (5) until the punch (1) touches the rivet.
- ⚙ The rivet to be removed must be centered under the punch.
- Push the lever down until the rivet head is pressed out.

Rivet Spinning

⚠ Non-approved combinations of cutters and/or chain links can increase the kickback tendency of the chain and expose the user to injury.

⚠ Wear protective gloves when working with the saw chain to protect your hands from the sharp cutters.

- Select spinning head and thrust screw to suit the chain pitch

STIHL Oilomatic chain	Spinning head	Thrust screw
1/4" Rapid, 3/8" Picco, 0.325" Rapid	C	C
3/8" Rapid , 0.404" Rapid	A	A, B
1/2", 15 mm Rapid Micro	B	A, B

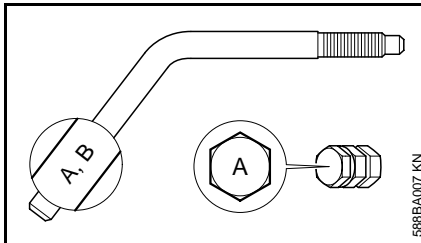

- Do not alter the chain link assembly pattern.
- Use only identical replacement chain links.

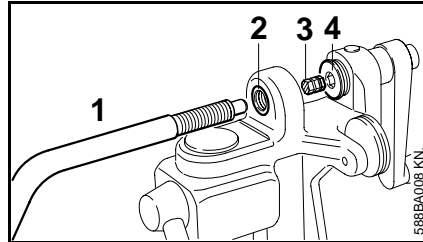

- Screw the thrust screw (1) into the threaded bushing (2) clockwise.
- Place spinning head (3) in the holder (4).

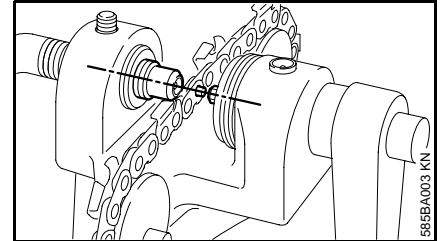
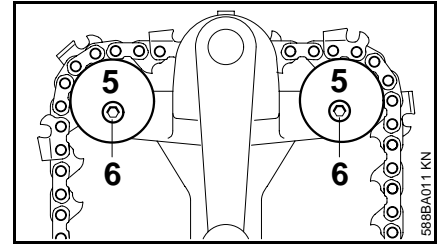

- Fit the matching chain links on a preset tie strap and place the saw chain over the two guide pulleys (5) - the drive link tangs engage the groove.
- Loosen screws (6) and rotate the eccentric guide pulleys until the rivets in the chain links are horizontal and in alignment with spinning head. The preset head of the tie strap must locate in the recessed end of the thrust screw.
- Tighten down the screws.

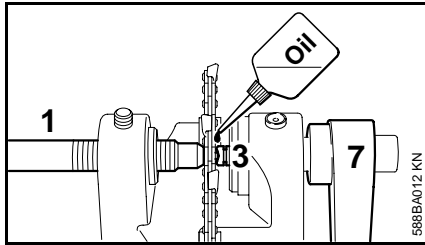

- Advance the thrust screw **(1)** until the shank of the rivet butts against the spinning head **(3)**.
- Apply a few drops of oil to the rivet and the face of the spinning head.
- Turn the thrust screw **(1)** clockwise with one hand until moderate pressure is applied to the rivet.
- Turn the crank handle **(7)** steadily with the other hand – the spinning head forms the new rivet head. Continue turning the thrust screw to maintain a constant pressure on the rivet.
- Spin the rivet until the chain links are firmly connected but still flexible.

The new chain link must be matched to the size and shape of the other links:

- Grind back cutter and depth gauge to size of master cutter (the master cutter is the shortest cutter in the chain, see user manual of grinder).
- File back surface of the new tie strap to size and shape of other links.

Main Parts

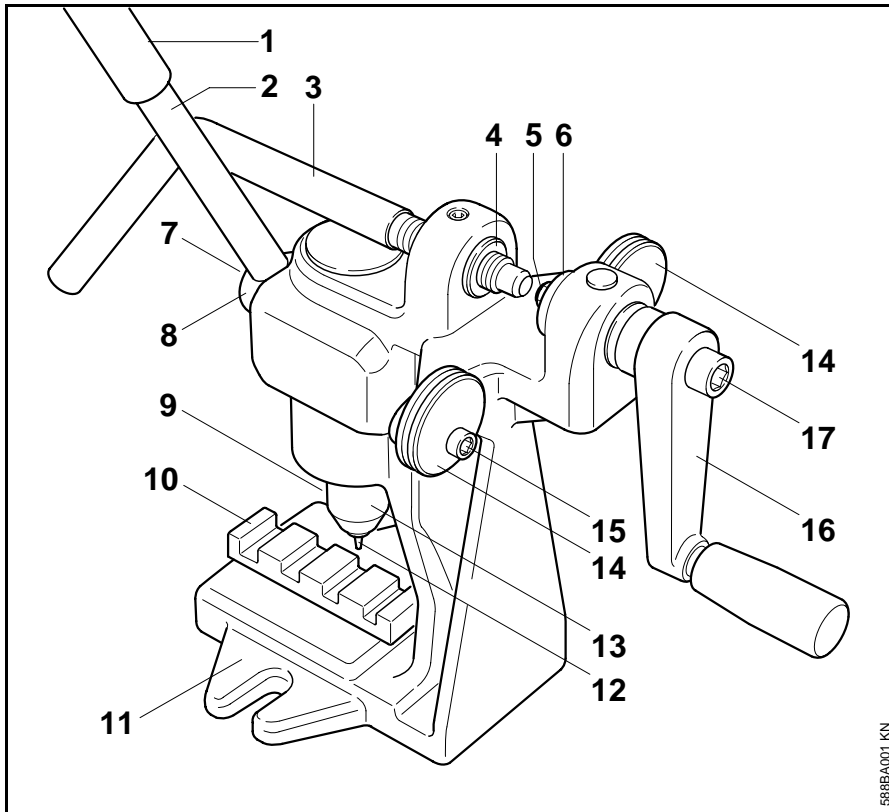

- 1 Extension
- 2 Lever
- 3 Thrust screw
- 4 Threaded bush
- 5 Spinning head
- 6 Thrust bearing
- 7 Grub screw
- 8 Eccentric pin
- 9 Grub screw
- 10 Die
- 11 Base
- 12 Punch
- 13 Toolholder
- 14 Guide pulley
- 15 Screw
- 16 Crank handle
- 17 Screw

English

Special Accessories

For breaking and riveting 15 mm chain:

Die (15 mm)

Punch (15 mm)

Guide pulley (15 mm)

Spinning head (1/2 " and 15 mm)

0458 588 7721

MF