

# **STIHL KW 85**

Instruction Manual

Owner's Manual

Assembling

Safety Precautions

Operating Instructions

Maintenance



**Warning:**  
Always follow safety precautions in  
Owner's Manual - improper use  
can cause serious injury!

## Contents

Allow only persons who understand this Manual to operate your PowerSweep. To receive maximum performance and satisfaction from your STIHL PowerSweep, it is important that you read and understand the maintenance and safety precautions, starting on page 3, before using your PowerSweep.

Contact your STIHL dealer or the STIHL distributor for your area if you do not understand any of the instructions in this Manual.

### **Warning!**

Because a PowerSweep is a power tool, some special safety precautions must be observed to reduce the risk of personal injury.

Careless or improper use may cause serious or even fatal injury.

Always wear proper eye protection.

STIHL's philosophy is to continually improve all of its products. As a result, engineering changes and improvements are made from time to time. If the operating characteristics or the appearance of your PowerSweep differs from those described in this Manual, please contact your STIHL dealer for information and assistance.

Printed on chlorine-free paper

Printing inks contain vegetable oils, paper is recyclable

© 2001 Andreas Stihl AG & Co., Waiblingen

0458 223 3021. M0,25. C1. PM. Printed in USA

KW 85

Guide to Using this Manual .....	2
Safety Precautions and Working Techniques .....	3
Fitting Carrying Eye* (Clamp) .....	10
Mounting the Loop Handle .....	10
Installing the Gearbox .....	11
Mounting Sweeper Drums .....	12
Fuel .....	13
Fueling .....	14
Attaching Machine to Harness* .....	14
Starting .....	15
Operating Instructions .....	18
Using the PowerSweep .....	18
Disconnecting Machine from Harness .....	19
Cleaning the Air Filter .....	20
Motor Management .....	21
Adjusting the Carburetor .....	21
Adjusting the Carburetor .....	22
Checking the Spark Plug .....	24
Removing the Gearbox .....	25
Replacing the Rubber Sleeve .....	25
Replacing Sweeper Drum .....	26
Replacing the Starter Rope and Rewind Spring .....	26
Spark Arresting Screen in Muffler ..	29
Engine Running Behavior .....	30
Storing the Machine .....	30
Maintenance Chart .....	31
Parts and Controls .....	32
Specifications .....	34
Special Accessories .....	35
Maintenance and Repairs .....	35
STIHL Incorporated Federal and California Emission Control Warranty Statement .....	36
Quality Certification .....	38

**STIHL®**

## Guide to Using this Manual

### Pictograms

All the pictograms attached to the machine are shown and explained in the this manual.

The operating and handling instructions are supported by illustrations.

### Symbols in text

The individual steps or procedures described in the manual may be marked in different ways:

- Step or procedure without direct reference to an illustration.

Description of step or procedure that refers directly to the illustration and contains item numbers that appear in the illustration.

Example:

Loosen the screw **(1)**

Lever **(2)** ...

In addition to the operating instructions, this manual may contain paragraphs that require your special attention. Such paragraphs are marked with the symbols described below:

 Warning where there is a risk of an accident or personal injury or serious damage to property.

 Warning where there is a risk of damaging the power tool or individual components.

 Note or hint which is not essential for using the power tool, but may improve the operator's understanding of the situation and result in better use of the power tool.

 Note or hint on correct procedure in order to avoid damage to the environment.

### \* Equipment and features

This instruction manual refers to several models with different features. Components that are not installed in all models and related applications are marked thus \*. Such components are available as special accessories from your STIHL dealer.

### Engineering improvements

STIHL's philosophy is to continually improve all of its products. As a result, engineering changes and improvements are made from time to time. If the operating characteristics or the appearance of your machine differ from those described in this manual, please contact your STIHL dealer for assistance.

## Safety Precautions and Working Techniques



### Warning!

Because a PowerSweep is a power tool, special safety precautions must be observed to reduce the risk of personal injury.



It is important that you read, fully understand and observe the following safety precautions and warnings. Read the owner's manual and the safety instructions periodically. Careless or improper use of any PowerSweep may cause serious or fatal injury. Have your STIHL dealer show you how to operate your PowerSweep. Observe all applicable local safety regulations, standards and ordinances.



### Warning!

Minors should never be allowed to use a PowerSweep. Bystanders, especially children, and animals should not be allowed in the area where a PowerSweep is in use.

Never let the PowerSweep run unattended.



### Warning!

Do not lend or rent your PowerSweep without the owner's manual. Be sure that anyone using your PowerSweep understands the information contained in this manual.

Most of these safety precautions and warnings apply to the use of all STIHL PowerSweeps. Different models may have different parts and controls. See the appropriate section of your owner's manual for a description of the controls and function of the parts of your model PowerSweep.

Safe use of a PowerSweep involves

1. the operator
2. the PowerSweep
3. the use of the PowerSweep .

## THE OPERATOR!

### Physical Condition

You must be in good physical condition and mental health and not under the influence of any substance (drugs, alcohol, etc.) which might impair vision, dexterity or judgment. Do not operate a PowerSweep when you are fatigued.

Be alert - if you get tired while operating your PowerSweep, take a break. Tiredness may result in loss of control. Working with any PowerSweep can be strenuous. If you have any condition that might be aggravated by strenuous work, check with your doctor before operating a PowerSweep.



### Warning!

Prolonged use of a PowerSweep (or other machines) exposing the operator to vibrations may produce whitefinger disease (Raynaud's phenomenon) or carpal tunnel syndrome. These conditions reduce the hand's ability to feel and regulate temperature, produce numbness and burning sensations and may cause nerve and circulation damage and tissue necrosis.

All factors which contribute to whitefinger disease are not known, but cold weather, smoking and diseases or physical conditions that affect blood vessels and blood transport, as well as high vibration levels and long periods of exposure to vibration are mentioned as factors in the development of whitefinger disease.

In order to reduce the risk of whitefinger disease and carpal tunnel syndrome, please note the following:

- Most STIHL power tools are equipped with an anti-vibration ("AV") system designed to reduce the transmission of vibrations created by the engine to the operator's hands. An AV system is recommended for those persons using power tools on a regular or sustained basis.
- Wear gloves and keep your hands warm.
- Keep the AV system well maintained. A PowerSweep with loose components or with damaged or worn AV buffers will tend to have higher vibration levels.
- Maintain a firm grip at all times, but do not squeeze the handles with constant, excessive pressure, take frequent breaks.

All the above mentioned precautions do not guarantee that you will not sustain whitefinger disease or carpal tunnel syndrome. Therefore, continual and regular users should monitor closely the condition of their hands and fingers. If any of the above symptoms appear, seek medical advice immediately.

 **Warning!**

The ignition system of the STIHL unit produces an electromagnetic field of a very low intensity. This field may interfere with some pacemakers. To reduce the risk of serious or fatal injury,

persons with pacemaker should consult their physician and the pacemaker manufacturer before operating this tool.

**Proper Clothing**

 **Warning!**

To reduce the risk of injury, the operator should wear proper protective apparel.



Never operate a PowerSweep unless wearing goggles or properly fitted safety glasses with adequate top and side protection complying with your National Standard.



PowerSweep noise may damage your hearing. Wear sound barriers (ear plugs or ear muffs) to protect your hearing. Continual and regular users should have their hearing checked regularly.



Protect your hands with gloves when handling the PowerSweep. Heavy-duty, nonslip gloves improve your grip and protect your hands.



Clothing must be sturdy and snug-fitting, but allow complete freedom of movement. Avoid loose-fitting jackets, scarfs, neckties, jewelry, flared or cuffed pants, unconfined longhair or moving parts of the unit. Wear long pants made of heavy material to protect your legs. Do not wear shorts, sandals or go bare foot. Secure hair so it is above shoulder level.



Good footing is important in PowerSweep work. Wear sturdy boots with nonslip soles.



Wear an approved safety hard hat to reduce the risk of injury to your head when there is a danger of head injuries.

## THE POWER SWEEP

For illustrations and definitions of the PowerSweep parts see the chapter on "Parts and Controls"

### **Warning!**

Never modify a PowerSweep in any way. Only attachments supplied by STIHL or expressly approved by STIHL for use with the specific STIHL PowerSweep models are authorized. Although certain unauthorized attachments may be useable for the STIHL Power Sweep, their use may, in fact, be extremely dangerous.

## THE USE OF THE POWER SWEEP

### Transporting the PowerSweep

#### **Warning!**

Always turn off the engine and make sure the attachment has stopped before putting a PowerSweep down. When transporting your PowerSweep in a vehicle, properly secure it to prevent turnover, fuel spillage and damage to the PowerSweep.

### Preparation for the use of the PowerSweep

Adjust carrying harness and hand grip to suit your size before starting work. The machine should be properly balanced as specified in your owner's manual for proper control and less fatigue in operation.

Always check your PowerSweep for proper condition and operation before starting, particularly the throttle trigger, throttle trigger interlock (if applicable), stop switch, sweeper drums, rubber sleeve and harness.

The throttle trigger must move freely and always spring back to the idle position. The sweeper must be properly tightened and in safe operating condition. Both sweeper belts must be mounted. The rubber sleeve on the end of the drive tube must be in good condition. Do not operate your PowerSweep with damaged sweeper drums or rubber sleeve. Inspect for loose parts (nuts, screws, etc) and for worn or damaged parts. Replace worn or damaged parts.

### Fueling

Your STIHL PowerSweep uses an oil-gasoline mixture for fuel (see the chapter on "Fuel" of your owner's manual).

### **Warning!**



Gasoline is an extremely flammable fuel. If spilled and ignited by a spark or other ignition source, it can cause fire and serious burn injury or property

damage. Use extreme caution when handling gasoline or fuel mix.

Do not smoke or bring any fire or flame near the fuel.

### Fueling Instructions

Fuel your PowerSweep in well-ventilated areas, outdoors only.

#### **Warning!**

Gasoline vapor pressure may build up inside the gas tank of a two cycle engine depending on the fuel used, the weather conditions, and the venting system of the tank. In order to reduce the risk of burns and other personal injury from escaping gas vapor and fumes, remove the fuel filler cap on your PowerSweep carefully so as to allow any pressure build-up in the tank to release slowly.



Never remove fuel filler cap while engine is running. Select bare ground for fueling and move at least 10 feet (3 m) from the fueling spot before starting the engine. Wipe off any spilled fuel before starting your PowerSweep and check for leakage.

**⚠ Warning!**

Check for fuel leakage while refueling and during operation. If fuel or oil leakage is found, do not start or run the engine until leak is fixed and spilled fuel has been wiped away. If this happens, change your clothing immediately.

**⚠ Warning!**



Unit vibrations can cause an improperly tightened fuel cap to loosen or come off and spill quantities of fuel. In order to reduce risk of fuel spillage and

fire, tighten fuel cap by hand with as much force as possible.

## OPERATING INSTRUCTIONS

### Starting

**⚠ Warning!**

Your PowerSweep is a one-person machine. If you start the engine in the "start position" the sweeper belts will rotate when the engine starts - this may set the PowerSweep in motion back towards the operator.

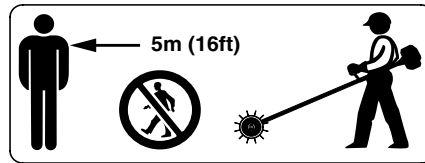

To reduce the risk of injury from thrown objects or contact with the sweeper belts, do not allow any other person within a radius of 5 m (15 f) of your own position.

Stop the engine immediately if you are approached. Start and operate your PowerSweep without assistance. For specific starting instructions, see the appropriate section of your manual. Place the PowerSweep on firm ground or other solid surface in an open area. Maintain a good balance and secure footing.

**⚠ Warning!**

When you pull the starter grip, don't wrap the starter rope around your hand. Do not allow the grip to snap back, but guide the starter rope to rewind it properly. Failure to follow this procedure may result in injury to hand or fingers and may damage the starter mechanism.

With the engine running but at idle, attach the PowerSweep to the spring hook of your harness (see appropriate chapter of this manual).

### Working Conditions

Operate and start your PowerSweep only outdoors in a well ventilated area.

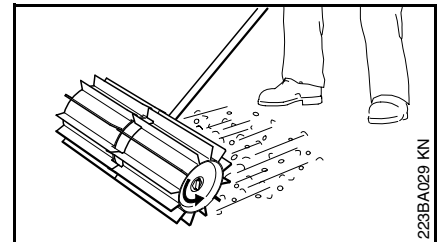
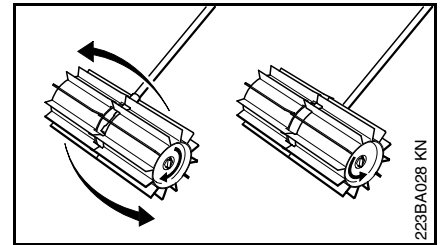

**⚠ Warning!**

Reversing the PowerSweep will cause debris to be thrown back towards the operator. When reversing the PowerSweep, use lower throttle settings and be aware that thrown debris may also affect your footing.

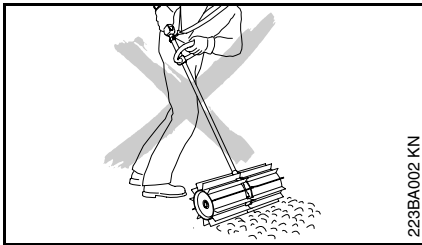
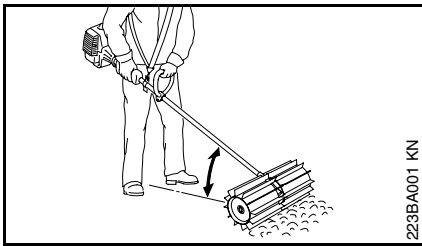

**⚠ Warning!**

To reduce the risk of injury from loss of control, maintain a low angle to the work surface. A high angle of operation tends to propel the PowerSweep toward you.

**⚠ Warning!**



Your PowerSweep produces toxic exhaust fumes as soon as the engine is running. These gases (e.g. carbon monoxide) may be colorless and odorless. To reduce the risk of serious or fatal injury from inhaling toxic fumes, never run the PowerSweep indoors or in poorly ventilated locations.

**⚠ Warning!**

Use of this product can generate dust and fumes containing chemicals known to cause respiratory disease, cancer, birth defects, or other reproductive harm. If you are unfamiliar with the risks associated with the particular dust or fume at issue, consult your employer, governmental agencies such as OSHA and NIOSH and other sources on hazardous materials. California and some other authorities, for instance, have published lists of substances known to cause cancer, reproductive toxicity, etc.

Control dust and fumes at the source where possible. In this regard use good work practices and follow the recommendations of OSHA/NIOSH and occupational and trade associations. When the inhalation of toxic dust and fumes cannot be eliminated, the operator and any bystanders should always wear a respirator approved by NIOSH/MSHA for the type of dust and / or fumes encountered.

**⚠ Warning!**

The muffler and other parts of the engine (e.g. fins of the cylinder, spark plug) become hot during operation and remain hot for a while after stopping the engine. To reduce risk of burns do not touch the muffler and other parts while they are hot.

Operate the PowerSweep under good visibility and daylight conditions only. Work carefully.

The PowerSweep is designed only for sweeping sand, stones, gravel, leaves and snow on grass, concrete or asphalt and removing puddles of water from flat surfaces. To reduce the risk of injury, do not use your PowerSweep for any other purpose.



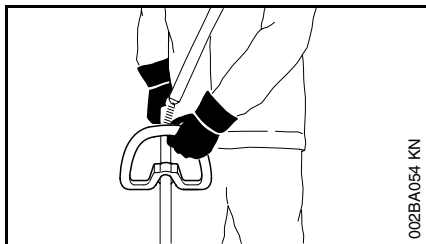

Always hold the PowerSweep firmly with both hands. Wrap your fingers tightly around the handles, keeping the handles cradled between your thumb and fore-finger. Keep your hands in this position, to have your PowerSweep under control at all times. Make sure your PowerSweep handles and grip are in good condition and free of moisture, pitch, oil or grease.

**⚠ Warning!**

Never attempt to operate any PowerSweep with one hand. Loss of control of the PowerSweep may result in personal injury.

Special care must be taken in slippery conditions (wet ground, snow).



Examine work area and check for solid objects (such as stones, pieces of metal, etc.) which could be thrown and cause injury or damage the sweeper flaps or other property (e.g. parked vehicles, windows, etc.).

**⚠ Warning!**

This PowerSweep is to be used at ground level with the sweeper belts parallel to the ground. Use of a PowerSweep above ground level may increase the risk of injury, since the brooming attachment is more fully exposed and the PowerSweep may be more difficult to control.

Do not operate the PowerSweep using the starting throttle lock as you do not have control of the engine speed. See section of your owner's manual on the proper use of the slide control.

If the sweeper belts become clogged or stuck, always turn off the engine and make sure the sweeper belts have stopped, before cleaning.

### Important adjustments

**⚠ Warning!**

To reduce the risk of personal injury from loss of control or contact with the running sweeper drums, do not use your PowerSweep with incorrect idle adjustment. At correct idle speed, the sweeper drums should not move. For directions on how to adjust idle speed, see the appropriate section of your owner's manual.

If you cannot set the correct idle speed, have your STIHL dealer check your PowerSweep and make proper adjustments and repairs.

### MAINTENANCE, REPAIR AND STORING

**Maintenance, replacement, or repair of the emission control devices and systems may be performed by any nonroad engine repair establishment or individual. However if you claim warranty for a component which has not been serviced or maintained properly or if nonapproved replacement parts were used, STIHL may deny warranty.**

Use only identical STIHL replacement parts for maintenance and repair. Use of non-STIHL parts may cause serious or fatal injury.

Follow the maintenance and repair instructions in the appropriate section of your owner's manual. Please refer to the maintenance chart at the last pages of this manual.

 **Warning!**

Always stop the engine and make sure that the sweeper belts have stopped before doing any maintenance or repair work or cleaning the PowerSweep. Do not attempt any maintenance or repair work not described in your owner's manual. Have such work performed at your STIHL dealer shop only.

 **Warning!**

Check condition of sweeper belts at regular intervals. Loose particles or pieces of the belts could be thrown and injure the operator or bystanders. To reduce risk of injury from broken parts replace damaged sweeper belts immediately and always in pairs. Do not reuse or attempt to repair damaged or worn sweeper belts.

 **Warning!**

To reduce the risk of fire and burn injuries, check fuel filler cap for leaks at regular intervals. Use the specified spark plug and make sure it and the ignition lead are always in good condition.

 **Warning!**

Never test the ignition system with ignition wire boot removed from spark plug or with unseated spark plug, since uncontained sparking may cause a fire.

 **Warning!**

To reduce the risk of fire and burn injury, use only spark plugs authorized by STIHL. Always press spark plug boot snugly onto spark plug boot of the proper size. (Note: If boot has detachable SAE adapter nut, it must be attached.) A loose connection between spark plug boot and ignition wire connector in the boot may create arcing that could ignite combustible fumes and cause a fire. Keep spark plug clean, and make sure ignition lead is in good condition.

 **Warning!**

Do not operate your PowerSweep if the muffler is damaged, missing or modified. An improperly maintained muffler will increase the risk of fire and hearing loss. Never touch a hot muffler or burn will result. If your muffler was equipped with a spark-arresting screen to reduce the risk of fire (e.g. in the USA, Canada and Australia), never operate your PowerSweep if the screen is missing or damaged. Do not modify or remove any part of the muffler or spark arresting screen. Remember that the risk of forest fires is greater in hot or dry weather.

Tighten all nuts, bolts and screws, except the carburetor adjustment screws, after each use.

Additionally, the daily maintenance schedule for your PowerSweep set forth in your STIHL Owner's Manual should be strictly followed.

For any maintenance please refer to the maintenance chart **and to the warranty statement** near the end of this manual.

Store PowerSweep in a dry, high or locked location out of reach of children.

Before storing for longer than a few days, always empty the fuel tank.

## Fitting Carrying Eye\* (Clamp)

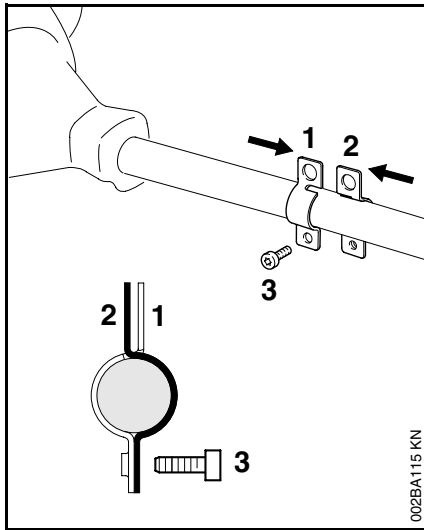

- For position of carrying eye (clamp)\* see "Parts and Controls"
- Place the clamp (1) **with** tapped hole against the left-hand side of the drive tube.
- Place the other half of the clamp (2) against the right-hand side of the drive tube.
- Slide the two clamps together so that their slots engage.
- Insert M 6 x 14 screw (3).
- Line up the carrying eye.
- Tighten down the screw.

## Mounting the Loop Handle

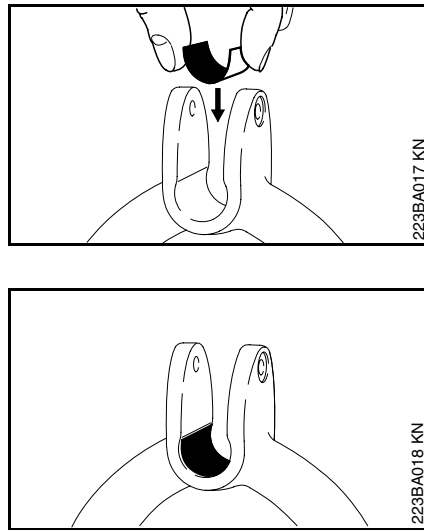

- Place liner in loop handle as shown.

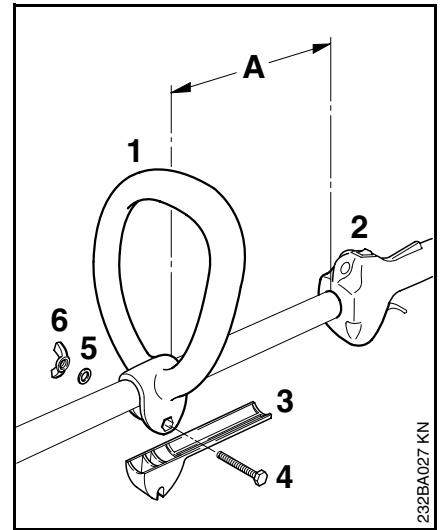

- Fit the loop handle (1) on the drive tube approx. 8 in (20cm) (A) forward of the control handle (2).
- Slide spacer (3) into loop handle as far as stop.
- Insert screw (4) in loop handle and through spacer until the hexagon head engages the socket in the loop handle.
- Fit washer (5) and wingnut (6) and tighten down firmly.

\* see "Guide to Using this Manual"

## Installing the Gearbox

### Adjusting loop handle to most comfortable position:

- Loosen the wingnut (6).
- Turn or move loop handle (1) along drive tube as required.
- Tighten down wingnut (6) firmly.

Two different versions are supplied at the present time:

### Sleeve on drive tube

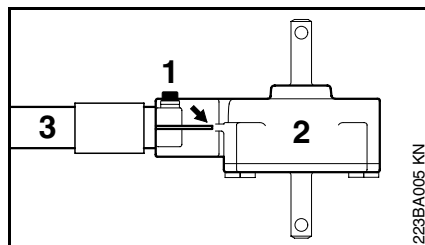

- Release the clamp screw (1).
- Degrease the drive tube in the area of the clamp.
- Slide the gearbox (2) onto the drive tube (3) - turn the gearbox back and forth at the same time until the end of the tube is no longer visible in the slot (arrow).
- Push gearbox on as far as stop.

### Sleeve on gearbox

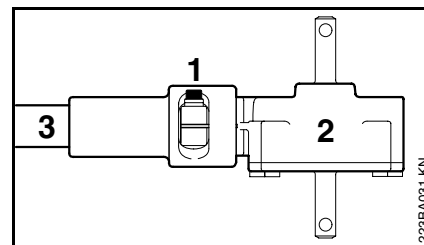

- Release the clamp screw (1).
- Degrease the drive tube in the area of the clamp.
- Slide the gearbox with sleeve (2) onto the drive tube (3) - turn the gearbox back and forth at the same time.
- Push gearbox on as far as stop.

## Mounting Sweeper Drums

### Aligning the gearbox

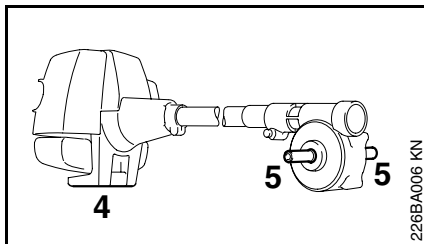

- Line up the gearbox on the drive tube so that machine support (4) faces down and the drive shafts (5) are horizontal.
- Tighten down the clamp screw.

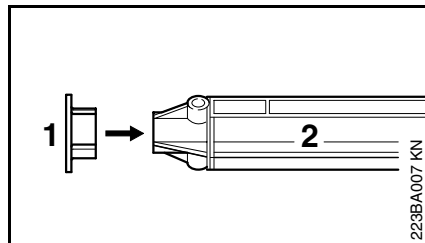

- Fit grass shield (1) on end of axle (2) and press home as far as stop.

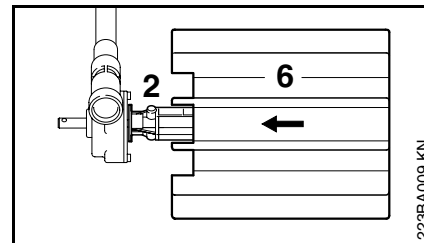

- Push sweeper drum assembly (6) onto the axle (2) - note the installed position (see illustration).

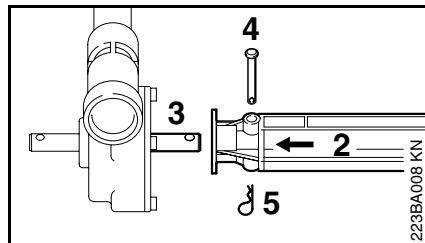

- Push axle (2) onto the output shaft (3).
- Insert pin (4) through axle and output shaft. Secure pin with cotter pin (5).

## Fuel

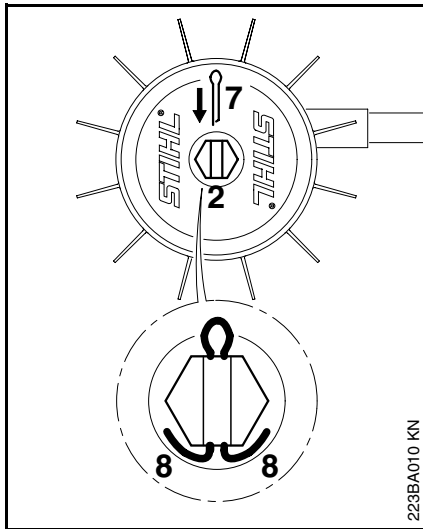

- Fit new cotter pin (7) in end of axle (2) and bend over the ends (8) of the cotter pin as shown.
- Repeat the procedure on the other side.
- Always mount both sweeper drum assemblies.

This engine is certified to operate on unleaded gasoline and with the mix ratio 50:1.

Your two-stroke engine requires a mixture of brand-name gasoline and quality two-stroke engine oil with the **classification TC**.

Use regular branded unleaded gasoline with a minimum octane rating of 89 RON. If the octane rating of the regular grade gasoline in your area is lower use premium unleaded fuel.

Fuel with a lower octane rating may result in preignition (causing "pinging") which is accompanied by an increase in engine temperature. This, in turn, increases the risk of the piston seizure and damage to the engine.

The chemical composition of the fuel is also important. Some fuel additives not only detrimentally affect elastomers (carburetor diaphragms, oil seals, fuel lines etc.), but magnesium castings as well. This could cause running problems or even damage the engine. For this reason it is essential that you use only name branded fuels!

Use only STIHL two-stroke engine oil or equivalent branded two-stroke air-cooled engine oils with the classification TC for mixing.

We recommend STIHL 50:1 two-stroke engine oil since it is specially formulated for use in STIHL engines.

Do not use BIA or TCW (two-stroke water cooled) mix oils!

Take care when handling gasoline. Avoid direct contact with the skin and avoid inhaling fuel vapour.

The canister should be kept tightly closed in order to avoid any moisture getting into the mixture.

The fuel tank and the canister in which fuel mix is stored should be cleaned from time to time.

### Fuel mix ages

Only mix sufficient fuel for a few days work, not to exceed 3 months of storage. Store in approved safety fuel-canisters only. When mixing, pour oil into the canister first, and then add gasoline.

Gasoline	Oil (STIHL 50:1 or equivalent branded TC oils)
----------	--

US gal.	US fl.oz
1	2.6
2 1/2	6.4
5	12.8

Dispose empty mixing-oil canisters only at authorized disposal locations.

## Fueling

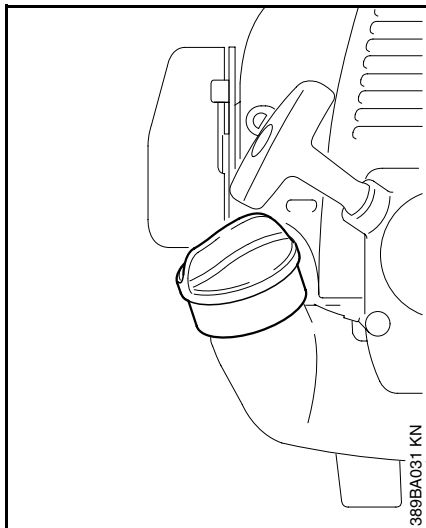

Before fueling, clean the filler cap and the area around it to ensure that no dirt falls into the tank.

Always thoroughly shake the mixture in the canister before fueling your machine.

**⚠** In order to reduce the risk of burns or other personal injury from escaping gas vapor and fumes, remove the fuel filler cap carefully so as to allow any pressure build-up in the tank to release slowly.

**⚠** After fueling, tighten fuel cap **as securely as possible** by hand.

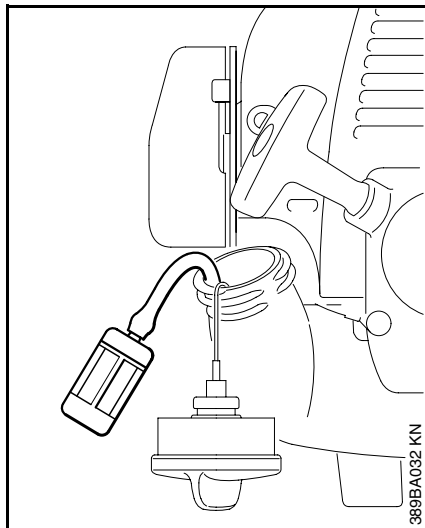

**Change the fuel pick up body every year.**

- Before storing your machine for a long period, drain and clean the fuel tank and run engine until carburetor is dry.

## Attaching Machine to Harness\*

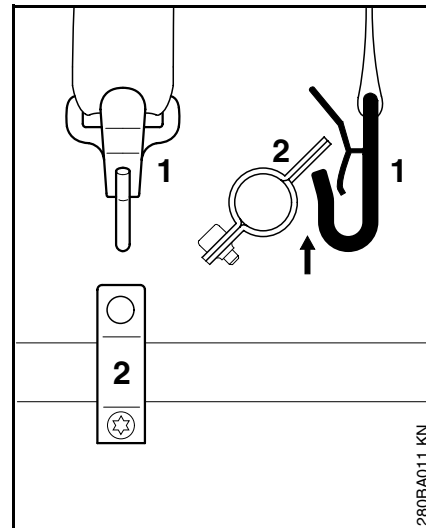

- Attach the spring hook (1) to the clamp (2).

\* see "Guide to Using this Manual"



## Starting

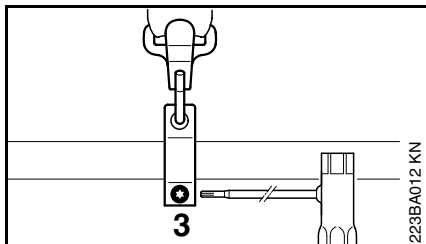

- Loosen the screw (3).

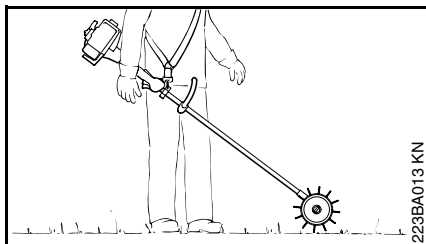

- Slide the clamp up or down the drive tube so that the sweeper belts touch the ground.
- Tighten the screw firmly.

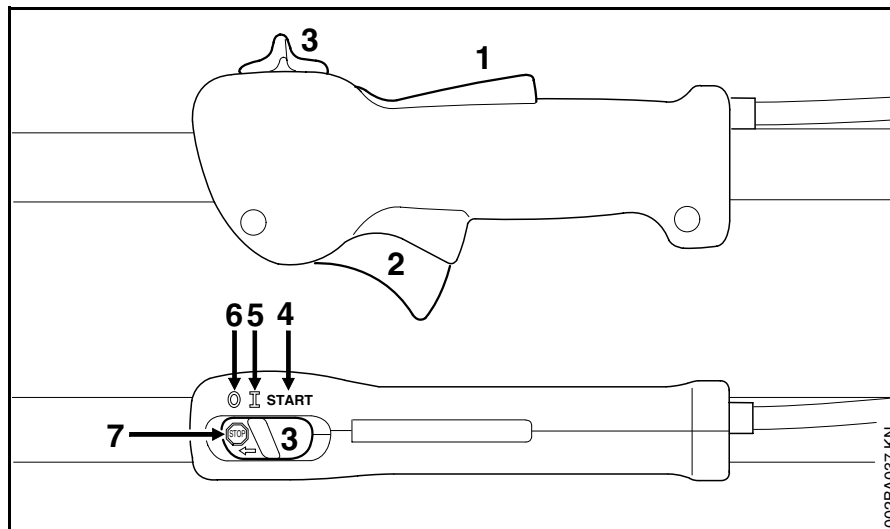

### Controls

Throttle trigger interlock (1), throttle trigger (2) and slide control (3) with positions:

**START** (4),

**I** - normal run position (5), idle position and

**0** - stop (6),  
to stop engine, move slide control in direction of  (7).

### Starting

- Hold down the throttle trigger interlock and squeeze the throttle trigger.
- While holding both levers in this position, move the slide control to **START** and hold it there.
- Now release the throttle trigger, slide control and throttle trigger interlock in that order. This is the **starting throttle position**.

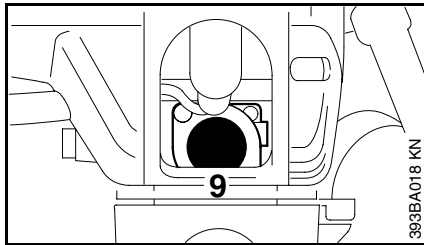
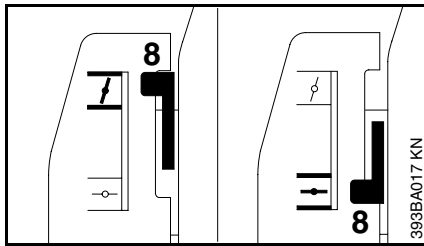

Set the choke lever (8):

for cold start to 

for warm start to  -

(even if engine has been running but is still cold)

- Press fuel pump bulb (9) at least five times.

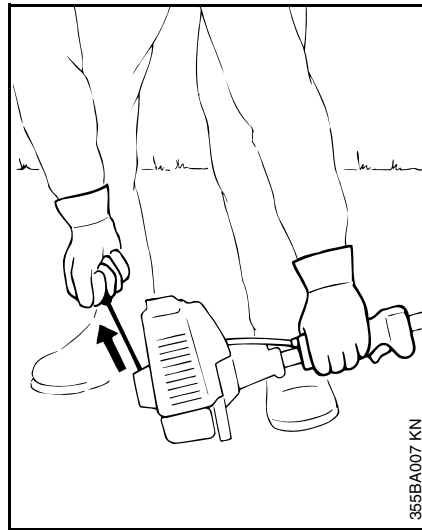

- Hold the unit securely.
- Make sure you have a firm footing.
- Hold the unit with your left hand and press it down **firmly**.

**⚠ If you crank the engine in the "Start" position, the sweeper belts may rotate when the engine starts - this may set the PowerSweep in motion.**

**⚠ Do not stand or kneel on the drive tube!**

- Pull the starter grip slowly with your right hand until you feel it engage and then give it a brisk strong pull. Do not pull out the starter rope all the way - it might otherwise break.
- Do not let the starter grip snap back. Guide it slowly back into the housing so that the starter rope can rewind properly.
- **Continue cranking until engine runs.**

**When the engine begins to fire:**

- Move the choke lever to  and continue cranking.

### As soon as the engine runs:

- Blip the throttle trigger - the slide control moves to the run position **I** - and the engine settles down to idle speed.

Make sure carburetor is correctly adjusted - the sweeper drums must not rotate when engine is idling.

Your machine is now ready for operation.

### To shut down the engine:

- Move the slide control in the direction of  to **0**.

### At very low outside temperatures: Allow the engine to warm up.

As soon as engine runs:

- Blip the throttle trigger to disengage the starting throttle position - the slide control moves to the run position **I** and the engine returns to idling speed.
- Open the throttle slightly.
- Allow engine to warm up for a brief period.

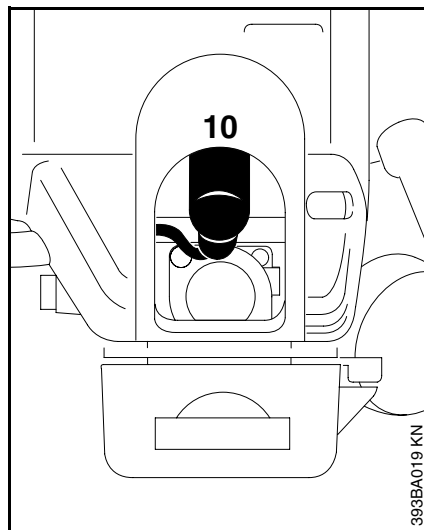



### If the engine does not start:

If you did not move the choke lever to  quickly enough after the engine began to fire, the combustion chamber is flooded.

- Move choke lever to 
- Set slide control, interlock lever and throttle trigger to starting throttle position.
- Crank the engine - pull the starter rope briskly - 10 to 20 pulls may be necessary.

### If the engine still does not start:

- Move the slide control in direction of  to **0**
- Pull off the spark plug boot (**10**).
- Unscrew and dry off the spark plug.
- Open the throttle wide.
- Crank the engine several times with the starter to clear the combustion chamber.
- Refit the spark plug and connect the spark plug boot - push it down firmly.
- Move slide control to **START**.
- Set choke lever to , even if engine is cold.
- Now start the engine.

### Fuel tank run until dry and then refueled

- Press the fuel pump bulb at least five times - even if bulb is filled with fuel.
- Now start the engine.

## Operating Instructions

### During break-in period

A factory new machine should not be run at high revs (full throttle off load) for the first three tank fillings. This avoids unnecessary high loads during the break-in period.

As all moving parts have to bed in during the break-in period, the frictional resistances in the engine are greater during this period. The engine develops its maximum power after about 5 to 15 tank fillings.

### During operation

After a long period of full-throttle operation, allow engine to run for a while at idle speed so that the heat in the engine can be dissipated by flow of cooling air. This protects engine-mounted components (ignition, carburetor) from thermal overload.

### After finishing work

Wait for engine to cool down. Drain the fuel tank. Store the machine in a dry place. Check tightness of nuts and screws (not adjusting screws) at regular intervals and retighten as necessary.

## Using the PowerSweep

Use the PowerSweep for sweeping sand, stones, gravel, leaves and snow on grass, concrete or asphalt and removing standing water from solid surfaces.

- To reduce risk of accidents or injury, remove all obstacles and objects from the work area.
- If the work area is very dry, spray it with water if necessary to reduce the amount of dust created.
- Push the PowerSweep steadily at walking pace.

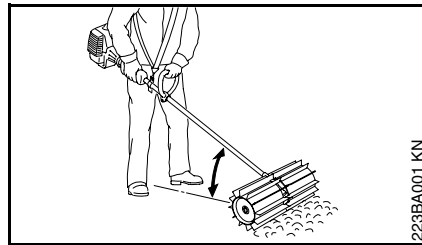

- Always keep the drive tube at a shallow angle (see illustration).
- ⚠ The steeper the angle between the drive tube and the ground, the more difficult it is to control the PowerSweep.

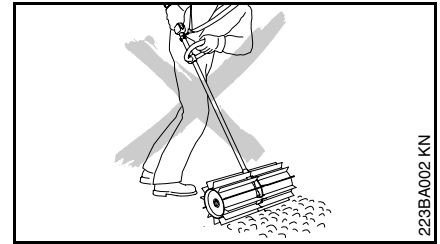

- Do not push the PowerSweep into the ground.

### Sweeping narrow areas

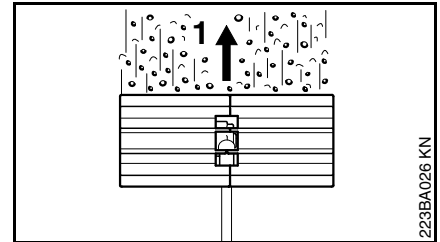

- Guide the sweeper drum at right angles to the direction of travel (1).

Sweepings are thrown forwards, ahead of the operator.

- ⚠ The PowerSweep pushes back toward the operator.

## Disconnecting Machine from Harness

### Sweeping wide areas

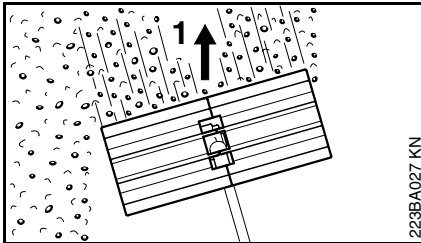

- Guide the sweeper drum at an angle to the direction of travel (1).

Sweepings are thrown forwards to one side.

- ⚠ The PowerSweep pushes back toward the operator.

### Sweeping corners

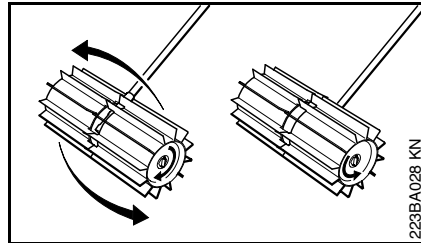

- Turn the PowerSweep over.

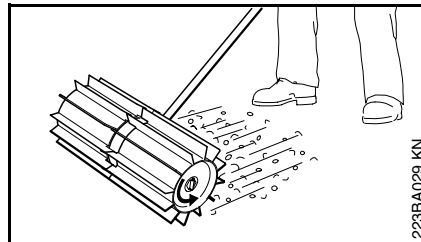

Sweepings are thrown back toward the operator. For this reason:

- Run the PowerSweep at a low throttle setting only.
- ⚠ The PowerSweep pulls the operator forward.
- ⚠ Debris thrown back toward the operator may affect footing.

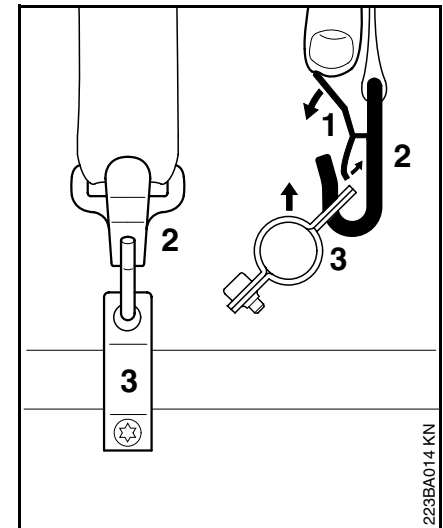

- Press down bar (1) on spring hook (2).
- Pull the clamp (3) out of the spring hook.

\* see chapter "Special Accessories"

## Cleaning the Air Filter

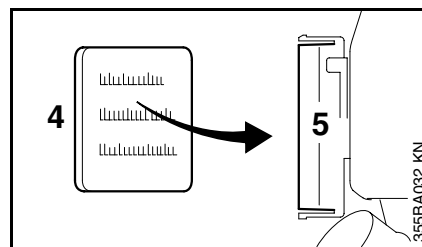
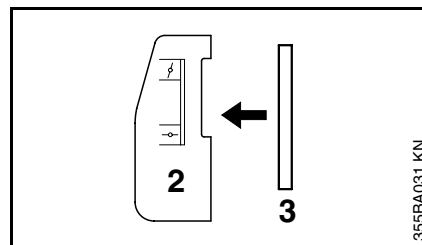
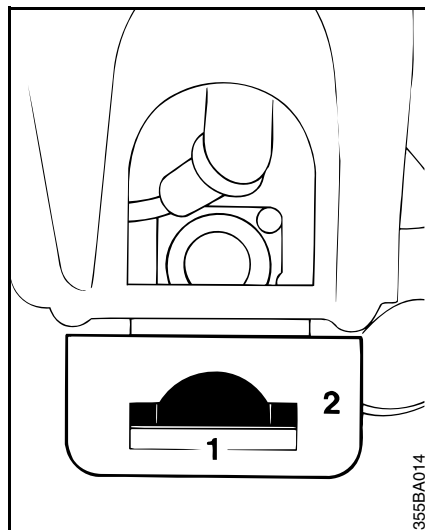

Dirty air filters reduce engine power increase fuel consumption and make starting more difficult.

### If there is a noticeable loss of engine power

- Move choke lever to  $\overline{I}$
- Press in the tab (1).
- Ease the filter cover (2) over the tab and take it away.
- Clean away loose dirt from around the filter.
- Remove the foam and felt filter elements.

- Wash the foam element in a clean, non-flammable cleaning solution (e.g. warm soapy water) and then dry.
- Fit new felt element. As a temporary measure you can knock it out on the palm of your hand or blow it out with compressed air. **Do not wash.**

Replace damaged parts.

- Install the foam element (3) in the filter cover (2).
- Place felt element (4) (lettering facing inward) in filter housing (5).
- Fit filter cover so that it snaps into position.

## Motor Management

Exhaust emissions are controlled by the design of the fundamental engine parameters and components (e.g. carburation, ignition, timing and valve or port timing) without the addition of any major hardware.

## Adjusting the Carburetor

with idle speed screw (**LD**)

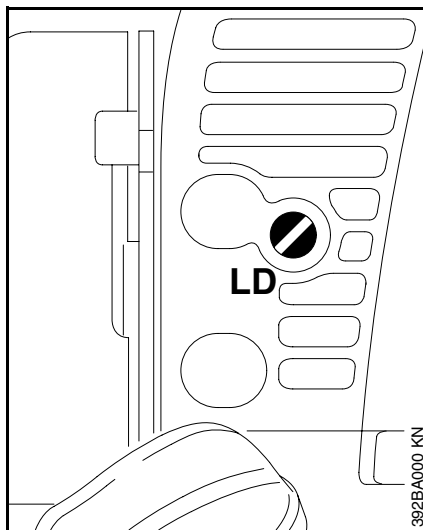

**The carburetor is set at the factory to provide an optimum fuel-air mixture under all operating conditions.**

### Standard setting

- Mount the sweeper drum assemblies.
- Check spark arresting screen\* and clean or replace as necessary.
- Check the air filter and replace as necessary.
- Carefully screw the idle speed screw (**LD**) down onto its seat counterclockwise (left-hand thread). Then open it **two full turns** clockwise (standard setting).

\* see chapter "Key to Symbols"

\* see chapter "Key to Symbols"



## Adjusting the Carburetor with Idle Speed Screw LA

### Adjusting idle speed

- Carry out standard setting.
- Start the engine and allow it to warm up.

### Engine stops while idling:

- Turn the idle speed screw (**LD**) slowly clockwise until the engine runs smoothly - the sweeper drums must not rotate.

### Sweeper drums rotate when engine is idling:

- Turn the idle speed screw (**LD**) counterclockwise until the sweeper drums stop rotating - then turn the screw about another full turn in the same direction from that position.

### Erratic idling behavior, poor acceleration:

- Turn the idle speed screw (**LD**) slowly counterclockwise no more than one half turn.

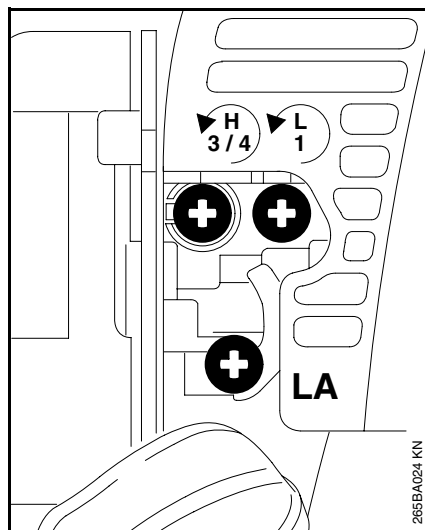

The carburetor comes from the factory with a standard setting.

This setting provides an optimum fuel-air mixture under most operating conditions.

With this carburetor it is only possible to adjust the engine idle speed within fine limits.

### Standard Setting

- Mount the sweeper drum assembly and make sure it is in good condition.
- Check spark arresting screen\* and clean or replace as necessary.
- Check the air filter and replace if necessary.
- Turn high speed screw (**H**) counterclockwise (**max.  $\frac{3}{4}$  turn**) as far as stop.
- Carefully screw the low speed screw (**L**) down onto its seat. Then open it **one** turn counterclockwise.
- Start the engine and allow it to warm up as necessary.
- Adjust idle speed with the idle speed screw (**LA**) so that the sweeper drum does not rotate.

### Fine Tuning

A slight correction of the high speed screw (**H**) may be necessary if engine power is unsatisfactory when working at high altitudes or at sea level.

\* see "Guide to Using this Manual"

- Carry out the standard setting.
- Run the PowerSweep for about 3 to 5 minutes to warm up the engine.

#### **Rule of thumb**

Turn the high speed screw (**H**) about 1 to 2 notches for every 1000 meter change in altitude,

- Open the throttle wide.

#### **At high altitudes**

- Turn the high speed screw (**H**) clockwise (leaner) no further than stop until there is no noticeable increase in engine speed.

#### **At sea level**

- Turn the high speed screw (**H**) counterclockwise (richer) no further than stop until there is no noticeable increase in engine speed.

 It is possible that maximum engine speed may be reached with the standard setting in each case.

#### **Adjusting Idle Speed**

It is usually necessary to change the setting of the idle speed screw (**LA**) after every correction to the low speed screw (**L**).

- Warm up engine.

#### **Engine stops while idling**

- Turn idle speed screw (**LA**) slowly clockwise until the engine runs smoothly – sweeper drum must not rotate.

#### **Sweeper drum rotates when engine is idling**

- Turn idle speed screw (**LA**) slowly counterclockwise until sweeper drum stops rotating and then turn the screw about another  $\frac{1}{2}$  to 1 turn in the same direction.

#### **Erratic idling behavior, engine stops even though setting of LA screw is correct, poor acceleration**

##### **Idle setting too lean:**

- Turn low speed screw (**L**) counterclockwise (about  $\frac{1}{4}$  turn) until the engine runs and accelerates smoothly.

#### **Erratic idling behavior**

##### **Idle setting too rich:**

- Turn low speed screw (**L**) clockwise (about  $\frac{1}{4}$  turn) until the engine runs and accelerates smoothly.

## Checking the Spark Plug

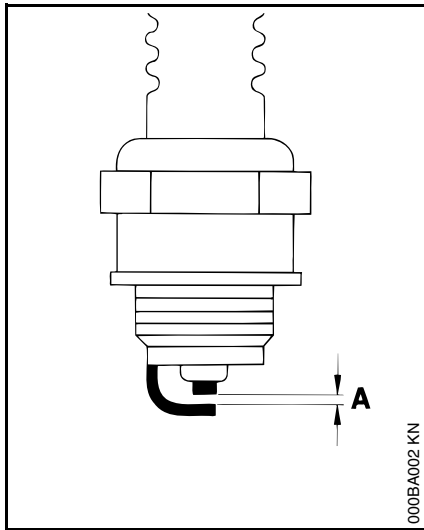

Wrong fuel mix (too much engine oil in the gasoline), a dirty air filter and unfavorable running conditions (mostly at part throttle etc.) affect the condition of the spark plug. These factors cause deposits to form on the insulator nose which may result in trouble in operation.

**If engine is down on power, difficult to start or runs poorly at idling speed, first check the spark plug.**

- Remove spark plug as described in chapter "Starting"
- Clean dirty spark plug.
- Check electrode gap (A) - it should be 0.5mm/0.02" - readjust if necessary.
- Use only resistor type spark plugs of the approved range.

Rectify problems which have caused fouling of spark plug:

- Too much oil in fuel mix.
- Dirty air filter.
- Unfavorable running conditions.

**Fit a new spark plug after approx. 100 operating hours**

or earlier if the electrodes are badly eroded.

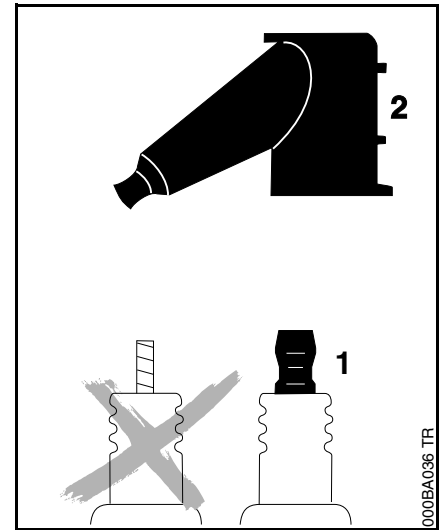

**⚠** To reduce the risk of fire and burn injury, use only spark plugs authorized by STIHL. Always press spark plug boot (2) snugly onto spark plug boot (1) of the proper size. (Note: If boot has detachable SAE adapter nut, it must be attached.) A loose connection between spark plug boot and ignition wire connector in the boot may create arcing that could ignite combustible fumes and cause a fire.

## Removing the Gearbox

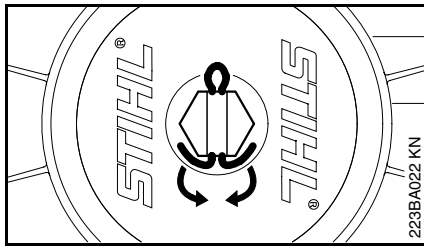

- Straighten the ends of the cotter pin, remove the cotter pin.
- Pull the sweeper drum off the shaft.
- Examine gear housing for signs of oil. If leaks are found, have your STIHL dealer check the gearbox.
- Repeat the above procedure on the other side.

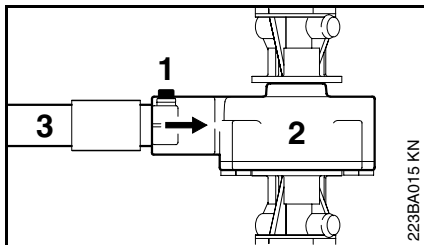

- Release the clamp screw (1).
- Pull the gearbox (2) off the drive tube (3) - turn the gearbox back and forth at the same time to ease removal.

## Replacing the Rubber Sleeve

The rubber sleeve protects the drive tube from wear caused by contact with the sweeper belts. It is fitted on either the drive tube or the gearbox.

A worn sleeve must be replaced as follows:

- Remove the gearbox - see "Removing the Gearbox".

### Sleeve on drive tube

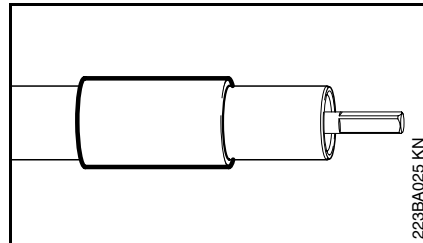

- Remove the worn sleeve from the drive tube. Cut it open with a knife if necessary.

### Sleeve on gearbox

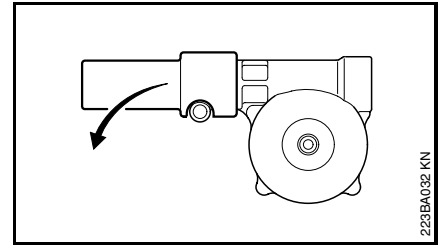

- Pull the worn sleeve off the gearbox.

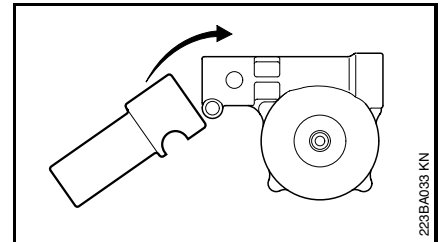

- Push **new sleeve** onto the gearbox.
- Install the gearbox - see "Installing the Gearbox".

## Replacing Sweeper Drum

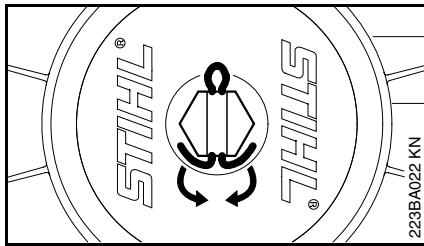

- Straighten the ends of the cotter pin, remove the cotter pin.
- Pull the sweeper drum off the axle.
- Repeat the procedure on the other side.
- Examine gear housing for signs of oil. If leaks are found, have your STIHL dealer check the gearbox.

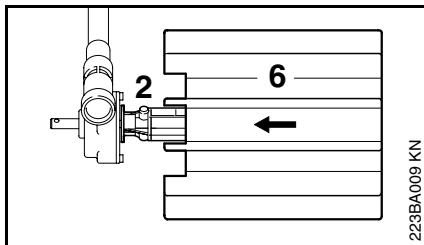

- Push new sweeper drum (6) onto the axle (2).

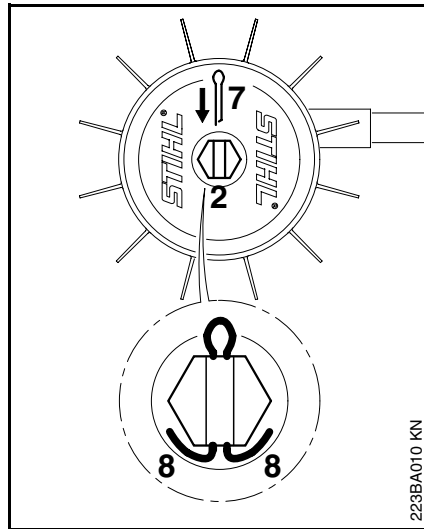

- Fit new cotter pin (7) in end of axle (2) and bend over the ends (8) of the cotter pin as shown.
- Repeat the procedure on the other side.
- Always replace sweeper drum assemblies in pairs.

## Replacing the Starter Rope and Rewind Spring

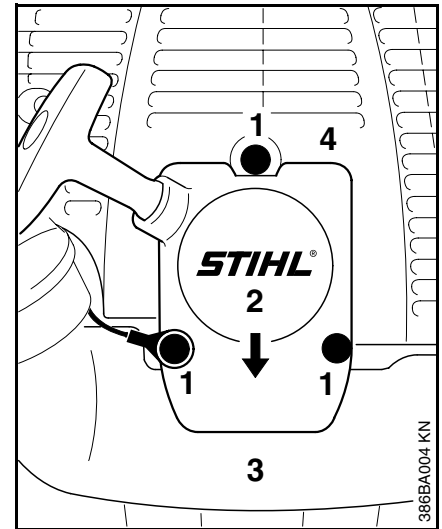

- Take out the screws (1).
- Remove the cable lug.
- Lift the starter cover (2) away from the tank (3) and pull it out from under the shroud (4).

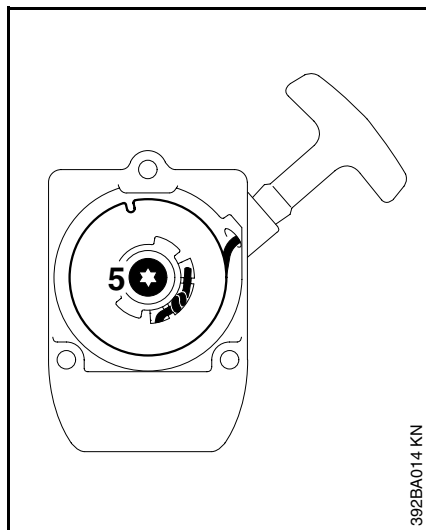

- Take out the screw (5).
- Remove the rope rotor very carefully – the rewind spring is seated in the rope rotor and may pop out and uncoil if care is not taken.

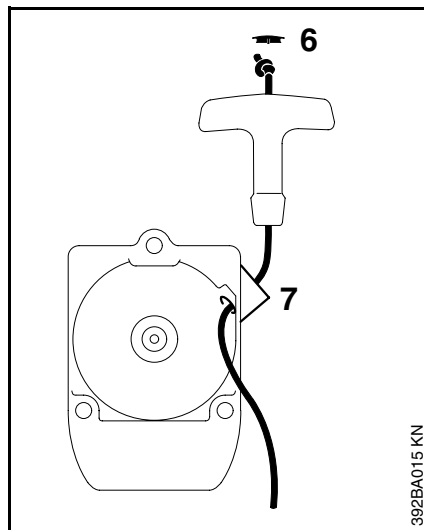

- Use a screwdriver to ease the cap (6) out of the starter grip.
- Remove remaining rope from the rotor and grip, making sure the ElastoStart sleeve is not pushed out of the grip.
- Tie a simple overhand knot in the end of the new starter rope and then thread the rope through the top of the grip and the rope bush (7).
- Refit the cap in the grip.

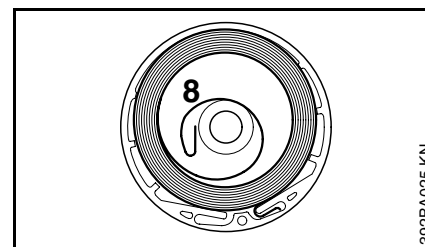
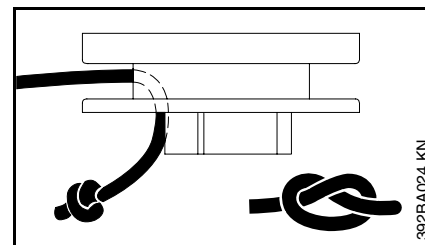

- Pull the rope through the rotor and secure it with a simple overhand knot.
- Coat rope rotor bearing bore with non-resinous oil\*\*.
- Slide rotor onto starter post – turn it back and forth until the rewind spring anchor loop (8) engages.
- Insert screw and tighten down securely.  
Go to "Tensioning the rewind spring".

\*\* see "Special Accessories"

## Replacing a broken rewind spring

- Lubricate the new spring with a few drops of non-resinous oil\*\*, do not open the wire retainer
- Remove the rope rotor.
- Remove parts of old spring.
- Fit the new spring – position outer spring loop in the recess – the wire retainer slips off in this process.

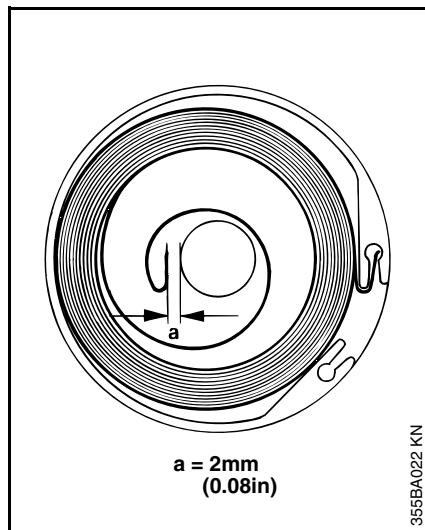

If the spring has popped out:  
Refit it in the counterclockwise direction – starting outside and working inward.

- Install the rope rotor.
- Check dimension "a" on inner spring loop and bend it to size if necessary.
- Go to "Tensioning the rewind spring".

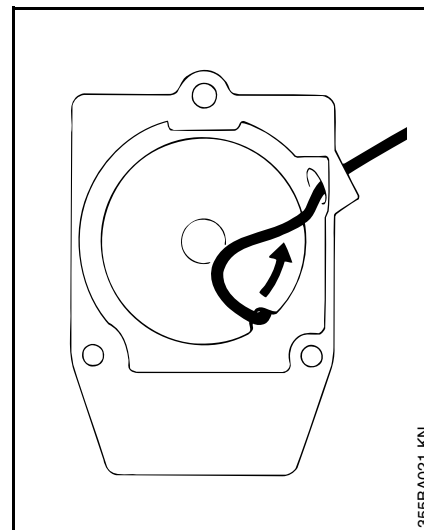

## Tensioning the rewind spring

- Make a loop in the unwound starter rope and use it to turn the rope rotor six full revolutions counterclockwise. Hold the rotor steady – straighten the twisted rope – release the rotor – let go of rope slowly so that it winds onto the rotor.

\*\* see "Special Accessories"



## Spark Arresting Screen in Muffler

The starter grip must be firmly seated in the rope guide bush.  
If grip droops to one side:  
Add one more turn on rope rotor to increase spring tension.

- When the starter rope is fully extended it must be possible to rotate the rotor another half turn. If this is not the case, the spring is overtensioned and could break. Take one turn of rope off the rotor.

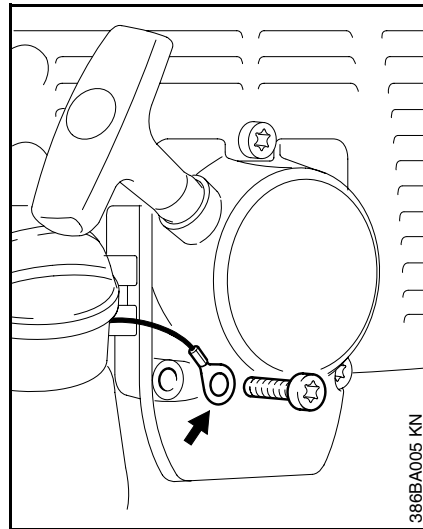

- Fit the starter cover.  
To do this, push the upper mounting boss under the shroud – line up the tank and push lower part of cover onto the tank.
- Insert and tighten down the housing screws.

 Secure cable lug in position.

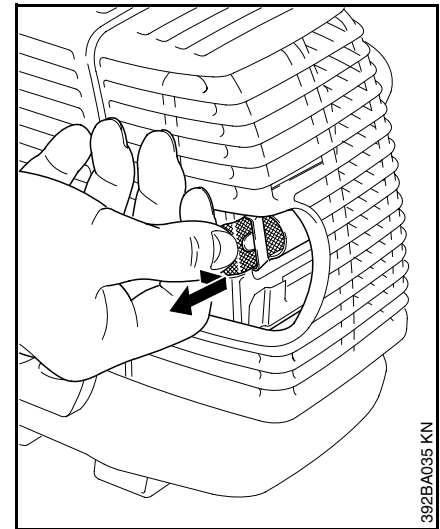

If the engine is low on power, check the spark arresting screen\* in the muffler.

- Lift spark arresting screen and pull it out sideways.
- Clean spark arresting screen if necessary.
- If screen is damaged or coked up, fit a new one.
- Refit the spark arresting screen.

\* see “Guide to Using this Manual”

## Engine Running Behavior

If engine running behavior is unsatisfactory even though the air filter is clean and the carburetor properly adjusted, the cause may be in the muffler.

Have the muffler checked for contamination (coking) by a STIHL dealer.

## Storing the Machine

### **For periods of about 3 months or longer**

- Drain and clean the fuel tank in a well ventilated area.
- Run engine until carburetor is dry - this helps prevent carburetor diaphragms sticking together.
- Remove and clean the sweeper drums, inspect belts for damage or wear.
- Thoroughly clean the machine - pay special attention to the cylinder fins and air filter.
- Store the machine in a dry, high or locked location - out of the reach of children and other unauthorized persons.

## Maintenance Chart

The following maintenance intervals apply to normal operating conditions. If your daily working time is longer than normal or operating conditions are difficult (very dusty work area, etc.), shorten the specified intervals accordingly.		before starting work	after finishing work or daily	after each refueling stop	weekly	monthly	if problem	if damaged	as required
Complete machine	Visual inspection (condition, leaks)	X		X					
	Clean		X						
Control handle	Check operation	X		X					
Air filter	Clean						X		X
	Replace							X	
Filter in fuel tank	Check						X		
	Replace							X	X
Fuel tank	Clean						X		X
Carburetor	Check idle adjustment - sweeper belts must not rotate	X		X					
	Readjust idle								X
Spark plug	Readjust electrode gap						X		
Colling air intakes	Inspect		X						
	Clean								X
Spark arresting screen in muffler	Inspect		X				X		
	Clean or replace							X	X
All accessible screws and nuts (not adjusting screws)	Retighten								X
Rubber buffers	Have replaced by STIHL dealer						X		
Sweeper drum assemblies	Check	X	X	X					
	Replace							X	X
Drive shaft	Check					X			X
	Lubricate								X
Sleeve (drive tube protector)	Check	X	X	X					
	Replace							X	



## Parts and Controls

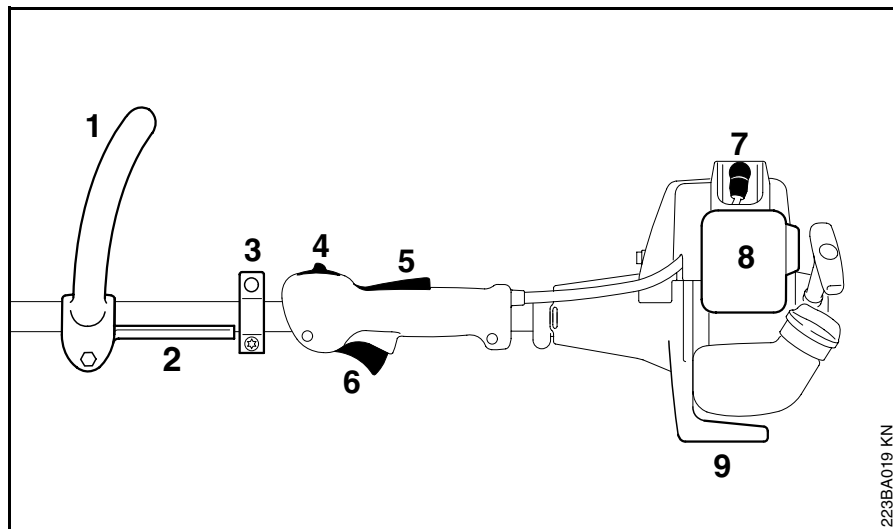

- 1 Loop handle
- 2 Spacer
- 3 Clamp (carrying ring)
- 4 Slide control
- 5 Throttle trigger interlock
- 6 Throttle trigger
- 7 Spark plug boot
- 8 Air filter cover
- 9 Machine support

223BA019 KN

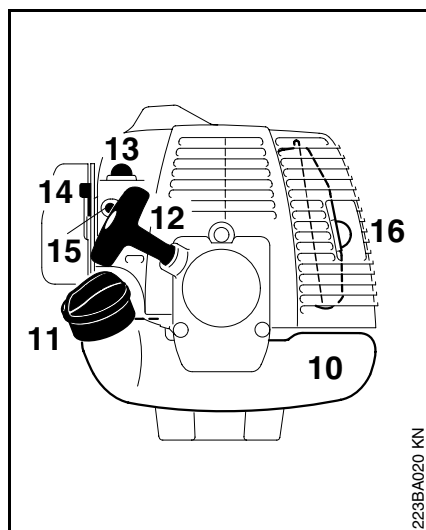

- 10 Fuel tank
- 11 Fuel filler cap
- 12 Starter grip
- 13 Fuel pump (primer bulb)
- 14 Choke lever
- 15 Carburetor adjusting screw
- 16 Muffler (with spark arresting screen in some markets)
- 17 Shaft
- 18 Sleeve (shaft protector)
- 19 Sweeper drum assembly
- 20 Axle
- 21 Gearbox

223BA020 KN

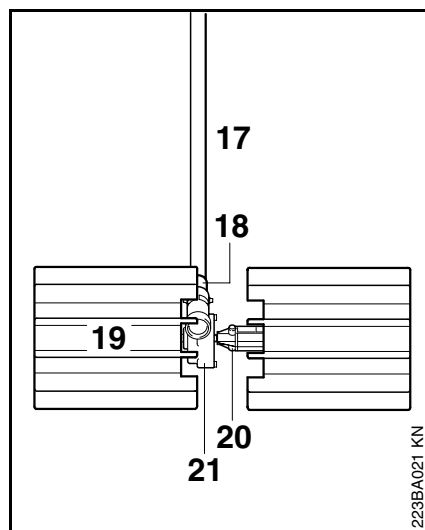

223BA021 KN

## Definitions

- 1. Loop handle.**  
For control of machine.
- 2. Spacer.**  
Maintains minimum distance between left and right hands during operation.
- 3. Clamp (carrying ring).**  
The device to connect the power sweep to the harness.
- 4. Slide control / Stop switch.**  
Starting throttle lock, run and stop switch. Keeps the throttle partially open during starting. The stop switch switches the engine's ignition off and stops the running engine.
- 5. Throttle trigger interlock.**  
Must be depressed before the throttle trigger can be activated.
- 6. Throttle trigger.**  
Controls the speed of the engine.
- 7. Spark plug boot.**  
Connects the spark plug to the ignition wire.
- 8. Air filter cover.**  
Covers the air filter element.
- 9. Machine support.**  
For resting machine on the ground.
- 10. Fuel tank.**  
For fuel and oil mixture.
- 11. Fuel filler cap.**  
For closing the fuel tank.
- 12. Starter grip.**  
The grip of the pull starter, which is the device to start the engine.
- 13. Fuel pump (primer bulb).**  
Provides manual fuel feed for a cold start.
- 14. Choke lever.**  
Eases cold engine starting by enriching mixture.
- 15. Carburetor adjusting screw.**  
For tuning carburetor.
- 16. Muffler (with spark arresting screen).**  
Attenuates exhaust noises and diverts exhaust gases away from operator. The spark arresting screen is designed to reduce the risk of fire.
- 17. Shaft.**  
Device to connect the engine with the gearbox.
- 18. Sleeve (shaft protector).**  
Designed to protect the shaft against abrasion from the sweeper flaps.
- 19. Sweeper drum assembly.**  
Tool for sweeping and cleaning.
- 20. Axle.**  
Connects sweeper drum assembly with the drive shaft.
- 21. Gearbox.**  
To transform the engine speed down to lower RPM of the sweeper drums.

## Specifications

### Engine

Single cylinder two-stroke engine	
Displacement:	1.55cu.in (25.4cc)
Bore:	1.34in (34mm)
Stroke:	1.10in (28mm)
Engine power to	
ISO 8893:	0.95kW (1.3bhp)
Idle speed:	2800rpm
Max. drum	
speed:	approx. 200rpm

### Ignition System

Type:	Electronic magneto ignition
Spark plug (suppressed):	Bosch WSR 6 F, NGK BPMR 7 A or Champion RCJ 6Y *
Electrode gap:	0.02in (0.5mm)
Spark plug thread:	M 14 x 1.25; 0.37in (9.5mm) long

### Fuel System

Carburetor:	All position diaphragm carburetor with integral fuel pump
Air filter:	Foam and felt elements
Fuel tank capacity:	15fl.oz (0.44 l)
Fuel mix:	see "Fuel"

### Weight

without drum assemblies	19.6lbs (8.9kg)
----------------------------	-----------------

### Sweeper Drum

Quantity	2
Width	22.4in (57cm)
No. of rubber paddles	12

\* see chapter "Key to Symbols"

## Special Accessories

STIHL gear lubricant for hedge trimmers

2.8oz (80g) tube    0781 120 1109

8oz (225g) tube    0781 120 1110

## Maintenance and Repairs

The user of this unit should carry out only the maintenance operations described in this manual. Other repair work may be performed only by an authorized STIHL dealer.

Warranty claims following repairs can be accepted only if the repair has been performed by an authorized STIHL dealer using original STIHL replacement parts.

Original STIHL parts can be identified by the STIHL part number, the **STIHL** logo and the STIHL parts symbol . The symbol may appear alone on small parts.



## STIHL Incorporated Federal and California Emission Control Warranty Statement

### Your Warranty Rights and Obligations

The U.S. Environmental Protection Agency (EPA), the California Air Resources Board (CARB) and STIHL Incorporated are pleased to explain the Emission Control System Warranty on your model year 2000 and later equipment type engine. In California, new small off-road engines must be designed, built and equipped to meet the State's stringent anti-smog standards. In other states, new 1997 and later model year small off-road equipment engines must be designed, built and equipped, at the time of sale, to meet the U.S. EPA regulations for small non road engines. The equipment engine must be free from defects in materials and workmanship which cause it to fail to conform with U.S. EPA standards for the first two years of engine use from the date of sale to the ultimate purchaser.

STIHL Incorporated must warrant the emission control system on your small off-road engine for the period of time listed below provided there has been no abuse, neglect or improper maintenance of your small off-road equipment engine.

Your emission control system includes parts such as the carburetor and the ignition system. Also included may be hoses, and connectors and other emission related assemblies.

Where a warrantable condition exists, STIHL Incorporated will repair your small off-road equipment engine at no cost to you, including diagnosis (if the diagnostic work is performed at an authorized dealer), parts, and labor.

### Manufacturer's Warranty Coverage:

The small off-road equipment engines are warranted for two years in California. In other states, 1997 and later model year small off-road equipment engines are also warranted for two years. If any emission-related part on your engine is defective, the part will be repaired or replaced by STIHL Incorporated free of charge.

### Owner's Warranty Responsibilities:

As the small off-road equipment engine owner, you are responsible for the performance of the required maintenance listed in your owner's manual. STIHL Incorporated recommends that you retain all receipts covering maintenance on your small off-road equipment engine, but STIHL Incorporated cannot deny warranty solely for the lack of receipts or for your failure to ensure the performance of all scheduled maintenance.

Any replacement part or service that is equivalent in performance and durability may be used in non-warranty maintenance or repairs, and shall not reduce the warranty obligations of the engine manufacturer.

As the small off-road equipment engine owner, you should be aware, however, that STIHL Incorporated may deny your warranty coverage if your small off-road equipment engine or a part has failed due to abuse, neglect, improper maintenance or unapproved modifications.

You are responsible for presenting your small off-road equipment engine to a STIHL service center as soon as a problem exists. The warranty repairs will be completed in a reasonable amount of time, not to exceed 30 days. If you have any questions regarding your warranty rights and responsibilities, please contact a STIHL customer service representative at 1-800-467-8445 or you can write to STIHL Inc., 536 Viking Drive, P.O. Box 2015, Virginia Beach, VA 23450-2015.

### Coverage by STIHL Incorporated

STIHL Incorporated warrants to the ultimate purchaser and each subsequent purchaser that your small off-road equipment engine will be designed, built and equipped, at the time of sale, to meet all applicable regulations. STIHL Incorporated also warrants to the initial purchaser and each subsequent purchaser that your engine is free from defects in materials and workmanship which cause the engine to fail to conform with applicable regulations for a period of two years.

## Warranty Period

The warranty periods will begin on the date the utility equipment engine is purchased by the initial purchaser and you have signed and sent back the warranty card to STIHL. If any emission related part on your engine is defective, the part will be replaced by STIHL Incorporated at no cost to the owner. Any warranted part which is not scheduled for replacement as required maintenance, or which is scheduled only for regular inspection to the effect of "repair or replace as necessary" will be warranted for the warranty period. Any warranted part which is scheduled for replacement as required maintenance will be warranted for the period of time up to the first scheduled replacement point for that part.

## Diagnosis

You, as the owner, shall not be charged for diagnostic labor which leads to the determination that a warranted part is defective. However, if you claim warranty for a component and the machine is tested as non-defective, STIHL Incorporated will charge you for the cost of the emission test. Mechanical diagnostic work will be performed at an authorized STIHL servicing dealer. Emission test may be performed either at STIHL Incorporated or at any independent test laboratory.

## Warranty Work

STIHL Incorporated shall remedy warranty defects at any authorized STIHL servicing dealer or warranty station. Any such work shall be free of charge to the owner if it is determined that a warranted part is defective. Any manufacturer-approved or equivalent replacement part may be used for any warranty maintenance or repairs on emission-related parts and must be provided without charge to the owner. STIHL Incorporated is liable for damages to other engine components caused by the failure of a warranted part still under warranty.

The California Air Resources Board's Emission Warranty Parts List specifically defines the emission-related warranted parts. These warranted parts are:

Carburetor  
Choke (Cold start enrichment system)  
Intake manifold  
Air filter  
Spark plug  
Magneto or electronic ignition system (ignition module)  
Catalytic converter (if applicable)  
Fasteners

## Where to make a claim for Warranty Service

Bring the product to any authorized STIHL servicing dealer and present the signed warranty card.

## Maintenance Requirements

The maintenance instructions in this manual are based on the application of the recommended 2-stroke fuel-oil mixture (see also instruction "Fuel"). Deviations from this recommendation regarding quality and mixing ratio of fuel and oil may require shorter maintenance intervals.

## Limitations

This Emission Control Systems Warranty shall not cover any of the following:

- repair or replacement required because of misuse, neglect or lack of required maintenance,
  - repairs improperly performed or replacements not conforming to STIHL Incorporated specifications that adversely affect performance and/or durability, and alterations or modifications not recommended or approved in writing by STIHL Incorporated,
- and
- replacement of parts and other services and adjustments necessary for required maintenance at and after the first scheduled replacement point.

## Quality Certification



All STIHL products comply with the highest quality standards.

An independent organization has certified that all products manufactured by STIHL meet the strict requirements of the ISO 9001 standard for quality management systems in terms of product development, materials purchasing, production, assembly, documentation and customer service.



## **WARNING!**

The engine exhaust from this product contains chemicals known to the State of California to cause cancer, birth defects or other reproductive harm.

0458 223 3021

englisch / english USA / CARB / EPA