

STIHL FS 66

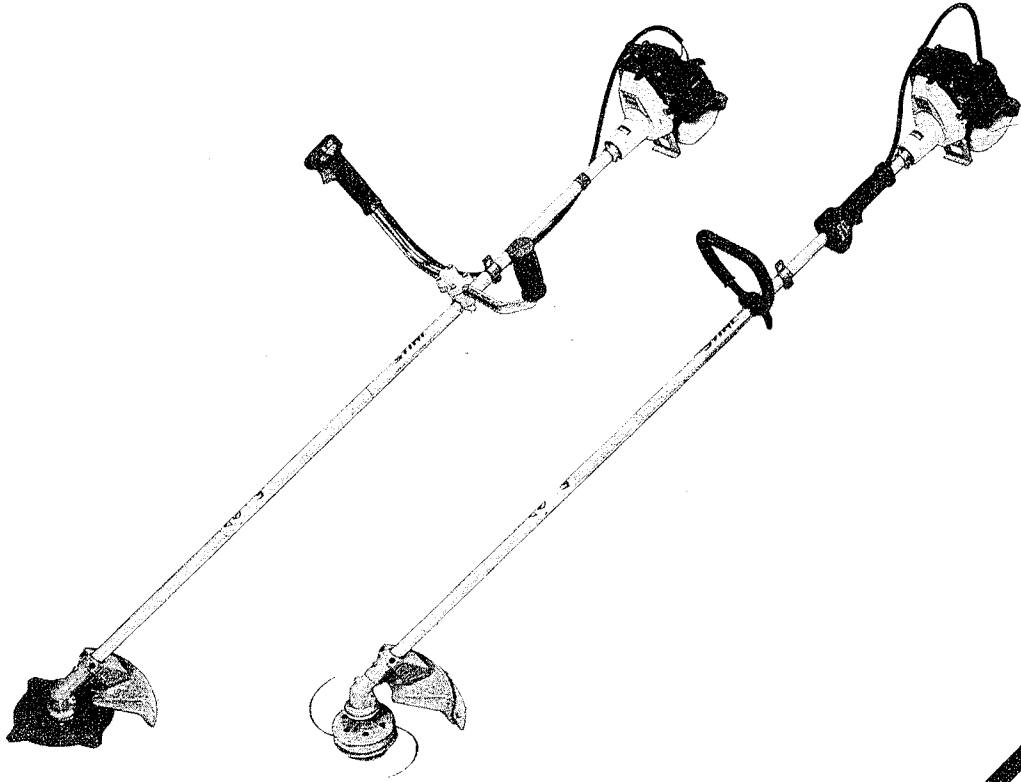

Warning:
Always follow safety precautions in
Owner's Manual – improper use
can cause serious injury!

STIHL FS 66, FS 66 R

This manual contains operating and safety instructions for all versions of model STIHL FS 66 brushcutters.

Pay special attention to the safety precautions outlined on pages 6 to 15. Allow only persons who understand this manual to operate your brushcutter.

To receive maximum performance and satisfaction from your STIHL brushcutter, it is important that you read and understand the maintenance and safety precautions before using your brushcutter. Contact your STIHL dealer or the STIHL distributor for your area if you do not understand any of the instructions in this manual.

Warning!

Because a brushcutter is a high-speed cutting tool, some special safety precautions must be observed as with any other brushcutter to reduce the risk of personal injury. Careless or improper use may cause serious or even fatal injury.

STIHL's philosophy is to continually improve all of its products. As a result, engineering changes and improvements are made from time-to-time. If the operating characteristics or the appearance of your brushcutter differs from those described in this manual, please contact your STIHL dealer for information and assistance.

Warning!

For safety reasons only the following cutting tools may be fitted and used on brushcutters with a loop handle:

- STIHL "Supercut" mowing head
- STIHL "Polycut" mowing head
- STIHL "Polymatic" mowing head
- Grass cutting blade 230
- Brush knife 250

0458 304 0121, M5. K8 S Printed in Japan

Owner's Manual

Contents

Parts and Controls of FS 66	2
Parts and Controls of FS 66 R	4
Safety Precautions and Working Techniques	6
- The Operator	6
- The Brushcutter	8
- The Use of the Brushcutter	8
- Using the Cutting Tools	11
- Maintenance, Repair and Storing	15
Assembling the Brushcutter	16
Mounting the Cutting Tools	21
STIHL "Supercut 2" Mowing Head	22
STIHL "Polycut 1" Mowing Head	23
STIHL "Polycut 2" Mowing Head	24
STIHL "Polymatic 2" Mowing Head	25
Grass Cutting Blade 230, Brush Knife 250	26
Circular Saw Blade 200 (Scratcher and Chisel Tooth)	27
Fuel	28
Fitting the Harness, Balancing the Brushcutter	29
Notes on Operation	30
Starting	31
Carburetor	34
Air filter	35
Gearbox Lubrication	36
Sharpening Grass Cutting Blade	37
Sharpening the Brush Knife	37
Sharpening the Circular Saw Blade (Scratcher and Chisel Tooth)	38
Rewind Starter	39
Maintenance	42
Specifications	43
Key to Symbols	45

STIHL[®]

Andreas Stihl
Postfach 1771

D-7050 Waiblingen

100813400

Parts and Controls of FS 66

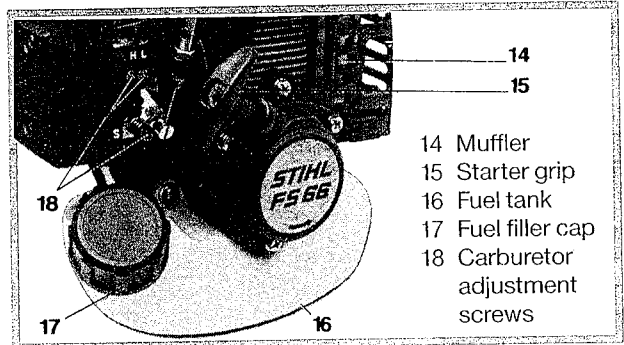
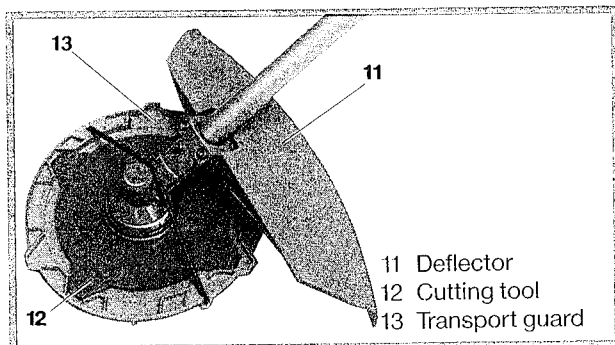
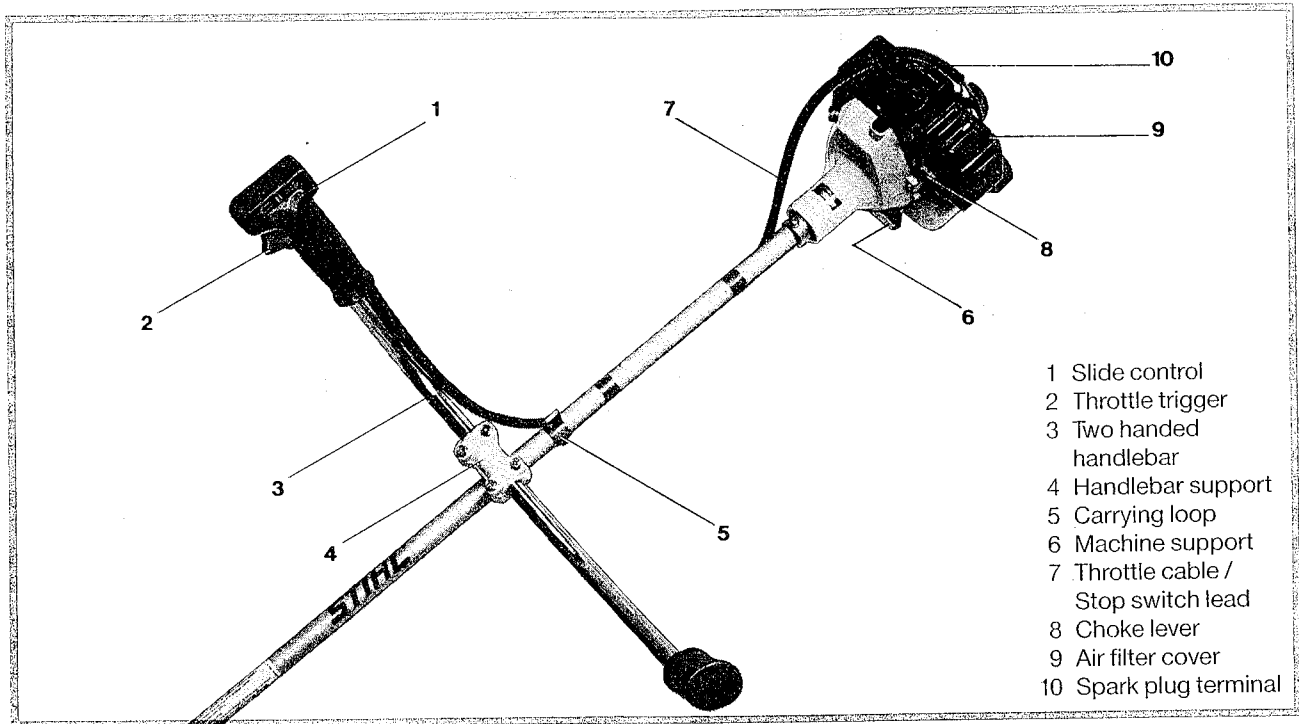

Definitions

1. **Slide control.** Starting throttle lock and stop switch. Keeps the throttle partially open during starting and switches the engine's ignition off and stops the engine.
 2. **Throttle trigger.** Controls the speed of the engine.
 3. **Two handed handlebar.** To hold the brushcutter with both hands.
 4. **Handlebar support.** The device to connect the drive shaft to the handlebars.
 5. **Carrying loop.** The device to connect the brushcutter to the harness.
 6. **Machine support.** For resting machine on the ground.
 7. **Throttle cable/Stop switch lead.** Connect operator's control grip to the powerhead.
 8. **Choke lever.** Eases engine starting by enriching mixture.
 9. **Air filter cover.** Covers the air filter element.
 10. **Spark plug terminal.** Connects the spark plug to the ignition wire.
 11. **Deflector.** The deflector is designed to reduce the risk of injury from foreign objects being thrown back towards the operator by the cutting tool or from operator contact with the cutting tool. The skirt at the bottom of the deflector must be adjusted as described in the chapters on mounting the various cutting tools.
 12. **Cutting tool.** The cutting attachment, i.e. head or blade, made from different materials for different purposes (special accessory).
 13. **Transport guard.** For all metal cutting tools when transporting the brushcutter (special optional accessory).
 14. **Muffler.** Attenuates exhaust noises and diverts exhaust gases away from operator.
 15. **Starter grip.** The grip of the pull starter, which is the device to start the engine.
 16. **Fuel tank.** For fuel and oil mixture.
 17. **Fuel filler cap.** For closing the fuel tank.
 18. **Carburetor adjustment screws.** For tuning carburetor.
- Harness.**
To balance the weight of the brushcutter on the shoulder for a better control of the brushcutter.
(Not illustrated)
- Stop.** Recommended when cutting down small trees with circular saw blade to help the operator keep the brushcutter positioned against the tree during the cutting process.
(Not illustrated)

Parts and Controls of FS 66 R

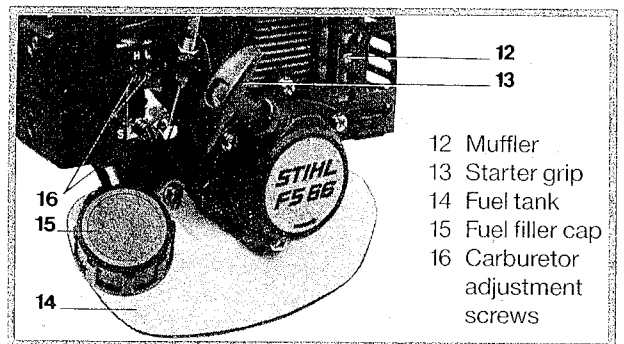
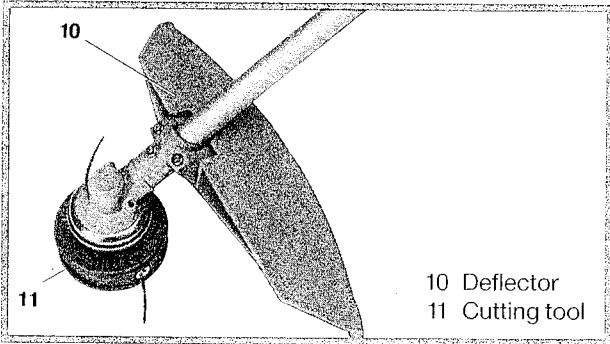
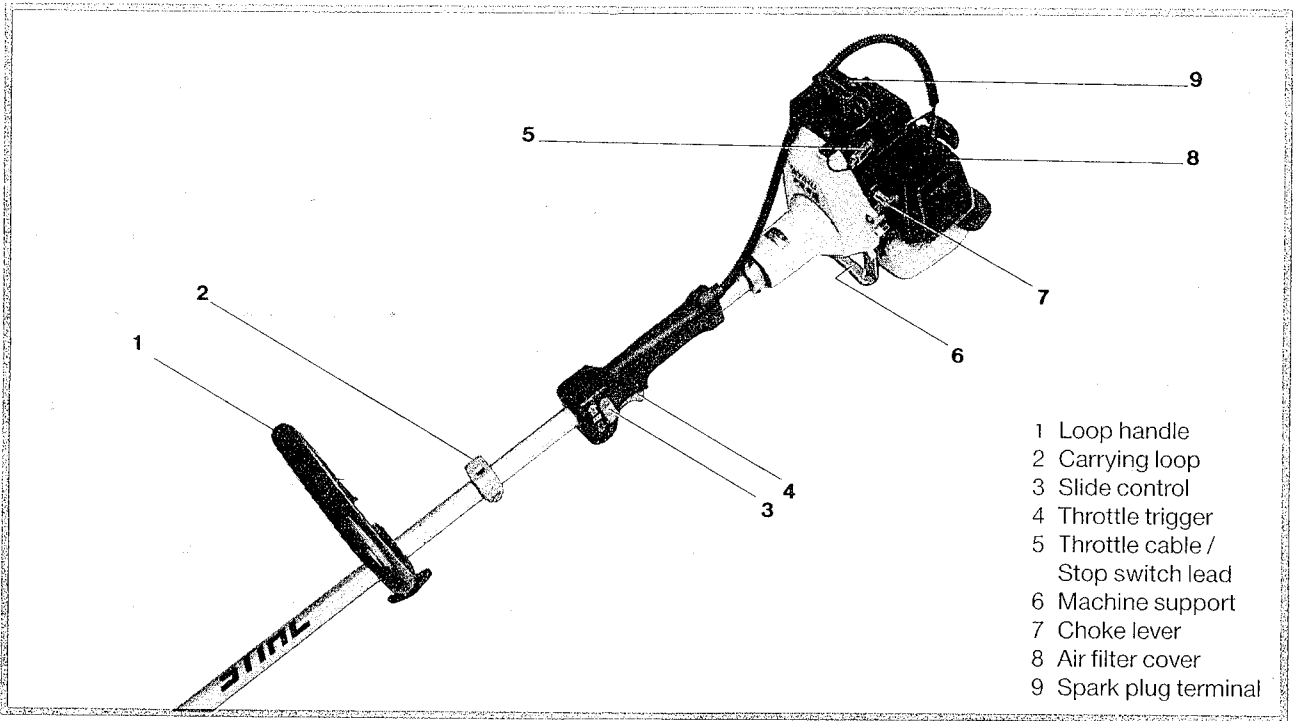

Definitions

1. **Loop handle.** For easy control of machine during cutting work.
2. **Carrying loop.** The device to connect the brushcutter to the harness.
3. **Slide control.** Starting throttle lock and stop switch. Keeps the throttle partially open during starting and switches the engine's ignition off and stops the engine.
4. **Throttle trigger.** Controls the speed of the engine.
5. **Throttle cable/Stop switch lead.** Connect operator's control grip to the powerhead.
6. **Machine support.** For resting machine on the ground.
7. **Choke lever.** Eases engine starting by enriching mixture.
8. **Air filter cover.** Covers the air filter element.
9. **Spark plug terminal.** Connects the spark plug to the ignition wire.
10. **Deflector.** The deflector is designed to reduce the risk of injury from foreign objects being thrown back towards the operator by the cutting tool or from operator contact with the cutting tool. The skirt at the bottom of the deflector must be adjusted as described in the chapters on mounting the various cutting tools.
11. **Cutting tool.** The cutting attachment, i.e. head or blade, made from different materials for different purposes (special accessory).
12. **Muffler.** Attenuates exhaust noises and diverts exhaust gases away from operator.
13. **Starter grip.** The grip of the pull starter, which is the device to start the engine.
14. **Fuel tank.** For fuel and oil mixture.
15. **Fuel filler cap.** For closing the fuel tank.
16. **Carburetor adjustment screws.** For tuning carburetor.

Harness.

To balance the weight of the brushcutter on the shoulder for a better control of the brushcutter.
(Not illustrated)

Warning!

Never use a circular saw blade on a brushcutter with a loop handle, to reduce the risk of serious injury to the operator or bystanders.

Safety Precautions and Working Techniques

Warning!

The use of any brushcutter may be hazardous. If the rotating cutting tool comes in contact with your body, it will cut you. When it comes in contact with solid foreign objects such as rocks or bits of metal, it may fling them directly or by ricochet in the direction of bystanders or the operator.

Striking such objects could damage the cutting attachment and may cause blades to crack, chip or break. STIHL does not recommend the use of rigid blades when cutting in stony areas. Thrown objects or damaged blades may result in serious or fatal injury to the operator or bystanders.

Warning!

Because a brushcutter is a highspeed, fast cutting power tool, special safety precautions must be observed to reduce the risk of personal injury.

It is important that you read, fully understand and observe the following safety precautions and warnings. Read the owner's manual **and** the safety instructions periodically. Careless or improper use of any brushcutter may cause serious or fatal injury.

Have your STIHL dealer show you how to operate your brushcutter. Observe all applicable local safety regulations, standards and ordinances.

Warning!

Minors should never be allowed to use a brushcutter. Bystanders, especially children and animals should not be allowed in the area where a brushcutter is in use (ill. 1).

Never let the brushcutter run unattended.

Do not lend or rent your brushcutter without the owner's manual. Be sure that anyone using your brushcutter understands the information contained in this manual.

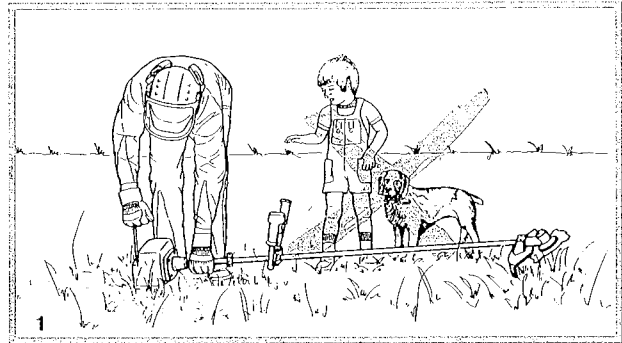

These safety precautions and warnings apply to the use of all STIHL brushcutters. Different models may have different parts and controls. See the appropriate section of your owner's manual for a description of the controls and function of the parts of your model brushcutter.

Safe use of a brushcutter involves

1. the operator
2. the brushcutter
3. the use of the brushcutter.

THE OPERATOR

Physical Condition

You must be in good physical condition and mental health and not under the influence of any substance (drugs, alcohol, etc.) which might impair vision, dexterity or judgment. Do not operate a brushcutter when you are fatigued (ill. 2).

Be alert – if you get tired while operating your brushcutter, take a break. Tiredness may result in loss of control.

Working with any brushcutter can be strenuous. If you have any condition that might be aggravated by strenuous work, check with your doctor before operating a brushcutter.

Prolonged use of a brushcutter (or other machines) exposing the operator to vibrations may produce whitefinger disease (Raynaud's phenomenon). This phenomenon reduces the hand's ability to feel and regulate temperature, produces numbness and burning sensations and may cause nerve and circulation damage and tissue necrosis.

Warning!

Antivibration systems do not guarantee that you will not sustain whitefinger disease. Therefore, continual and regular users should monitor closely the condition of their hands and fingers. If any of the above symptoms appear, seek medical advice immediately.

Proper Clothing

Clothing must be sturdy and snug-fitting, but allow complete freedom of movement. Avoid loose-fitting jackets, scarfs, neckties, jewelry, flared or cuffed pants or anything that could become caught on branches, brush or moving parts of the unit. Wear long pants made of heavy material to protect your legs (ill. 3). Do not wear shorts.

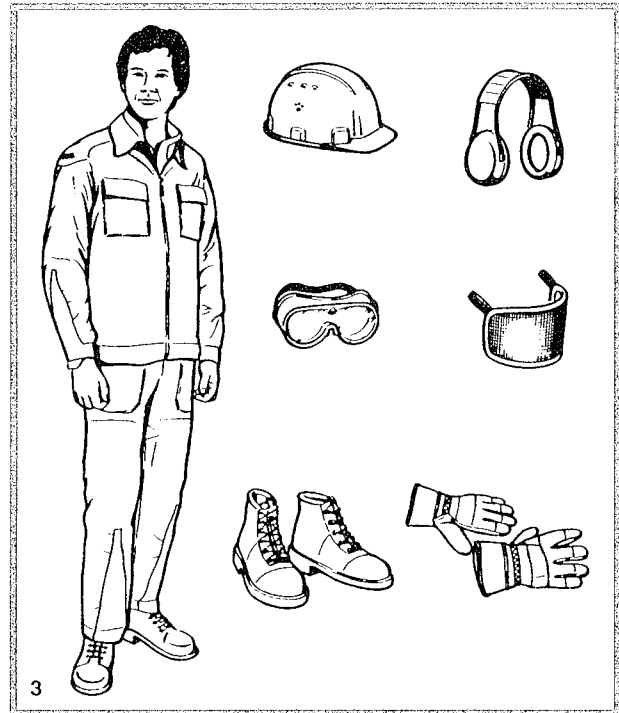

Warning!

Never use a brushcutter without safety goggles or face screen. The deflector provided with your brushcutter may not protect the operator from all foreign objects (gravel, glass, wire, etc.) thrown by the cutting attachment. Foreign objects may also ricochet and strike the operator. Therefore, to reduce the risk of injury, the operator must wear protective clothing including eye protection.

Protect your hands with gloves when handling the brushcutter and the cutting tool. Heavy-duty, nonslip gloves improve your grip and protect your hands.

Good footing is most important in brushcutter work. Wear sturdy boots with nonslip soles. Steel-toed safety boots are recommended.

Wear an approved safety hard hat to protect your head when there is a danger of head injuries.

Brushcutter noise may damage your hearing. Wear sound barriers (ear plugs or ear muffers) to protect your hearing. Continual and regular users should have their hearing checked regularly.

THE BRUSHCUTTER

For illustrations and definitions of the Brushcutter parts see chapter "Parts and Controls of brushcutter"!

Warning!

Never modify a brushcutter in any way. Only attachments supplied by STIHL or expressly approved by STIHL for use with the specific STIHL brushcutter models are authorized. Although certain unauthorized attachments are useable for the STIHL brushcutter, their use may, in fact, be extremely dangerous.

THE USE OF THE BRUSHCUTTER

Transporting the brushcutter

Warning!

Always stop the engine before putting a brushcutter down.

When transporting your brushcutter in a vehicle properly secure it to prevent turnover, fuel spillage and damage to the brushcutter. Keep the cutting tool covered with the transport guard (optional accessory).

Preparation for the use of the brushcutter

8 Adjust harness and hand grip to suit your size before

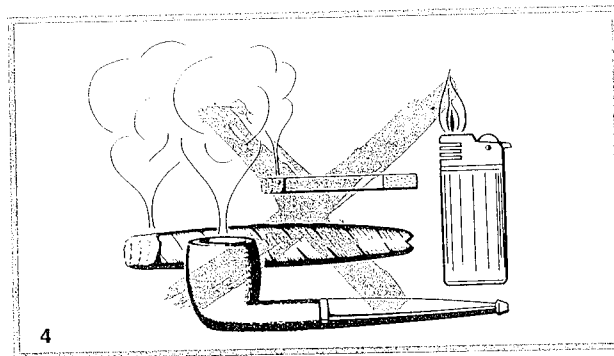

starting work. The machine should be properly balanced as specified in this owner's manual for proper control and less fatigue in operation.

Always check your brushcutter for proper condition and operation before starting, particularly the throttle lever, stop switch, cutting tool, deflector and harness.

The throttle trigger must move freely and always spring back to the idle position. The cutting tool must be properly tightened and in safe operation condition. Inspect for loose parts (nuts, screws, etc.) and for cracked, bent, warped or damaged blades.

Fueling

Your STIHL brushcutter uses an oil-gasoline mixture for fuel (see chapter "Fuel" of your owner's manual).

Warning!

Gasoline is an extremely flammable fuel. Use extreme caution when handling gasoline or fuel mix. Do not smoke or bring any fire or flame near the fuel (ill. 4).

Fueling Instructions

Fuel your brushcutter in well-ventilated areas, outdoors

only. Always shut off the engine and allow it to cool before refueling. Relieve fuel tank pressure by loosening fuel cap slowly. Never remove fuel filler cap while engine is running.

Select bare ground for fueling and move at least 10 feet (3 m) from the fueling spot before starting the engine. Wipe off any spilled fuel before starting your brushcutter and check for leakage.

Check for fuel leakage while refueling and during operation. If fuel or oil leakage is found, do not start or run the engine until leak is fixed and spilled fuel has been wiped away. Take care not to get fuel on your clothing. If this happens, change your clothing immediately.

Starting

Warning!

Your brushcutter is a one-person machine. Once started it may fling foreign objects for a great distance. To reduce the risk of eye and other injury insure that bystanders are at least 30 feet (10 m) away. Start and operate your brushcutter without assistance. For specific starting instructions, see the appropriate section of your manual.

Place the brushcutter on firm ground or other solid surface in an open area. Maintain a good balance and secure footing.

Be absolutely sure that the cutting tool is clear of you and all other obstructions and objects, including the ground, because when the engine starts at starting-throttle, engine speed will be fast enough for the clutch to engage and turn the cutting tool.

When you pull the starter grip, don't wrap the starter rope around your hand. Do not allow the grip to snap back, but guide the starter rope slowly back to permit the rope to rewind properly. Failure to follow this procedure may result in injury to hand or fingers and may damage the starter mechanism.

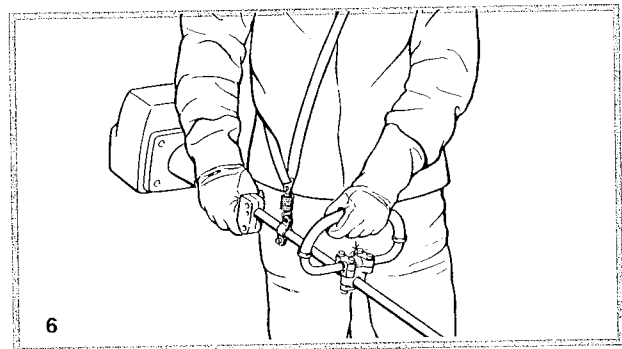
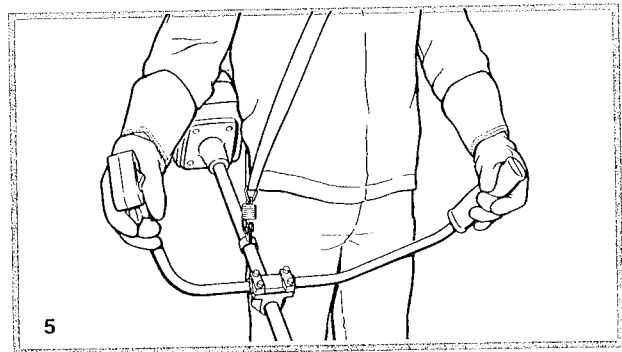

Working Conditions

Operate and start your brushcutter only outdoors in a ventilated area. Operate the brushcutter under good visibility and daylight conditions only. Work carefully.

Always hold the brushcutter firmly with both hands. Wrap your fingers tightly around the handles, keeping the handles cradled between your thumb and forefinger. Keep your hands in this position, to have your brushcutter under control at all times (ill. 5 = with handlebar, ill. 6 = with loop handle). Make sure your brushcutter handles and grip are in good condition and free of moisture, pitch, oil or grease.

Warning!

Never attempt to operate any brushcutter with one hand. Loss of control of the brushcutter resulting in serious or fatal injury may result.

To reduce the risk of bodily injury resulting from loss of control and contact with the cutting tool, always attach and wear harness on those brushcutters equipped with handlebars as well as on those brushcutters equipped with a straight shaft and loop handle.

Special care must be taken in slippery conditions (wet ground, snow) and in difficult, over-grown terrain. Watch for hidden obstacles such as tree stumps, roots and ditches to avoid stumbling. Before cutting inspect the area for stones, glass, pieces of metal, trash or other solid objects. The cutting attachment could throw objects of this kind.

To reduce the risk of injury from thrown objects, keep the skirt on the deflectors adjusted properly at all times (see chapter on mounting the various cutting tools of your owner's manual).

Do not overreach. Keep proper footing and balance at all times.

Warning!

This brushcutter is normally to be used on ground level with the cutting attachment parallel to the ground. Use of a brushcutter above ground level or with the cutting attachment perpendicular to the ground may increase the risk of injury, since the cutting attachment is more fully exposed and the brushcutter may be more difficult to control. Never use your brushcutter as a hedge trimmer.

Warning!

When using rigid blades, avoid cutting close to fences, sides of buildings, tree trunks, stones or other such objects

that could cause the brushcutter to kick out or could cause damage to the blade. STIHL recommends use of the Polymatic nylon line head or Polycut head for such jobs. In addition, be alert to an increased possibility of ricochets in such situations.

Do not operate using the starting throttle lock as you do not have control of the engine speed. See chapter of your owner's manual for the proper use of the starting slide control.

If the cutting tool or deflector becomes clogged or stuck, always turn off the engine before cleaning. Grass, weeds, etc. should be cleaned off the cutting tool at regular intervals.

Warning!

During cutting, check the tightness and the condition of the cutting tool at regular intervals. If the behavior of the tool changes stop the engine immediately and check the nut securing the tool for tightness and the cutting tool for cracks and damage.

Replace cracked, bent, warped, damaged or dull cutting tools immediately. Such tools may shatter at high speed and cause serious or fatal injury.

Warning!

A loose blade may cause the blade to crack, break or come off the brushcutter, which may result in serious or fatal injury. Make sure that the blade is properly tightened. Use the wrench supplied or one of sufficient length to obtain the proper torque. If the blade loosens after being properly tightened, stop work immediately. The retaining nut may be worn or damaged and should be replaced. Never use unauthorized parts to secure the blade. If the blade continues to loosen, see your STIHL dealer. Never use a brushcutter with a loose blade.

Important adjustments

Warning!

At correct idle speed, the cutting tool should not turn. For directions to adjust idle speed, see the appropriate section of your owner's manual.

Do not use a brushcutter with incorrect idle speed adjustment. Adjust the idle speed yourself according to the instructions in your manual. If you cannot set the correct idle speed, have your STIHL dealer check your brushcutter and make proper adjustments or repairs.

Warning!

Never touch a rotating cutting tool with your hand or any part of your body. It continues to rotate for a short period after the throttle trigger is released (flywheel effect).

Do not cut any material other than grass, brush and wood. The cutting tools may be used only for the operations described in your manual.

Operating instructions

With the engine running, attach the brushcutter to the spring hook of your harness (ill. 7).

Warning!

Improper use of any brushcutter/trimmer can cause serious or fatal injury.

To reduce the risk of personal injury:

- never use any metal cutting attachment on a brushcutter that has a flexible shaft and loop handle,
- never use a circular saw blade on a brushcutter that has a straight shaft and loop handle.

Read, understand and follow carefully all safety instructions in your owner's manual before operating these products.



USING THE CUTTING TOOLS

For an illustration of the various cutting tools and instructions on proper mounting see chapter "mounting the cutting tools" in your manual.

Using the mowing heads

The STIHL Supercut, Polymatic and Polycut mowing heads are intended to supplement a lawn mower. They produce a clean and tidy finish.

Top: Lawn edging with the STIHL "Polycut", STIHL "Supercut" or STIHL "Polymatic"
 Bottom: Mowing around trees with the STIHL "Polycut" (with nylon line), STIHL "Polymatic" or STIHL "Supercut"

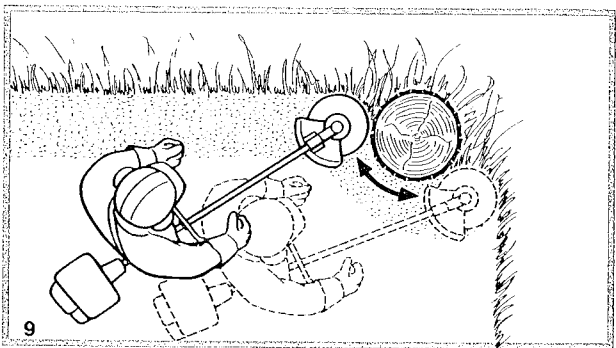
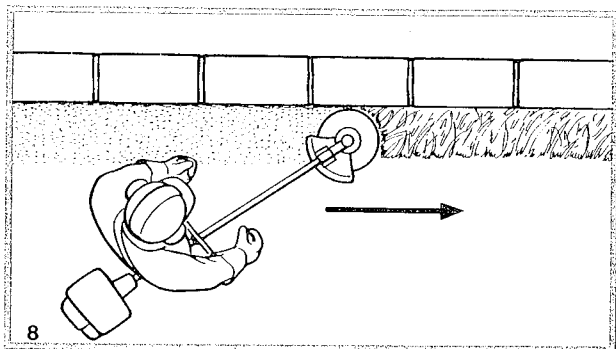

If the lawn edges are planted with trees or bordered by a fence etc., it is best to use a nylon line head. It achieves a "softer" cut with less risk of damaging tree bark than with the polymer blades (ill. 8).

However, the polymer bladed STIHL "Polycut" produces a better cut if there are no plants along the edge of the lawn (ill. 9). Sharpening is not necessary and worn cutting blades are easily replaced.

Warning!

12 Never use wire in place of the nylon cutting lines.

Wear limit marks on Polycut base

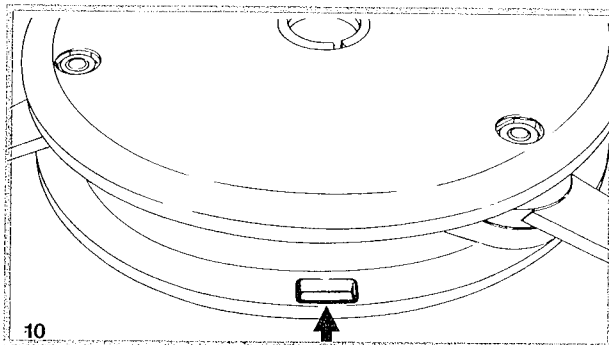

STIHL "Supercut" mowing head

The Supercut mowing head is to be used only on brushcutters equipped with a chopper blade on the deflector.

STIHL "Polymatic" mowing head

Frayed line is replaced by a simple adjustment (see instruction sheet supplied with mowing head).

STIHL "Polycut" mowing head

Important!

Three rectangular wear limit marks are applied to the base (periphery) of the Polycut (ill. 10). The Polycut must not be used when it has as far as one of these marks.

Top: Lawn edging with the STIHL "Supercut"
Bottom: Mowing with grass cutting blade or brush knife

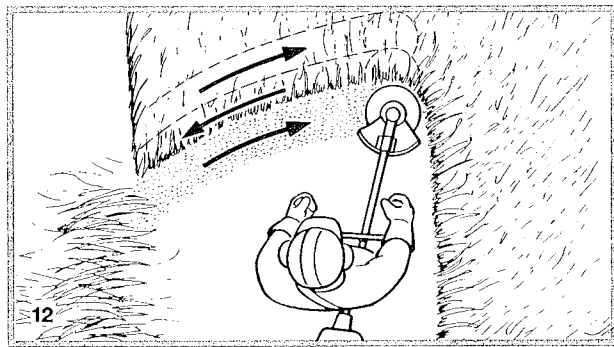
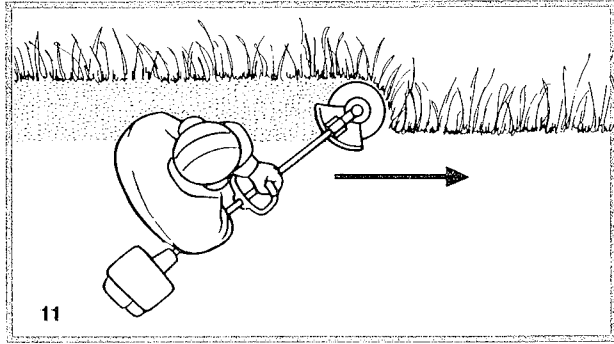

Using the grass cutting blade

All kinds of grass, weeds, small shrubs, small brush, etc. can be easily cut with the grass cutting blade. The brushcutter is swept in an arc similar to a scythe (ill. 12).

The cutting blade has 4 cutting knives which are each equipped with cutting edges on both sides, i.e. front and rear. When the cutting edges become dull on one side the cutting blade need only be turned over and the tool is ready to cut again with 4 fresh cutting edges.

Cutting wild growth and scrub with the brush knife

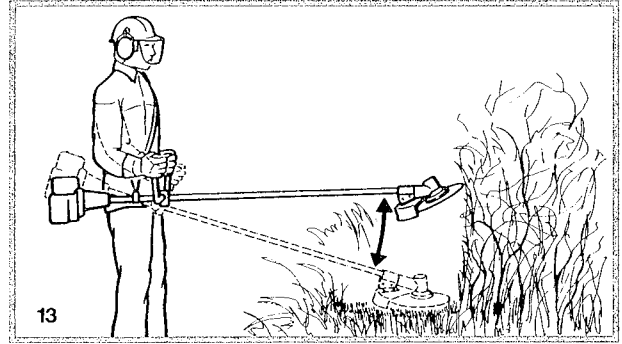

The blade has to be resharpened when all eight cutting edges are dull.

Using the brush knife

When fitted to the brushcutter, the brush knife is suitable for applications ranging from cutting matted grass to clearing weeds, wild growth and scrub.

To cut wild growth and scrub, lower the rotating brush knife down onto the growth to achieve a chopping effect (ill. 13). Use the brushcutter like a scythe to cut grass, i.e. sweep it to and fro in an arc.

Warning!

When cutting woody materials, use the left side of the blade to avoid "kickout" situations.

**Using the circular saw blade
(On brushcutters with handlebar only)**

Circular saw blades are suitable for thinning brush and cutting small trees up to a diameter of 7 cm (2¾ in). Do not attempt to cut trees with larger diameters, since the blade may catch or jerk the brushcutter forward. This may cause damage to the blade or loss of control of the brushcutter which may result in serious injury.

When the brushcutter with circular saw blade is used to cut down small trees, STIHL recommends that the standard deflector be removed and replaced by the special "stop" (see chapter "circular saw blade" for mounting instructions). This stop helps to keep the brushcutter positioned against the tree during the cutting process. Inexperienced users should place the left side of the stop against the tree trunk before beginning to cut. This act will keep the brushcutter against the tree during the cutting operation and will reduce the risk of loss of control and possible kickout (described in the following section).

Warning!

In order to reduce the risk of injury from thrown objects or from operator contact with the cutting tool, be sure to remount the standard deflector for all other uses.

Before starting the cut, accelerate the engine up to full throttle. Perform cut with uniform pressure. STIHL recommends that the circular saw blade be applied to the right of the tree, using the non-shaded area of the blade between 8 and 11 for cutting (see ill. 14).

Warning!

The risk of kickout is highest when cutting in the darker shaded area between 12 and 2 (ill. 14). To reduce the risk of kickout and resulting injury, do not use this area of the

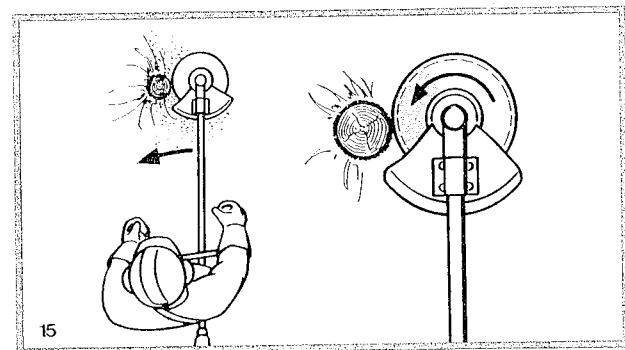
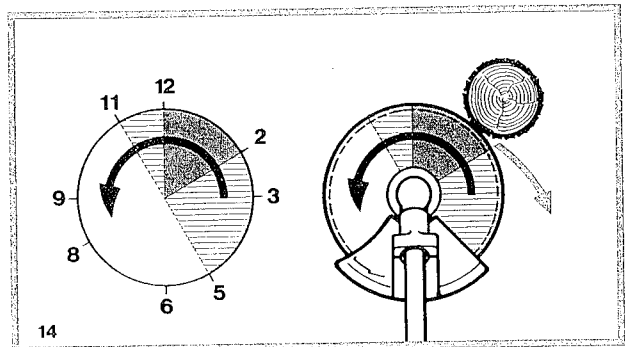

circular saw blade for cutting trees or shrubs. Special techniques using the lighter shaded areas of the blade from 11 to 12 and 2 to 5 (ill. 14) to cut shrubs and trees should only be used by experienced operators with specialized training in use and control of the brushcutter.

To reduce the risk of serious injury to operator or bystander by a kickout, never use a circular saw blade on a brushcutter with a loop handle.

Risk of “kickout” with all rigid cutting blades

Warning!

Kickout is the sudden and uncontrolled motion towards the operator’s right or rear that can occur when the shaded area of the rotating blade (ill. 14) comes in contact with a solid object like a tree, rock, bush or wall. The rapid counterclockwise rotation of the blade may be stopped or slowed, and the cutting attachment may be thrown in an area to the right or to the rear. This kickout may cause loss of control of the brushcutter and may result in serious or fatal injury to the operator or bystander. To reduce the risks, extreme caution should be used when cutting with the shaded area of any rigid blade.

MAINTENANCE, REPAIR AND STORING

Use only STIHL replacement parts for maintenance and repair. Use of parts manufactured by others may cause serious or fatal injury.

Follow the maintenance and repair instructions in the appropriate section of your owner’s manual.

Warning!

Always stop the engine and make sure that the cutting tool is stopped before doing any maintenance or repair work or cleaning the brushcutter. Do not attempt any maintenance or repair work not described in your owner’s manual. Have such work performed at your STIHL service shop only.

Never repair damaged cutting attachments by welding, straightening or modifying the shape. This may cause parts of the cutting tool to come off and result in serious or fatal injuries.

Check condition of cutting tool at regular short intervals. If behavior of tool changes, check it immediately for tightness or any signs of cracks in particular. Replace damaged or dull cutting tools immediately, even if they have only superficial cracks. If the blade loosens after being properly tightened, the retaining nut may be worn or damaged and should be replaced. Never use unauthorized parts to secure the blade. If the blade continues to loosen, see your STIHL dealer.

Check fuel filler cap for leaks at regular intervals. Use the specified spark plug and make sure it and the ignition lead are always in good condition.

Warning!

A worn or damaged muffler is a fire hazard and may cause loss of hearing. Check to see that the muffler is in good condition. The brushcutter must not be operated if the muffler is faulty or has been removed. Remember that the risk of forest fires is greater in hot weather. Use the firesafe muffler supplied with the unit. Never touch a hot muffler or burn will result.

Keep cutting tool sharp. Tighten all nuts, bolts and screws except the carburetor adjustment screws after each use.

Keep spark plug and wire connection tight and clean. The spark plug electrode gap should be checked with a feeler gauge at least every 50 operating hours and reset if necessary. Fit a new spark plug if the electrodes are badly pitted.

Store brushcutter in a dry place and away from children.

Before storing for longer than a few days always empty the fuel tank.

Assembling the Brushcutter

The brushcutter is partly disassembled for ease of shipment and must be assembled before it can be used for the first time.

It should be noted that there are differences between the FS 66 with two-handed handlebar and the FS 66 R with loop handle.

Warning! Because of the increased risk of accidents the powerhead must not be started while it is detached from the shaft.

Mounting the powerhead (All versions)

Take off the rubber cap and then push the drive tube into the slotted seat on the powerhead. The square head of the drive shaft (1) must engage the recessed square of the clutch drum (2).

Line up the drive tube so that the support on the engine and the curved end of the drive tube both in the same direction.

Screw in the fixing screw (3) – it engages in a hole in the drive tube – and then tighten down the clamp screw (4).

Top: Inserting drive tube
Center: Fixing screw (3) and clamp screw (4)
Bottom: Powerhead fitted

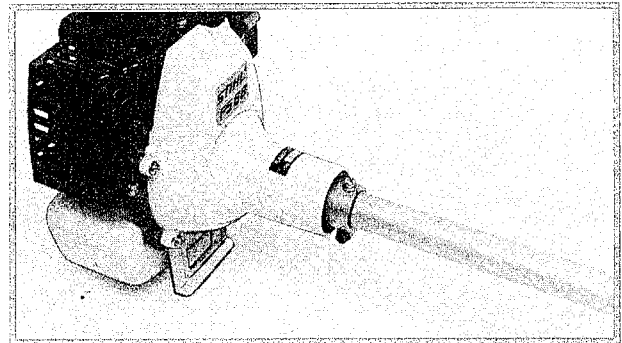
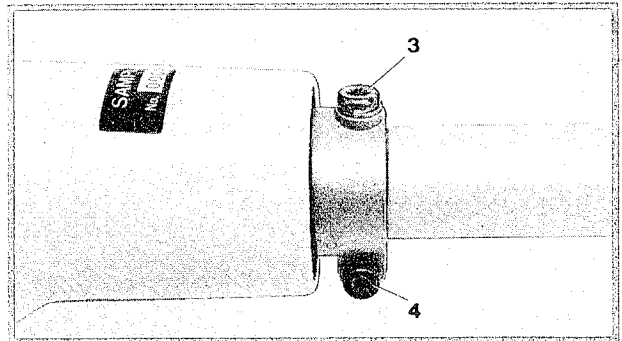
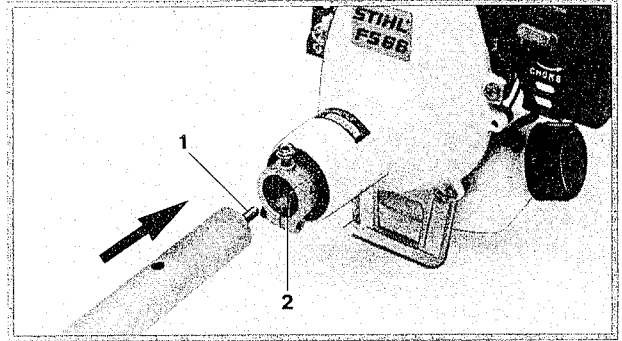

Top: Mounting two-handed handlebar
Bottom: Mounting loop handle

Mounting the two-handed handlebar (FS 66)

The two-handed handlebar should be mounted about 40 cm (16") forward of the hose clamp (5) on the drive shaft.

First slide the packing sleeve (6) along the drive shaft to the correct position for the two-handed handlebar (7).

Remove the mounting screws from the clamp (8) and take it off. Place handlebar support and handlebar (7) on the drive shaft so that the control handle is on the right (viewed from powerhead). Refit the clamp and tighten down the mounting screws.

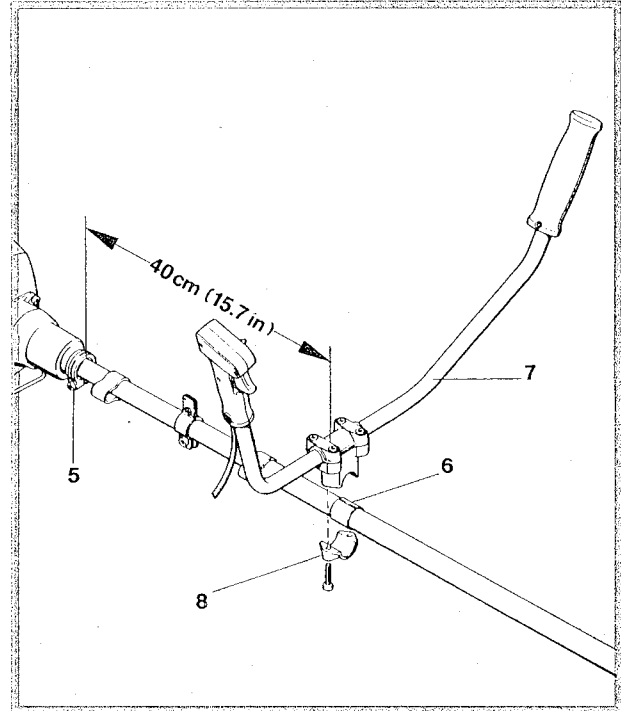

Mounting the loop handle (FS 66 R)

The loop handle should be fitted about 20 cm (8 in) forward of the control grip on the drive tube.

To do this, slide the sleeve (11) along the drive tube to the position where the loop handle (9) is to be fitted. Then use one of the two clamps (10) to attach the loop handle (9) to the sleeve. Now fit the second clamp (12) on the other side and insert the mounting screw (13) as well as the tommy screw (14) with washer.

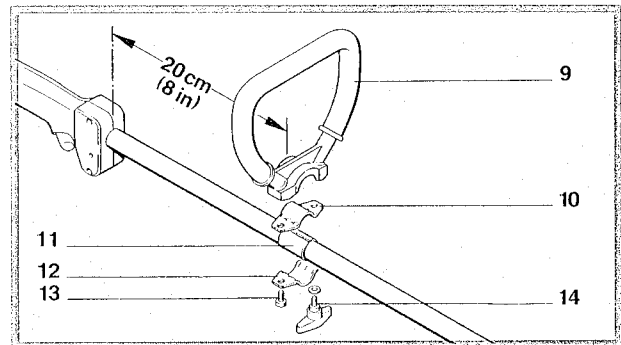

Finish off by lining up the loop handle and firmly tightening the mounting screws.

Top: Assembly sequence for polymer deflector
Center: Assembly sequence for metal deflector
Bottom: Correctly routed throttle cable on FS 66

Mounting the deflector (All versions)

Note: Approval and licensing regulations differ from country to country. Your brushcutter comes with only one of the deflectors illustrated.

To mount the deflector, lay the brushcutter on its back with the gear head facing upward.

Position the deflector (15), inside pointing up, on the gear. Now fit the plate (16) on the inside of the deflector and line it up. Insert the four screws and tighten them down securely.

The **accessories supplied** with the deflector need only be fitted when certain cutting tools are used. Refer to chapter “**Mounting the Cutting Tools**”.

Fitting the throttle cable (All versions)

Important: The throttle cable must never be kinked nor bent in tight radius.

The throttle cable, with integrated stop switch lead, is already connected at the control grip.

Take the two hexagon nuts (10 mm wrench) off the throttle cable's screw sleeve.

FS 66

Push the throttle cable/stop switch lead through the two retainers (17) on the drive shaft and through the hole in the support (18).

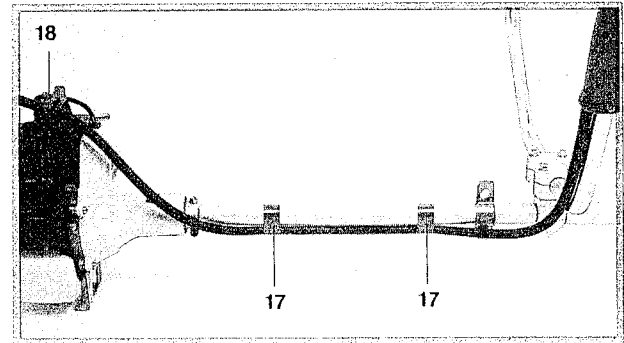
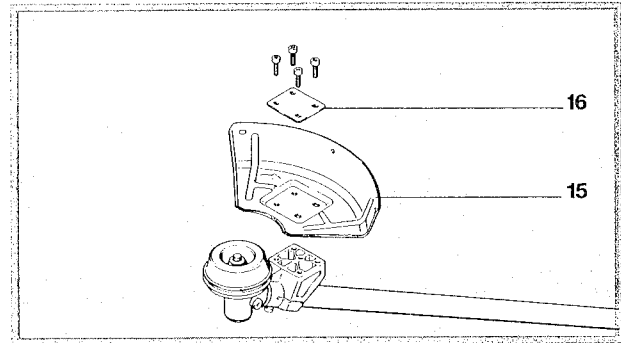
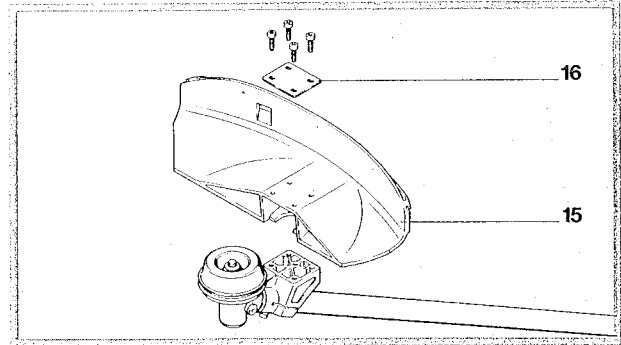

Fitting throttle cable in retainer

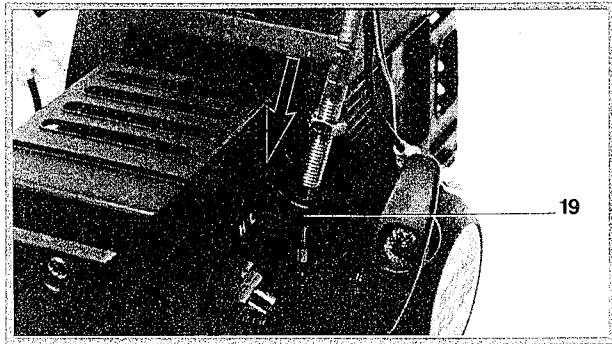

FS 66 R

Thread the throttle cable/stop switch lead through the hole in the support (18).

All versions

Refit one of the hexagon nuts on the throttle cable's screw sleeve. Insert screw sleeve in the retainer (19) and then fit the other hexagon nut.

Now engage the end of the throttle cable in the slotted pin (20) on the carburetor's throttle lever so that the nipple slides into the bore in the slotted pin.

Top: Attaching cable nipple to throttle lever
Center: Throttle cable in position
Bottom: Throttle lever butts against idle adjusting screw

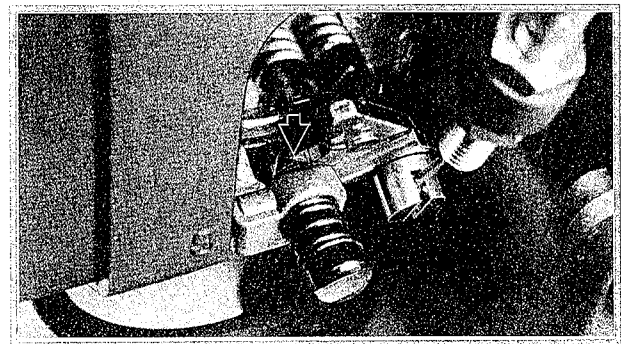
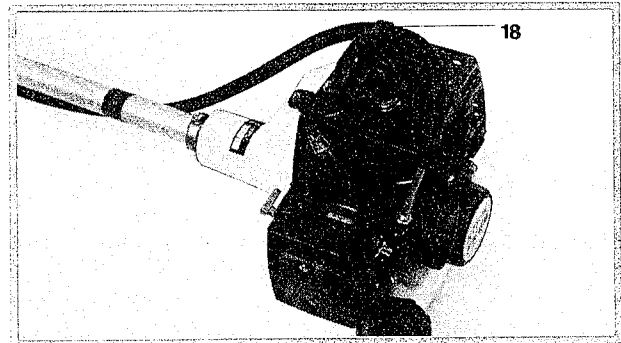
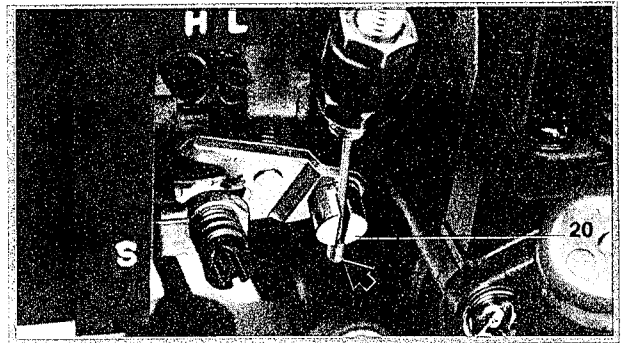

Top: Throttle lever butts against carburetor body
Center: Securing hexagon nuts
Bottom: Stop switch lead connected at engine end
(filter cover removed)

Adjusting the Throttle Cable (All versions)

The two hexagon nuts are used for final adjustment of the throttle cable. Adjust length of throttle cable by turning nuts until the carburetor's throttle lever butts against the idle speed adjusting screw when the throttle trigger is in the idle position and against the stop on the carburetor body when the throttle trigger is in the full throttle position.

Tighten down the hexagon nuts securely (10 mm wrench) after completing the adjustment.

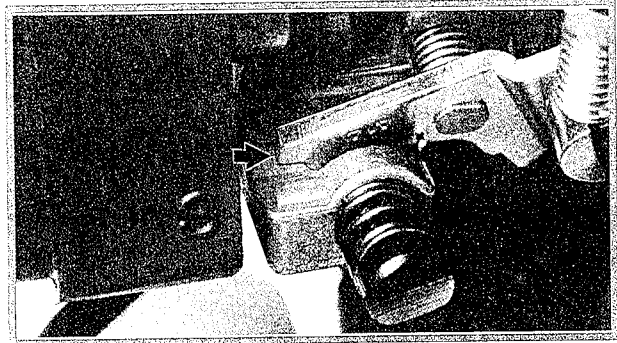

Connecting the Stop Switch Lead (All versions)

The stop switch lead is already connected at the control grip. At the engine end it is necessary to plug the round terminal (22) into the spare hole on the double socket (21) and attach the spade terminal (23) to the ground tag (24).

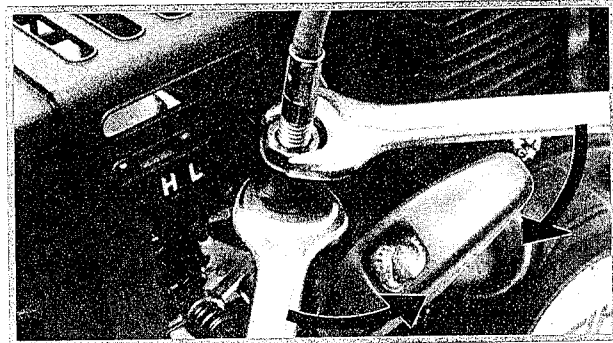

Important: The plug connections of the stop switch lead must be secure and in good condition to ensure proper operation of the stop switch.

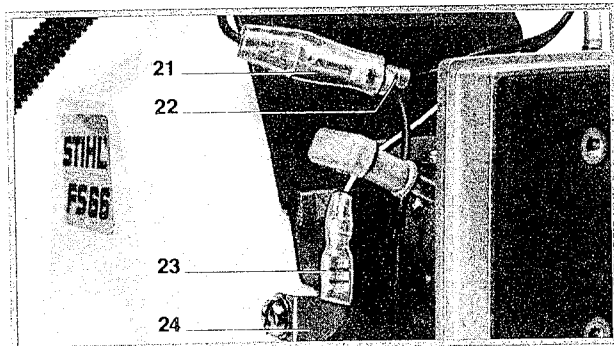

Mounting the Cutting Tools

Lay the brushcutter on its back, gear head facing upward, to mount or change the cutting tool.

Insert the Allen key, included in tool kit, in the bore at the side of the gear head. Turn the mounting nut until the pin slips into position. This blocks the drive shaft to prevent it rotating while you are releasing or tightening the mounting nut.

Use combination wrench to release and remove the mounting nut clockwise (left-hand thread). Take off the thrust washer.

The cutting tool can now be mounted and secured in position.

The **following cutting tools** are approved for use with the **FS 66**. Note that one or other of the cutting tools may not be available on some markets.

- 1 STIHL "Supercut 2" mowing head
- 2 STIHL "Polycut 1" mowing head
- 3 STIHL "Polycut 2" mowing head
- 4 STIHL "Polymatic 2" mowing head
- 5 Grass cutting blade 230
- 6 Brush knife 250
- 7 Circular saw blade 200 (scratcher tooth)
- 8 Circular saw blade 200 (chisel tooth)

Important:

Only the following cutting tools are authorized for the FS 66 R brushcutter (version with loop handle). Note that one or other of the cutting tools may not be available on some markets.

- 1 STIHL "Supercut 2" mowing head
- 2 STIHL "Polycut 1" mowing head
- 3 STIHL "Polycut 2" mowing head
- 4 STIHL "Polymatic 2" mowing head
- 5 Grass cutting blade 230
- 6 Brush knife 250

Top: Blocking the drive shaft
Center: Releasing the mounting nut
Bottom: STIHL cutting tools

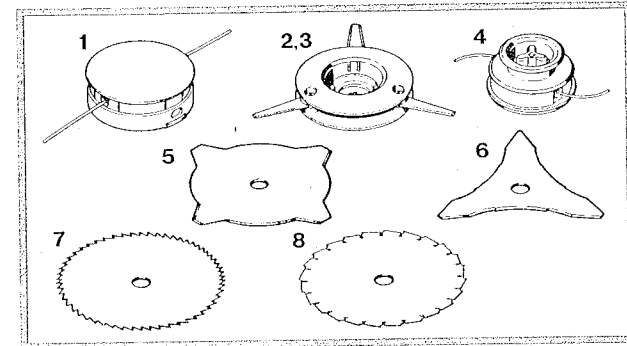
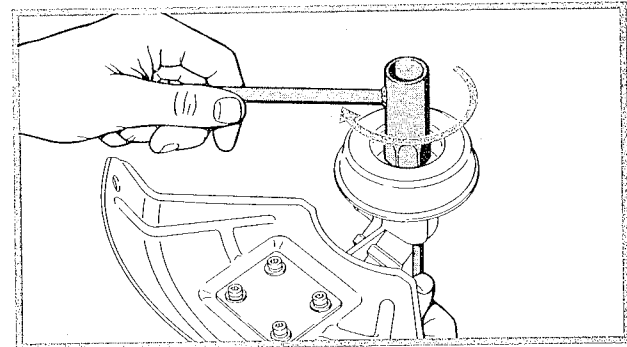
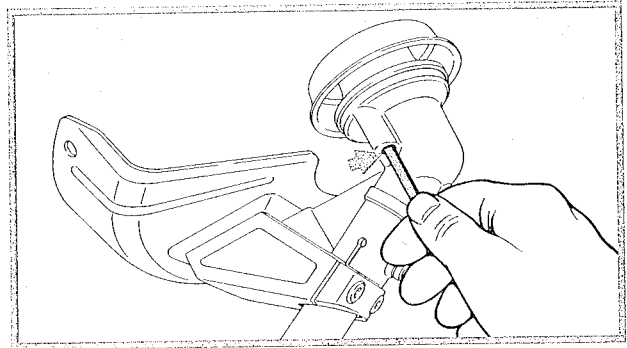

STIHL "Supercut 2" Mowing Head

Important: The "Supercut" may only be used in conjunction with the polymer deflector (1) and blade (3).

Before fitting the mowing head, slide the skirt (2) onto the deflector (1) in direction of arrow (see illustration). It must snap into position.

Note: Push blade (3) into skirt's (2) guide in direction of arrow and slide it along until it lines up with the first hole. Fit and firmly tighten down the screw (4).

The skirt and blade must be removed in the **direction opposite the arrow** before using any other kind of cutting tool.

Now screw mowing head counterclockwise onto the shaft (5) (left-hand thread) as far as it will go.

It is not necessary to tighten the mowing head any further since its left-hand thread causes it to tighten up automatically during operation.

To remove the mowing head, block the drive shaft by inserting the stop pin through the bore in the gear head and then release and unscrew the mowing head clockwise.

Top: Deflector, skirt and blade; guide slot for Supercut 2
Center: Mounting STIHL "Supercut 2"
Bottom: STIHL "Supercut 2" fitted in position

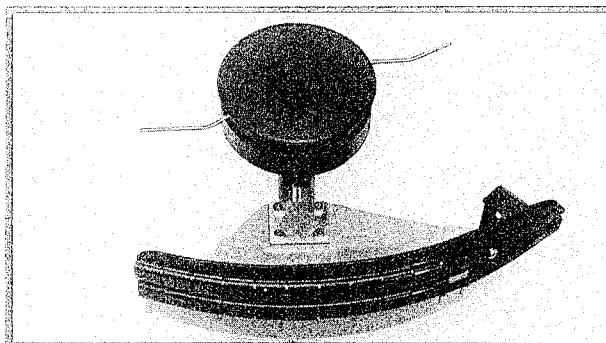
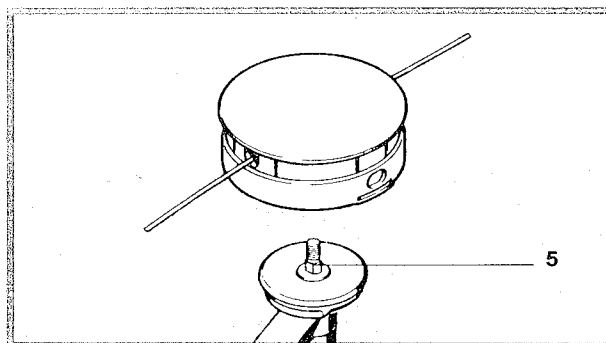
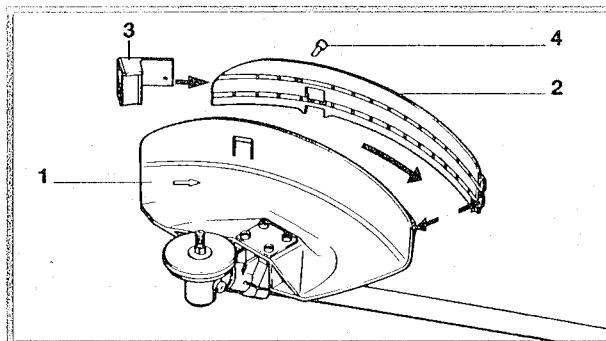

STIHL "Polycut 1" Mowing Head*

Metal deflector (2):

Before fitting the mowing head attach the extension (1) to the metal deflector (2) with the screws and washers provided.

Polymer deflector (4):

Before fitting the mowing head slide the skirt (3) onto the polymer deflector (4).

The extension or skirt must be removed before using any other kind of cutting tool.

There is a **metal ring in the center of the mowing head**. This ring is not required for models FS 66 and should be removed with a screwdriver before you mount the mowing head.

Now place the flat side of the mowing head on the thrust plate (8). Slip the thrust washer (6) over the shaft (7) – the shoulder on the thrust washer must face away from the gear head.

Screw mounting nut (5) onto the shaft (7) (left-hand thread). Block the drive shaft by inserting the stop pin through the bore in the gear head and then use combination wrench to tighten down the mounting nut securely.

* Recommended in the USA only.

Top: Metal deflector with extension and mounting hardware
Center: Polymer deflector with skirt; guide slot for Polycut 1
Bottom: Correct assembly sequence

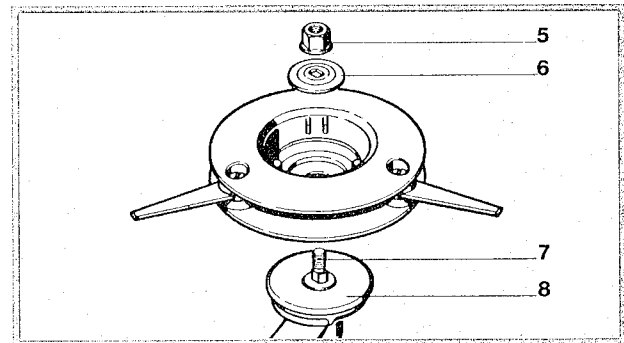
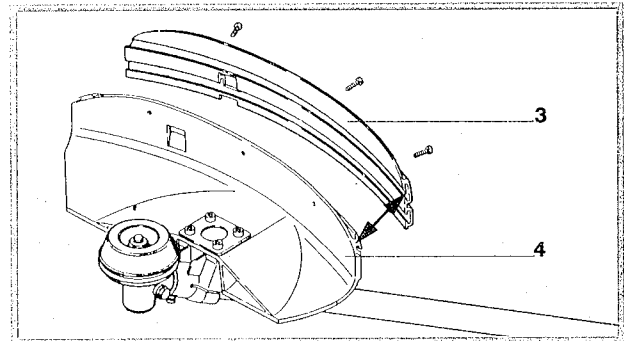
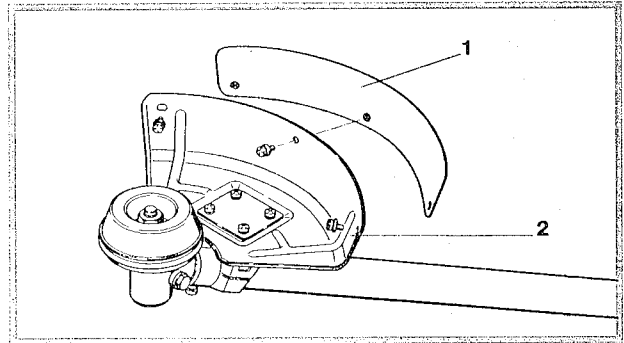

STIHL "Polycut 2" Mowing Head*

Metal deflector (2):

Before fitting the mowing head attach the extension (1) to the metal deflector (2) with the screws and washers provided.

Polymer deflector (5):

Before fitting the mowing head slide the skirt (4) onto the polymer deflector (5).

The extension or skirt must be removed before using any other kind of cutting tool.

To reduce the risk of injury from thrown objects, keep the skirt on the deflector adjusted properly at all times.

Fit the mowing head by screwing its inside thread counter-clockwise (left-hand thread) onto the thread of the drive shaft (6) as far as the stop.

It is not necessary to tighten the mowing head any further since its left-hand thread causes it to tighten up automatically during operation.

To remove the mowing head, block the shaft by inserting the pin in the bore at the side of the gear head. Then release and unscrew the mowing head clockwise.

Top: Metal deflector with extension and mounting hardware
Center: Polymer deflector with skirt; guide slot for Polycut 2
Bottom: Correct assembly sequence

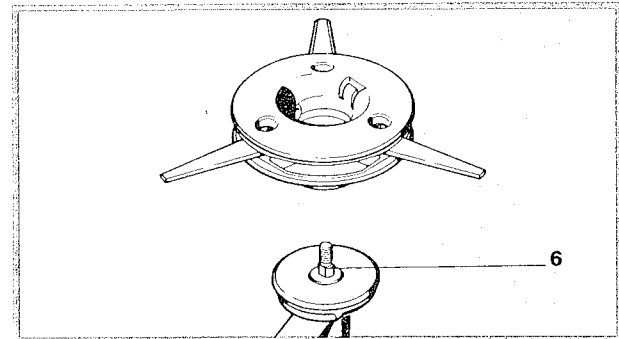
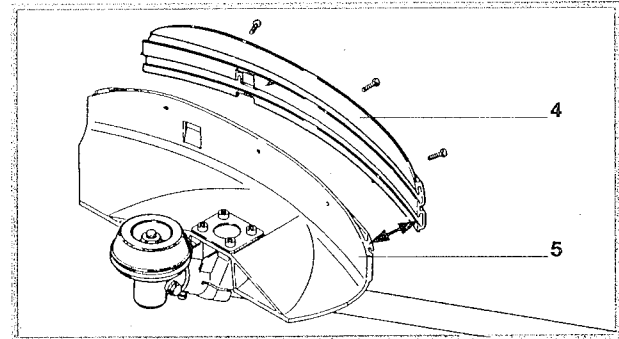
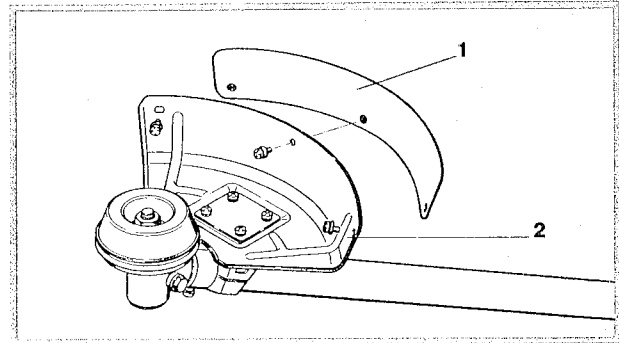

STIHL "Polymatic 2" Mowing Head

Metal deflector (2):

Before fitting the mowing head attach the extension (1) to the metal deflector (2) with the screws and washers provided.

Polymer deflector (5):

Before fitting the mowing head slide the skirt (4) onto the polymer deflector (5).

The extension or skirt must be removed before using any other kind of cutting tool.

To reduce the risk of injury from thrown objects, keep the skirt on the deflector adjusted properly at all times.

A number of accessories are supplied with the mowing head. Only the washer (7) is required. It is fitted on the guard washer (9).

Slip the thrust washer (6) over the shaft (8) so that its shoulder faces upward.

Now secure the mowing head by screwing its female thread counter-clockwise (left-hand thread) onto the drive shaft (8) as far as the stop.

It is not necessary to tighten the mowing head any further since it tightens up automatically during operation.

To remove the mowing head, block the drive shaft by inserting the pin through the bore in the gear head and then release and unscrew the head in the clockwise direction.

Top: Metal deflector with skirt, extension and mounting hardware
Center: Polymer deflector with skirt; guide slot for Polymatic 2
Bottom: Correct assembly sequence

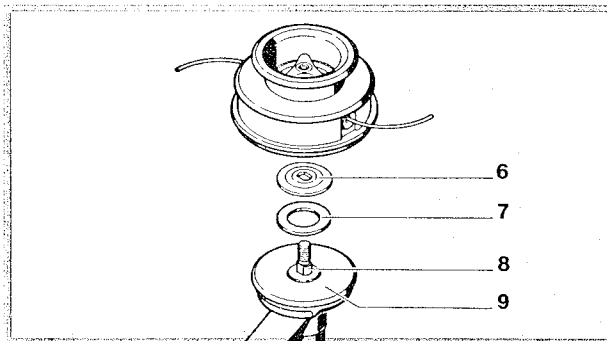
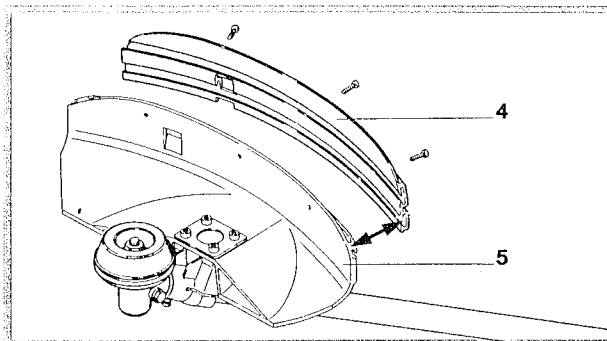
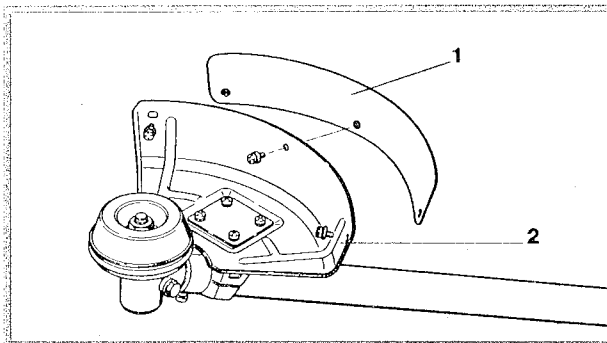

Grass Cutting Blade 230 Brush Knife 250

Top: Grass cutting blade 230 in position (e.g. metal deflector)
Bottom: Brush knife 250 in position (e.g. polymer deflector)

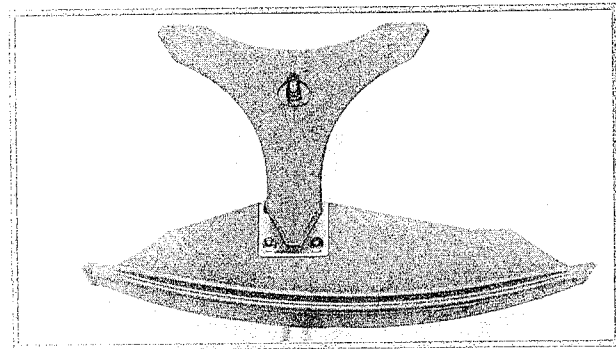
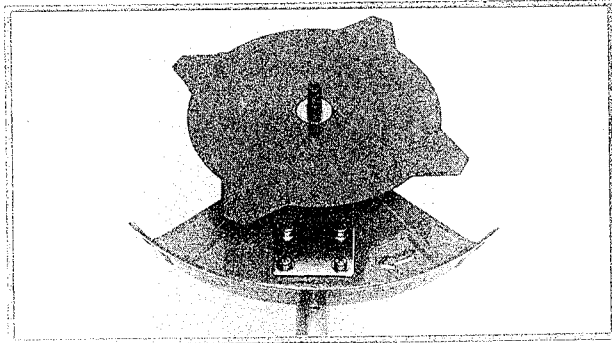

The steel cutting tools, i.e. grass cutting blade 230 and brush knife 250, are secured in the same way – irrespective of whether they are supplied with a metal (1) or polymer (2) deflector.

Place the tool on the guard washer (8). The tool is centered by the raised collar of the thrust plate (7).

26 These two cutting tools may be fitted either way round.

Correct assembly sequence

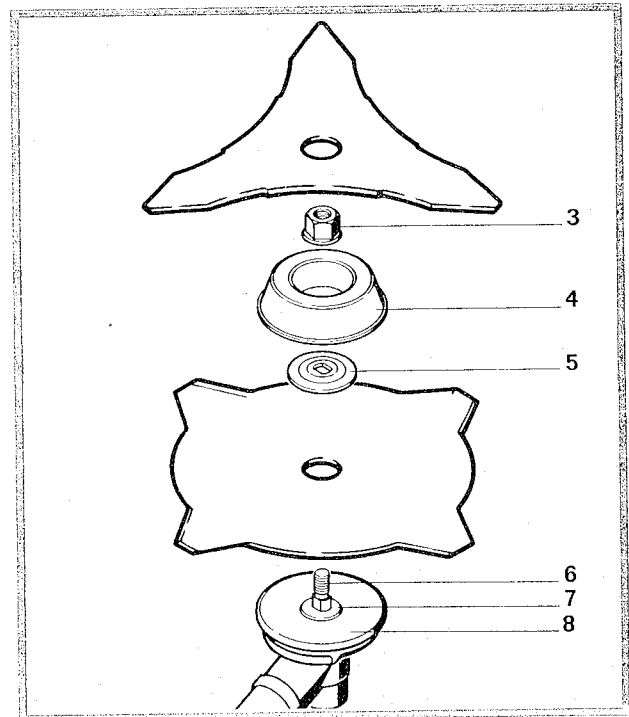

Now fit the thrust washer (5) over the shaft (6) so that its shoulder faces upward. After fitting the rider plate (4) on the thrust washer (5), screw the mounting nut securely (3) counter-clockwise (left-hand thread) onto the shaft.

Block the drive shaft by inserting the stop pin through the bore in the gear head and then use combination wrench to tighten down the mounting nut securely.

Circular Saw Blade 200 (Scratcher and Chisel Tooth)

For cutting down small trees STIHL recommends to assemble the stop supplied in the mounting kit. To do this, remove the standard deflector (4 screws) and fit the stop (1) on the clamp (2) with the screws provided in the kit. The deflector should be remounted when the circular saw blade is employed for other use or when other types of cutting tools are mounted.

Note when fitting the circular saw blade on the guard washer (8) that the cutting edges must point in the clockwise direction. The blade is centered by the raised collar of the thrust plate (7).

Now fit the thrust washer (5) over the shaft (6) so that its shoulder faces upward. After fitting the rider plate (4) on the thrust washer (5), screw the mounting nut (3) counterclockwise (left-hand thread) onto the shaft.

Block the drive shaft by inserting the stop pin through the bore in the gear head and then use combination wrench to tighten down the mounting nut securely.

Top: Mounting points for stop
Bottom: Correct assembly sequence

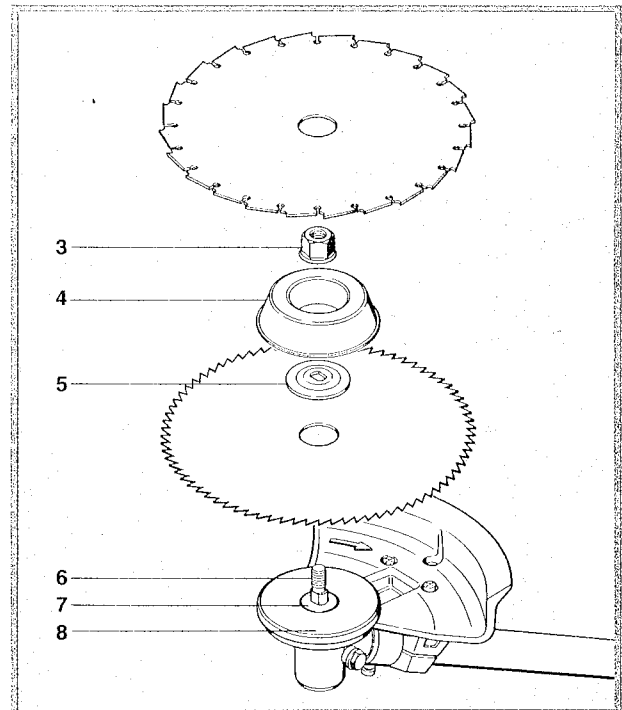
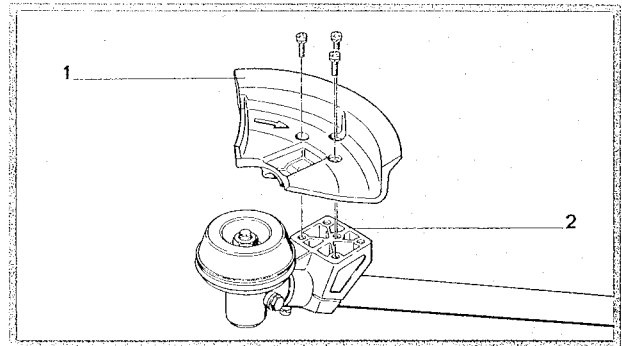

Fuel

Fuel filler cap removed

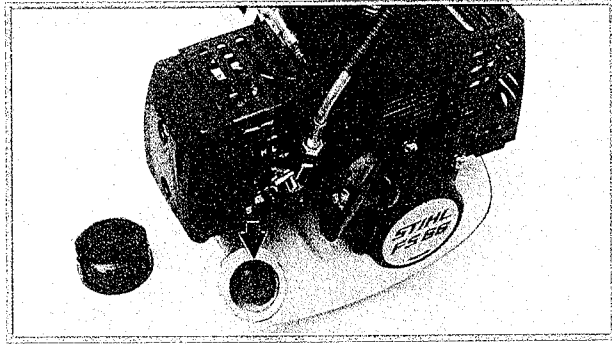

Your two-stroke engine runs on a mixture of gasoline and two-stroke, air-cooled engine oil.

Use regular branded gasoline, leaded or unleaded, with a minimum octane number of 90 RON (U.S.A.: pump octane min. 87!). If the octane number of the regular grade gasoline in your area is lower, it may cause preignition (“pinging”) which is accompanied by a rise in engine temperature. This increases the risk of piston seizure and damage to the engine.

The chemical composition of the fuel is also important. Some fuel constituents not only detrimentally affect elastomers (carburetor diaphragms, oil seals, fuel lines etc.), but magnesium castings as well. This could cause running problems or even damage the fuel tank. For this reason it is essential that you use only name branded fuels!

Use only STIHL two-stroke engine oil or equivalent branded two-stroke air-cooled engine oils for mixing. We recommend STIHL 40:1 two-stroke engine oil since it is specially formulated for use in STIHL engines. The mix ratio with STIHL oil is 40:1 (40 parts gasoline to 1 part oil), or 25:1 (25 parts gasoline to 1 part oil) with other branded two-stroke air-cooled engine oils.

Do not use BIA or TCW (two-stroke water cooled) mix oils!

Lit.	Gasoline		STIHL-engine oil 40:1 mix		Other branded two-stroke engine oils 25:1	
	U.S.- Gallons	Liters	U.S.- Ounces	Liters	U.S.- Ounces	
1.0	—	0.025	—	0.04	—	
—	1.0	—	3.2	—	5.12	
5.0	—	0.125	—	0.20	—	
—	2.5	—	8.0	—	2.8	
10	—	0.250	—	0.40	—	
—	5.0	—	16.0	—	25.6	

Take care when handling gasoline. Avoid direct contact with the skin and avoid inhaling fuel vapour.

When mixing, pour oil into the canister first, and then add gasoline. The canister should be kept tightly closed in order to avoid any moisture getting into the mixture. The fuel mixture must not be stored for long periods of time. Do not store large quantities. Always mix sufficient fuel for about a few month’s work or the project in hand.

Always thoroughly shake the mixture in the canister before fueling your machine. The fuel tank may be under pressure. Remove cap slowly!

The fuel tank and the canister in which fuel mix is stored should be cleaned from time to time.

Change the filter element in the fuel pick up body every year.

Fitting the Harness – balancing the Brushcutter

Harness fitted



The harness supplied with the brushcutter must be worn over the left shoulder so that the spring hook hangs at the right hip after its length has been suitably adjusted.

The brushcutter must be properly balanced after you attach the spring hook to the carrying ring on the drive tube. This is done by slackening the screw with the combination wrench on the clamp and moving the carrying ring along the drive tube.

If you use a mowing head (STIHL “Polycut 2 or 1”, STIHL “Polymatic 2”), grass cutting blade or brush knife, balance the brushcutter so that the mowing head or rider plate rests on the ground when you let go of the handles.

In the case of the circular saw blade, balance the brushcutter so that the blade stays about 30 cm (1 ft) above the ground when you let go of the handles.

Top: Adjusting carrying ring
Center: Balanced with ground contact
Bottom: Balanced about 30 cm (1 ft) from ground

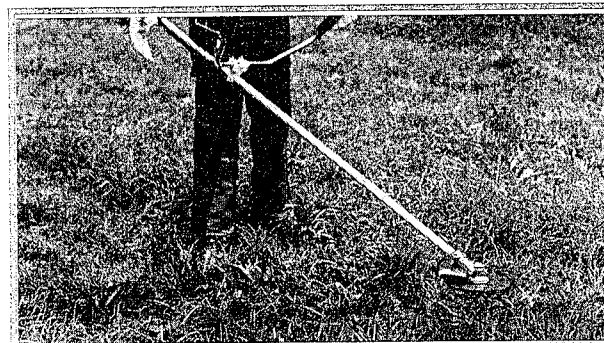
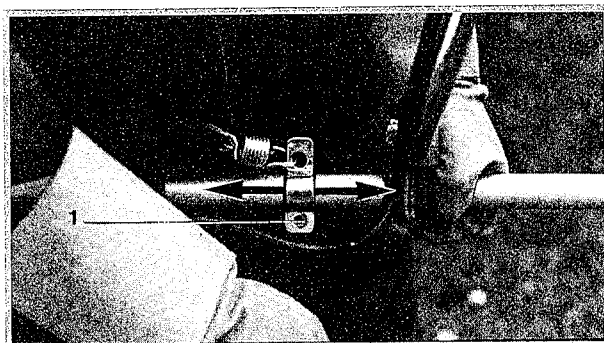

Notes on Operation

Starting for first time

A factory new machine should be run with the carburetor set slightly on the rich side for the first three tank fillings (see chapter on "Carburetor") so that the cylinder bore and the bearings receive additional lubrication during the break-in period.

As all the moving parts have to bed in during the break-in period, the frictional resistances in the engine are greater during this period. For this reason the engine only develops its maximum power after about 5 to 15 tank fillings. The carburetor setting must never be made leaner in order to achieve an apparent increase in power as this could cause the engine to exceed its maximum permissible rpm (see "Specifications" and "Carburetor").

During operation

After a long period of working at full load it is advisable not to shut off the engine immediately, but let run for a short while at idling speed. This allows the heat which has been generated in the engine during full throttle operation to be dissipated by the flow of cooling air and also protects engine-mounted components (ignition, carburetor) from thermal overload.

Spark plug

An incorrect carburetor setting, the wrong fuel mix (too much engine oil in the gasoline), a dirty air filter and unfavorable running conditions (mostly at part throttle etc.) affect the condition of the spark plug. These factors cause deposits to form on the insulator nose which may result in trouble in operation.

Top: Spark plug in good condition
Bottom: Spark plug fouled because of incorrect running conditions

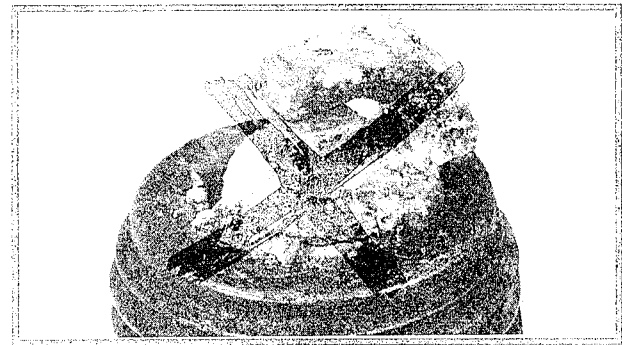
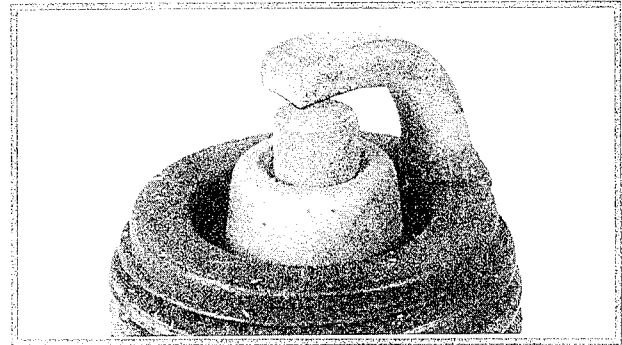

If the engine is down on power, difficult to start or runs poorly at idling speed, check the spark plug before looking any further. If the spark plug is dirty, clean it and check the electrode gap. Readjust if necessary; the correct gap is 0.5 mm (0.02 in). The spark plug should be replaced after about 100 operating hours or earlier if the electrodes are badly eroded.

In order to ensure trouble-free operation it is necessary to rectify the faults which have caused fouling of the spark plug.

Starting

Although the position of the control grip differs on the FS 66 and FS 66 R brushcutters, it is operated in the same way in both cases. The following description of the starting procedure therefore applies to both versions.

To start, place the brushcutter on a clear patch of ground so that it rests on the wire bracket and the tool guard. Make sure you have a firm foothold, keep a firm grip on the machine and check that the cutting tool is clear of the ground and any other obstructions.

Starting Procedure

1. Squeeze the throttle trigger (2) and move the slide control (1) on the control grip to "START". Release the throttle trigger – it will now remain in the start position.
2. Always start a **cold engine** with the choke closed. Move the choke lever (3) to "CHOKE".

Start a **warm engine**, or one that has only been stopped for a short period, with the choke open. Move choke lever (3) away from "CHOKE".

Top: Slide control on "START", throttle trigger in start position
Center: Choke lever in closed position
Bottom: Choke lever in open position

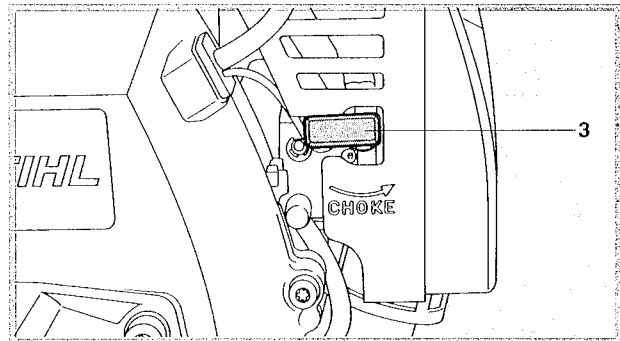
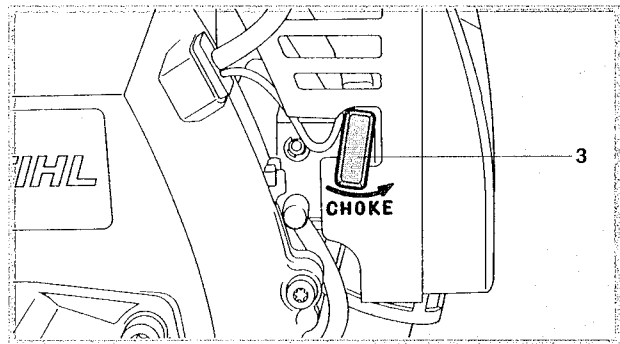
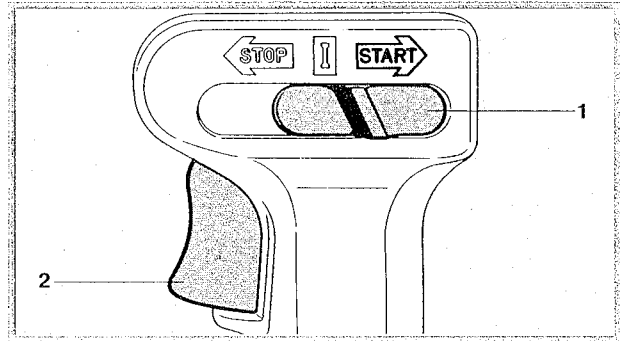

3. To start, hold the machine with your left hand on the drive tube (FS 66) or control grip (FS 66 R). Pull the starter grip slowly with your right hand until you feel it engage and then give a brisk strong pull. Do not pull the starter rope out more than about 70 cm (27") as it might otherwise break.

Do not allow the starter rope to snap back. Guide it slowly back into the housing so that it can rewind correctly.

Continue cranking the engine until it begins to fire. Then open the choke immediately (move choke lever away from "CHOKE") and continue cranking.

4. Once the engine is running, blip the throttle trigger (2) to release the slide control (1) (the slide control moves to center position "I") so that the engine can settle down to idle speed.

5. To stop the engine, push the slide control (1) to "STOP".

Top: Starting
Center: Throttle trigger in idle position, slide control in position "I"
Bottom: Slide control on "STOP"

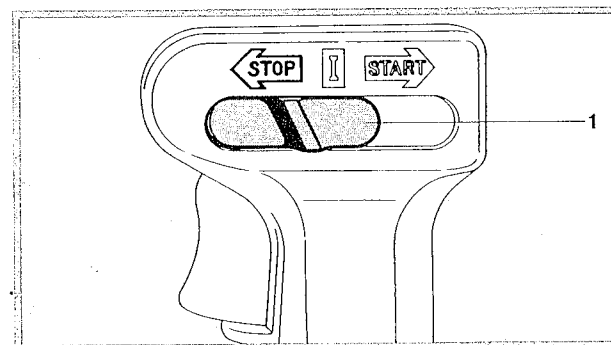
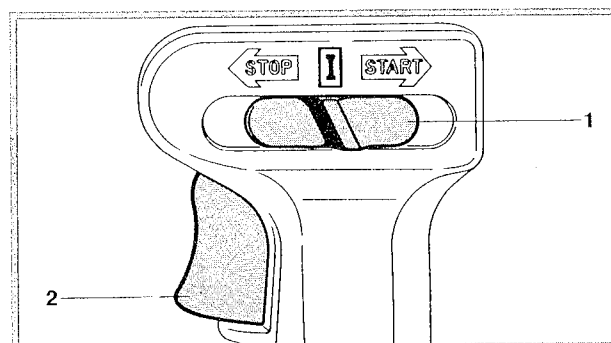
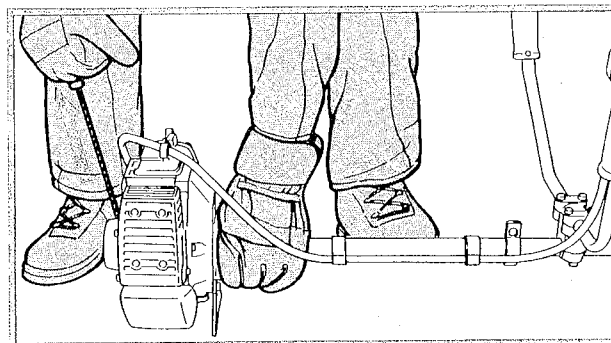

Other points to observe when starting the engine:

When starting a cold engine only keep the choke closed until the engine begins to fire. Then open the choke fully even if the engine stops and you have to continue cranking. If the choke is left closed, the combustion chamber will flood and stall the engine.

At very low outside temperatures the choke should only be opened half way (move choke lever to center position) and the engine allowed to warm up for a brief period using a little throttle. Then let go of the throttle trigger and open the choke fully.

If you have opened the choke as soon as the engine began to fire and the engine still does not run after several attempts, it is already flooded. In such a case, remove and dry off the spark plug. with the spark plug still removed, set the slide control to "STOP", open the throttle fully and then crank the engine over several times with the starter rope to clear the combustion chamber.

A new engine or one which has been run until the fuel tank is dry will not start the first time after refueling because the carburetor's diaphragm pump has to be primed with fuel by cranking the engine over several times on the starter.

Carburetor

- 1 = High speed adjusting screw
- 2 = Low speed adjusting screw
- 3 = Idle speed adjusting screw

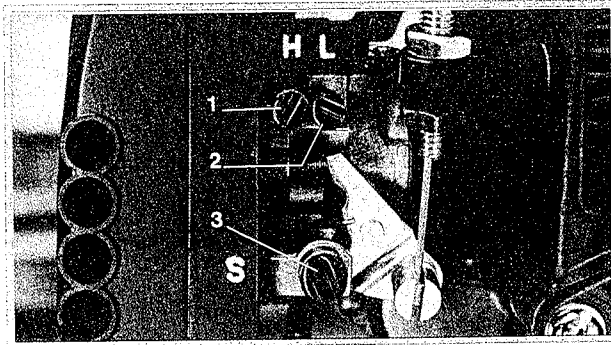

When the engine is tested at the factory the carburetor is set to obtain a slightly richer mixture to ensure that the cylinder bore and the bearings receive additional lubrication during the break-in period. This setting should be left as it is for the first three tank fillings. The high speed adjusting screw may then be turned no more than $\frac{1}{4}$ turn clockwise (leaner mixture). Caution: The engine's maximum permissible r.p.m. must not be exceeded!

If you use your Brushcutter at high altitudes (mountains) or at sea level it may be necessary to change the carburetor setting slightly. Carry out the correction at the two adjusting screws (1 and 2) as follows: Turn clockwise (leaner) for high altitude operation or counterclockwise (richer) for operation at sea level.

Note that even slight alterations on the adjusting screws have a noticeable effect on the engine's running behavior. Only carry out carburetor adjustments after cleaning the air filter and warming up the engine.

Caution: Adjustment of the high speed adjusting screw not only affects the power output but also the maximum off-load engine speed. If the setting is too lean (screw

turned too far clockwise), the maximum permissible engine speed will be exceeded. This can cause engine damage, brought about by lack of lubrication and overheating in particular. Corrections to the setting of the high speed adjusting screw may be carried out only if an accurate tachometer is available to check the maximum engine speed of 10,000 r.p.m. The adjustment should be performed either without a cutting tool or with the grass cutting blade 230, brush knife 250 or circular saw blade 200.

Basic setting

If it is necessary to readjust the carburetor again from the beginning, first carry out the basic setting to obtain a starting point for fine adjustment. To do this, carefully screw the two adjusting screws down onto their seats (clockwise). Then make the following adjustment:

High speed adjusting screw H: back off 1 complete turn
Low speed adjusting screw L: back off 1 complete turn

If you have no means of checking the maximum engine speed, do not set the high speed adjusting screw any leaner by turning it beyond the basic setting.

Notes for adjusting idle speed

Engine stops while idling

Turn idle speed adjusting screw (3) clockwise until cutting tool begins to rotate. Then back off one half turn. The cutting tool must not rotate.

Cutting tool rotates when engine is idling

Turn idle speed adjusting screw (3) counterclockwise until cutting tool stops rotating and then turn it another one half turn.

Erratic idling behavior; poor acceleration

Idle setting too lean; turn low speed adjusting screw (2) counterclockwise until engine runs and accelerates smoothly.

Exhaust smokes at idle speed

Idle speed setting too rich; turn low speed adjusting screw (2) clockwise until engine speed drops. Then turn screw back one quarter turn and check that engine still accelerates smoothly when you open the throttle.

A correction at the low speed adjusting screw usually necessitates a change in the setting of the idle speed adjusting screw (3).

Apart from minor readjustments, you should leave all carburetor setting and repair work to your STIHL dealer. STIHL dealers have trained staff and all the necessary servicing tools and equipment.

Air filter

Component parts in correct sequence

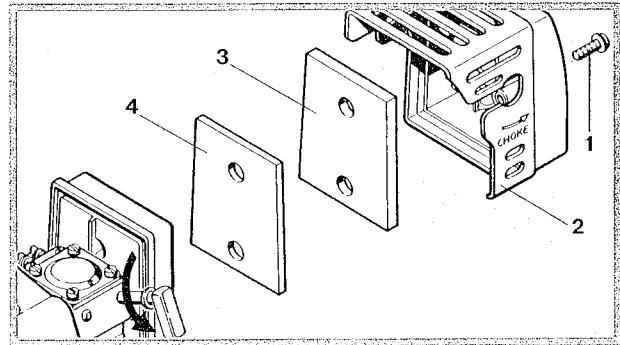

The purpose of an air filter is to prevent the dust and dirt in the intake air from entering the carburetor. It thus helps reduce wear on the engine components to a minimum.

Clogged air filters reduce engine power, increase fuel consumption and make starting more difficult.

The air filter must therefore be cleaned when engine power begins to drop off.

Before removing the filter, close the choke (choke lever to "CHOKE") to stop dirt getting into the carburetor. Remove the screw (1) and take off the filter cover (2), foam element (3) and felt element (4).

Wash foam filter element in fresh, non-flammable cleaning solution. Shake out or blow out felt filter element. Replace if heavily soiled.

Never refit a damaged filter element, always fit a new one.

Install air filter assembly in the reverse sequence. When fitting the filter cover, make sure that the intake openings point toward the starter mechanism.

Gearbox Lubrication

Tube of grease screwed into position

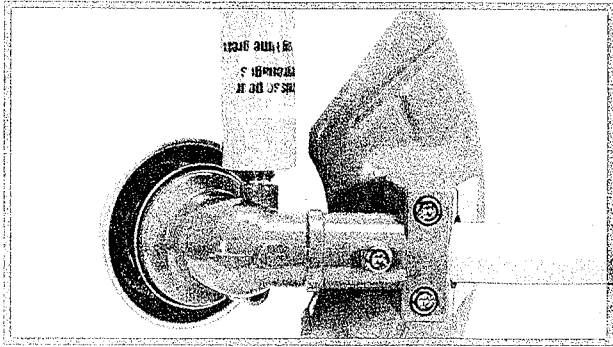

Use STIHL gear lubricant (0781 120 1117) for lubrication of the bevel gearing. It is a heavy-duty grease specially formulated for brushcutter gears.

The grease level should be checked at regular intervals (about every 50 hours of operation) and topped up as necessary.

To do this, release and remove the filler plug on the side of the gearhead. If no grease can be seen on the inside of the filler plug, screw the tube of STIHL gear lubricant into the filler hole and squeeze grease into the gear housing. Do not use more than 5–10 g (1/4 oz) grease at a time.

Important: The gear housing must not be completely filled with grease, i.e. heat during normal operation would cause excess grease to be forced out of the gear housing.

Refit the filler plug.

Sharpening the Grass Cutting Blade

- 1 Cutting edges
- 2 Cutter
- 3 Blade body

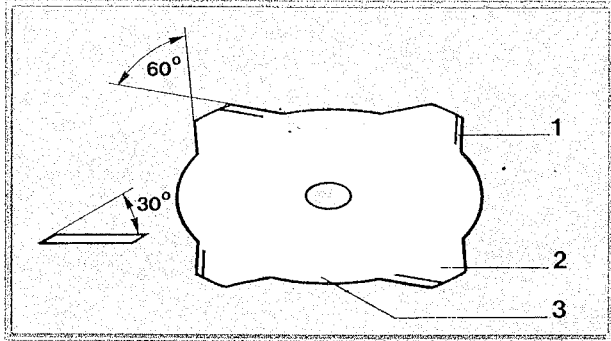

The cutting edges should not be sharpened until the blade has been turned and all eight cutting edges are dull. This is important in order to help avoid the cutting tool becoming warped.

Only the cutting edges on the cutters are sharpened. The contour of the blade body must not be altered in any way.

When the cutting edges are just slightly dull they can be resharpened with a few strokes of a flat file 0814 212 3310. However, in the case of more serious wear or nicked cutting edges a grinder may be used.

In any event a filing angle of 30° should be maintained on the cutting edges and an angle of 60° on the cutters (see illustration). In order to avoid out-of-balance it is necessary to ensure that all four cutters are exactly the same size.

Warning! For safety reasons a bent or cracked grass cutting blade must neither be straightened nor welded. It may shatter at high speed and cause serious or fatal injury.

Sharpening the Brush Knife

Filing a cutting edge

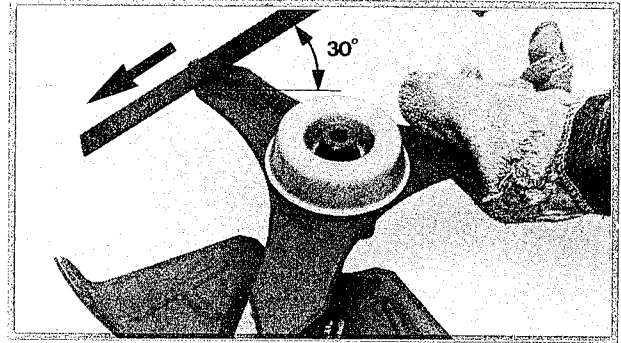

The brush knife can be sharpened either while it is still on the brushcutter or clamped in a vice.

Only sharpen the cutting edges at the pointed tips. It is not necessary to resharpen the curved cutting edges even if they are nicked in places.

A few strokes of a flat sharpening file (0814 212 3310) will be sufficient to restore the cutting edge if it is just slightly dull. If the cutting edges are blunt or chipped it will be necessary to file back all the tip cutting edges by the same amount. A grinder can also be used for this purpose. A symmetrical sharpening angle of 30° must always be maintained.

In order to avoid out-of-balance all the tips of the brush knife must have the same shape after sharpening. This can be checked with the sharpening template enclosed with the pack.

Warning! For safety reasons a bent or cracked brush knife must not be repaired! It may shatter at high speed and cause serious or fatal injury.

Sharpening the Circular Saw Blade (Scratcher and Chisel Tooth)

Filing tooth face on scratcher tooth saw blade

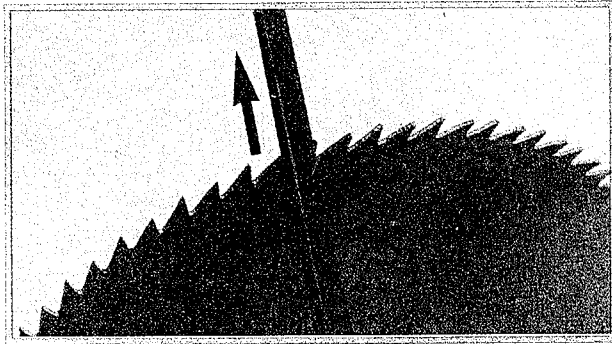

Scratcher tooth circular saw blade

Resharpener can be performed with triangular file 0811 421 8971 to remove minor blemishes or touch up normal dull teeth.

However, if the teeth show signs of more advanced wear or are chipped, the saw blade must be resharpened on an automatic grinding machine.

Your STIHL Service Shop will give you full details.

Top: Filing side plate of chisel tooth circular saw blade
Bottom: Filing angles on chisel tooth circular saw blade

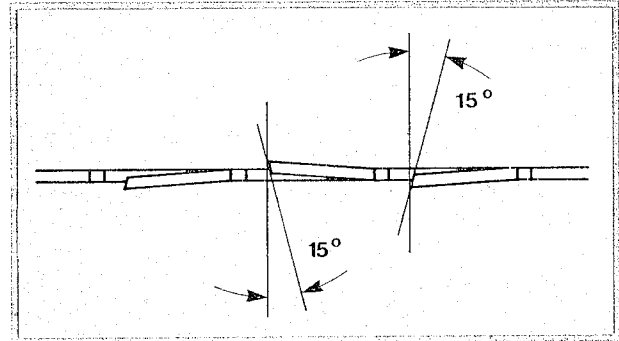
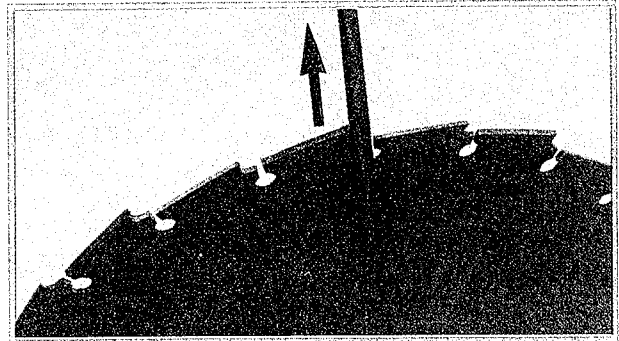

Chisel tooth circular saw blade

The chisel tooth circular saw blade can be resharpened with a 4.8 mm diameter round file (0811 411 8088). It is important to observe the filing angle (15°) and ensure that all the teeth have the same shape.

The blade can also be resharpened on an electric sharpener in the case of major or very uneven wear.

Your STIHL Service Shop will give you full details.

Rewind Starter

Replacing a broken starter rope

If the starter rope is broken there will be no tension on the rewind spring.

First remove the three mounting screws from the starter cover and take it off the crankcase.

Next, remove the screw (1) from the starter post together with the washer (2). The rope rotor (3) can now be pulled off the starter post – this must be done very carefully because the inner loop of the rewind spring (4) has to slip off of the rope rotor. If you feel any resistance, turn the rope rotor slightly counterclockwise while pulling it.

If the rope rotor (3) is not removed carefully, there is a risk of the spring loop catching on it and jumping out of its seat in the starter cover. If this happens, refit the rewind spring (4) in the starter cover as described under “Replacing a broken rewind spring”.

Remove remaining rope from the rotor (3), thread a new 3 mm dia. and 800 mm long (0.12 in dia. × 31.5 in long) starter rope through the rotor and secure it with a simple overhand knot. Pull the rope through so that the knot locates in the recess in the rotor (3). Push the other end of the rope through the hole in the starter cover (from the inside outward) and through the underside of the starter grip (5). Secure rope with a double knot.

Top: Mounting screws
Center: Removing screw from starter post
Bottom: Component parts in correct sequence

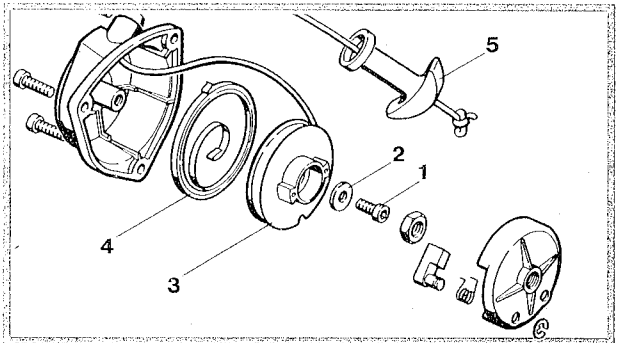
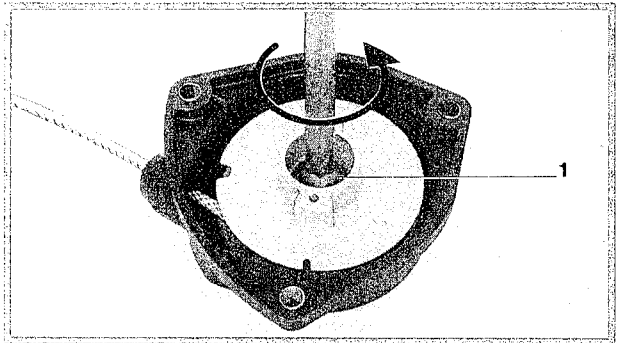
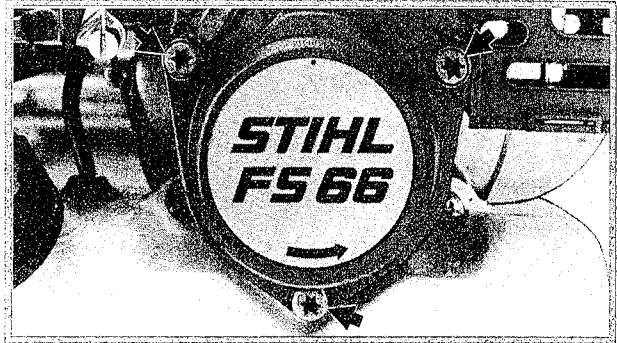

In the case of a new spring or one that has popped out of its seat it is necessary to check and correct the position of the inner spring loop before fitting the rope rotor (3). The position is correct when the loop is approx. 2 mm (0.08 in) away from the starter post.

Coat bore in rope rotor with non-resinous oil. Fit the rotor on the starter post so that the inner spring loop slides into the lug on the rotor. Position starter rope in notch on periphery of rotor at the same time. Check that spring loop has engaged by turning the rope rotor clockwise and letting it go – it must spring back.

Refit the washer (2) and screw (1) and tighten down securely. Finish off by tensioning the rewind spring.

Replacing a broken rewind spring

Remove the rope rotor (3) and use a pair of pliers to take the bits of the broken spring out of the starter cover.

The replacement spring comes ready for installation and is held in position by a wire retainer. It should be lubricated with a few drops of non-resinous oil before installation (e.g. STIHL low temperature lubricant 0781 417 1315).

Top: Rewind spring with inner loop correctly positioned
Bottom: Fitting the rope rotor

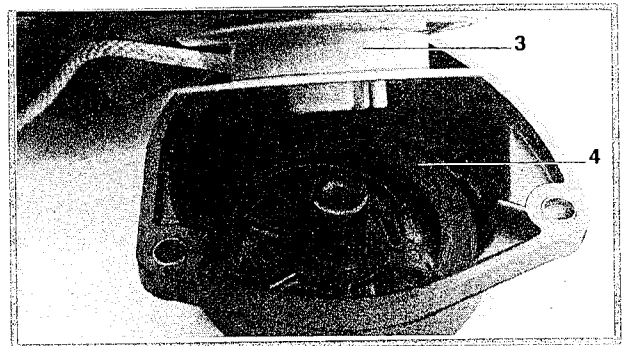
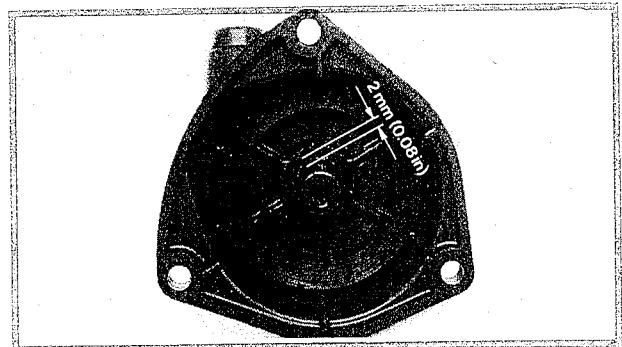

The wire retainer slides off as the rewind spring is positioned in the starter cover. The outer spring loop must be engaged on the lug in the starter cover. If the rewind spring pops out and uncoils during installation, it must be rewound – starting in the middle and working outward – and tensioned to a diameter of 50 mm (approx. 2"). Hold the rewind spring with pointed nose pliers about 10 mm (3/8") from the end of its outer loop and place it in the starter cover. Then refit the rope rotor (3).

Tensioning the rewind spring

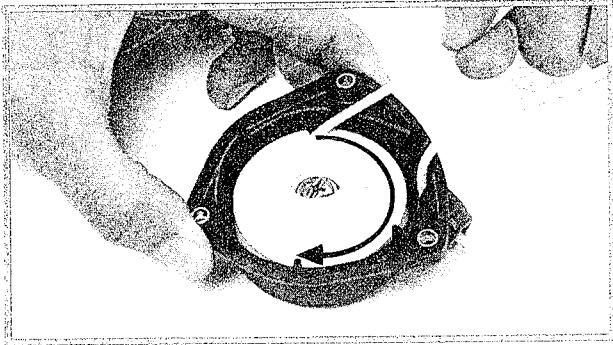

Tensioning the rewind spring

Pull the starter rope out as far as it will go. Make a loop in the rope between the rope rotor recess and the starter cover and use it to turn the rope rotor seven times clockwise. Hold the rope rotor steady, straighten out the twisted rope and pull it through the hole in the starter cover and hold firmly.

Release rope very slowly so that it can wind itself onto the rope rotor.

The rewind spring is correctly tensioned when the starter grip sits firmly on the starter cover without hanging to one side. When the starter rope is fully extended it must still be possible to rotate the rope rotor at least another half turn before maximum spring tension is reached. If this is not the case, hold the rope rotor firmly and take off one turn of the rope.

Do not overtension the rewind spring as this will cause it to break.

Maintenance Chart

		before starting work	after finishing work or daily	after each refueling stop	weekly	monthly	if faulty	if damaged	as required	see page:
Complete machine	Visual inspection (condition, leaks)	×		×						
	Clean		×							
Two-handed handlebar (throttle trigger, slide control)	Check operation	×		×						
Air filter	Clean	×								35
	Replace							×		35
Filter in fuel tank	Check					×				28
	Replace felt									28
Fuel tank	Clean					×				28
Carburetor	Check idle adjustment -- cutting tool must not turn	×		×						34
	Readjust idle								×	34
Spark plug	Readjust electrode gap						×			30
Cooling inlets	Clean		×							
Cylinder fins	Clean				×				×	
Spark arrestor screen	Inspect		×							
	Clean or replace								×	
All accessible screws and nuts (not adjusting screws)	Retighten								×	
	Visual inspection	×		×						37/38
Cutting tools	Replace							×	×	37/38
	Sharpen steel cutting tools								×	37/38
	Check tightness of cutting tool	×								22-27
Gearbox lubrication	Check	×								36
	Top up								×	36

The user of the brushcutter may carry out only the maintenance operations described in this manual. Other repair work should be performed only by an authorized STIHL service shop.

Warranty claims following a repair will be accepted only if the repair has been carried out by an authorized STIHL servicing dealer using original STIHL parts.

Specifications (FS 66 and FS 66 R)

Engine

Single cylinder two-stroke engine
Displacement: 19.6 cm³ (1.2 cu. in)
Bore: 31 mm (1.22 in)
Stroke: 26 mm (1.02 in)

Weight

FS 66: 5.9 kg (13 lb) without cutting tool
FS 66 R: 5.8 kg (12.8 lb) without cutting tool

Ignition System

Type: Electronic (contactless)
magneto ignition
Ignition timing: 1.3–1.7 mm
(0.05–0.07 in) B.T.D.C.
at 8,000 r.p.m.
Spark plug (suppressed): NGK BPMR 7 A or
Bosch WSR 6 F
Heat range 200
Electrode gap: 0.5 mm (0.02 in)
Spark plug thread: M 14x1,25; 9.5 mm (0.37 in) long

Fuel System

Carburetor: All position diaphragm
carburetor with integral
fuel pump
Air filter: Foam and felt elements
Fuel tank capacity: 0.4 l (0.84 US pt)
Fuel mixture: see chapter "Fuel"

Gearhead

Type: Helical toothed bevel gears
Ratio i: 1.33
Lubrication: STIHL gearhead grease
(0781 120 1117)

Special accessory for FS 66 (two-handed handlebar)

STIHL "Supercut 2" mowing head	4002 710 2140
Replacement nylon line (15.2 m/50 ft)	0000 930 2205
Replacement nylon line (90 m/300 ft)	0000 930 2214
STIHL "Polycut 1" mowing head	4111 710 2100*
Replacement blades (pack of 12)	4111 007 1001
STIHL "Polycut 2" mowing head	4002 710 2130**
STIHL "Polycut 2" mowing head	4002 710 2135*
Replacement blades (pack of 12)	4111 007 1001
STIHL "Polymatic 2" mowing head	4002 710 2120**
STIHL "Polymatic 2" mowing head	4002 710 2125
Replacement nylon line (15.2 m/50 ft)	0000 930 2205
Grass cutting blade 230	4112 713 3801
Brush knife 250	4112 713 4100
Circular saw blade 200 (Scratcher tooth)	4112 713 4201
Circular saw blade 200 (Chisel tooth)	4112 713 4203
Transport guard for steel cutting tools	4112 790 3902
Full harness	
Safety goggles	

Special accessory for FS 66 R (loop handle)

STIHL "Supercut 2" mowing head	4002 710 2140
Replacement nylon line (15.2 m/50 ft)	0000 930 2205
Replacement nylon line (90 m/300 ft)	0000 930 2214
STIHL "Polycut 1" mowing head	4111 710 2100*
Replacement blades (pack of 12)	4111 007 1001
STIHL "Polycut 2" mowing head	4002 710 2130**
STIHL "Polycut 2" mowing head	4002 710 2135*
Replacement blades (pack of 12)	4111 007 1001
STIHL "Polymatic 2" mowing head	4002 710 2120**
STIHL "Polymatic 2" mowing head	4002 710 2125
Replacement nylon line (15.2 m/50ft)	0000 930 2205
Grass cutting blade 230	4112 713 3801
Brush knife 250	4112 713 4100
Transport guard for steel cutting tools	4112 790 3902
Full harness	
Safety goggles	

Key to Symbols

1 = Always keep a 30 ft distance from persons while operating the brushcutter

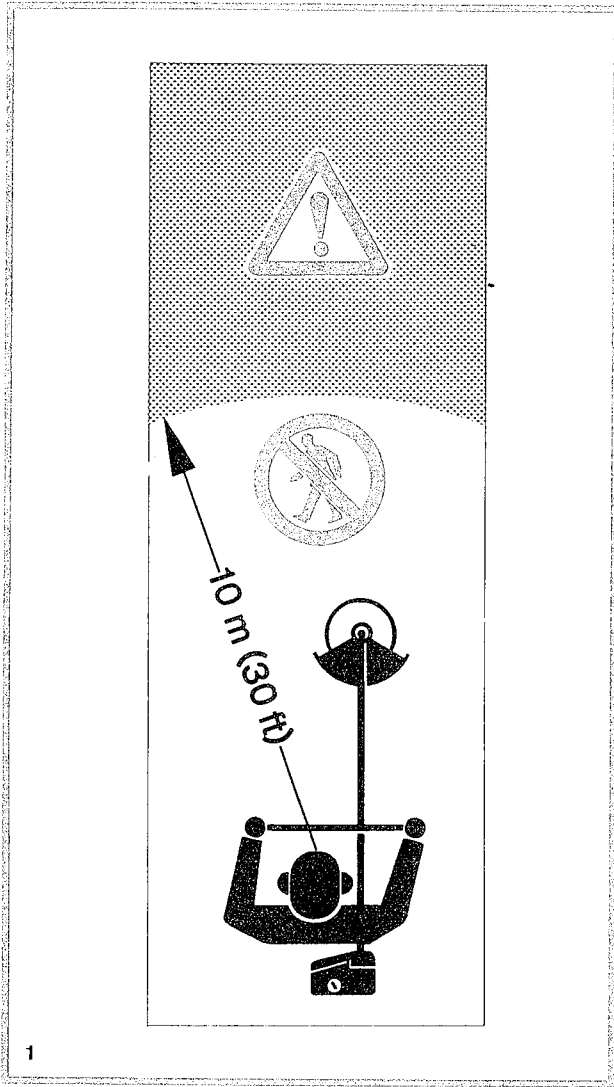

- 2 = Direction of rotation of cutting tool on stop
- 3 = Direction of rotation of cutting tool on standard metal deflector
- 4 = Direction of rotation of cutting tool on standard polymer deflector

